



ENGINEERING PHYSICS I & II

DIPLOMA COURSE IN ENGINEERING
FIRST AND SECOND SEMESTER

A Publication under
Government of Tamilnadu
Distribution of Free Textbook Programme
(NOT FOR SALE)

Untouchability is a sin
Untouchability is a crime
Untouchability is a inhuman

DIRECTORATE OF TECHNICAL EDUCATION
GOVERNMENT OF TAMILNADU

Padeepz App

Government of Tamilnadu
First Edition – 2015

THIRU. PRAVEEN KUMAR I.A.S

Principal Secretary / Commissioner of Technical Education
Directorate of Technical Education
Guindy, Chennai- 600025

Dr. K.SUNDARAMOORTHY, M.E., Phd.,

Additional Director of Technical Education (Polytechnics)
Directorate of Technical Education
Guindy, Chennai- 600025

Co-ordinator

Er. R.SORNAKUMAR M.E.,

Principal

Dr. Dharmambal Government
Polytechnic College for Women
Tharamani, Chennai—113

Convener

THIRU. K.SELVARAJAN M.Sc.,

HOD (UG) / Physics

Institute of Chemical Technology
Tharamani, Chennai—113

Reviewer

Dr.K.SIVAKUMAR, M.Sc., Phd.,

Professor of Physics and Dean, Regional office
Anna University, Madurai—7.

Authors

Dr.K.RAJESEKAR, M.Sc., Phd.,

Lecturer (UG)/ Physics

Government Polytechnic College
Nagercoil

THIRU S.NAGARAJAN, M.Sc.,

HOD(UG)/ Physics

Government Polytechnic College,
Purasaiwakkam, Chennai –12

THIRU.G.MOHANA SUNDARAM, M.Sc.,M.Phil.,M.Ed.,

HOD(UG)/Physics

Central Polytechnic College
Taramani, Chennai-113.

TMT.G.INDIRA, M.Sc.,M.Phil.,

Lecturer/Physics

Dr. Dharmambal Government
Polytechnic College for Women
Tharamani, Chennai—113

THIRU.N.SARAVANAN, M.Sc.,M.Phil,M.Ed.,

HOD(UG)/Physics

Meenakshi Krishnan Polytechnic College
Pammal, Chennai—75

This book has been prepared by the Directorate of Technical Education

This book has been printed on 60 G.S.M Paper

Through the Tamil Nadu Text book and Educational Services Corporation



FOREWORD

With the concept of Global Village after liberalisation and globalisation, our country India has become one of the most sought after destinations by many Multi National Companies for investment. The rapid growth in various fields of Engineering and Technology like Information technology, Automobile engineering, Infrastructure development, etc., demands much needed Human Resources.

The growth of various Industries demand qualified Technicians at different categories. The Diploma level education of Engineering and Technology offered by the various Polytechnic Colleges cater these Technician needs of the Industries.

Every Polytechnic college is offering diploma programmes in many fields of Engineering like Mechanical, Electrical, Civil, Electronics, Information Technology and special fields like Aeronautics, Chemical, Printing, Leather and textile technology etc.,

For all branches of study, the first year curriculum is common. The syllabus provides the necessary bridge between the school education and engineering education which the students pursue from their second year of study. For successful completion of engineering diploma with flying colours, a thorough knowledge of basics is very much essential.

The Content of this Engineering Physics I and Engineering Physics II provide necessary basic ideas and concepts in a bright manner. Real life applications and practical examples are included in this text wherever required. The experiments to be performed by the student in I and II semester Engineering Physics practical are also included in this text for the benefit of students.

The students should give due importance in understanding the various basic concepts with which only they can shine in their career, rather than reading them by heart.

AUTHORS

30013 ENGINEERING PHYSICS – I DETAILED SYLLABUS

UNIT I: SI UNITS AND STATICS

1.1 UNITS AND MEASUREMENTS:-

4Hrs

Unit-Definition-Fundamental Quantities-Definition-Seven fundamental quantities; their SI units and symbol for the units- Supplementary quantities-plane angle and solid angle; their SI units and symbol for the units Derived physical quantities. Dimensional formula for length, mass and time-derivation of dimensional formula for area, volume, density, velocity, momentum, acceleration, force, impulse, work or energy and power. Uses of Dimensional formula. Conventions followed in SI –Units Multiples & sub-multiples and prefixes of units.

1.2 STATICS:-

9 Hrs

Scalar and vector quantities–Definitions and examples–Concurrent forces and coplanar forces–Definition-Resolution of a vector into two perpendicular components -Resultant and equilibrant–Definitions-Parallelogram law of forces - statement - Expressions for magnitude and direction of the resultant of two forces acting at a point with an acute angle between them-Lami’s theorem-Statement and explanation-Experimental verification of parallelogram law of forces and Lami’s theorem. Simple problems based on expressions for magnitude and direction of resultant. Moment of a force-Clockwise and anti-clockwise moments-Principle of moments-Couple–Torque acting due to a Couple–Experimental determination of mass of the given body using principle of moments.

UNIT II: PROPERTIES OF MATTER

2.1 ELASTICITY:-

4 Hrs

Elastic and plastic bodies–Definition-stress, strain-Definitions–Hooke’s law – statement-three types of strain–Elastic and plastic limit–Young’s modulus, Bulk-modulus, Rigidity modulus and Poisson’s ratio–Definitions-Uniform and non-uniform bending of beams-Experimental determination of the Young’s modulus of the material of a beam by uniform bending method. Simple problems based on stress, strain and Young’s modulus.

2.2 VISCOSITY:-

5Hrs

Viscosity–Definition-Coefficient of viscosity-Definition, SI unit and dimensional formula -Stream line flow, turbulent flow-Explanation-Critical velocity–Definition-Reynolds number-Experimental comparison of coefficient of viscosity of two low viscous liquids –Terminal velocity–Definition-Experimental determination of coefficient of viscosity of a highly viscous liquid by Stokes method–Practical applications of viscosity.

2.3 SURFACE TENSION:-

4Hrs

Surface tension & angle of contact-Definitions-Expression for surface tension of a liquid by capillary rise method-Experimental determination of surface tension of water by capillary rise method–Practical applications of capillarity. Simple problems based on expression for surface tension.

UNIT III: DYNAMICS–I

3.1. STRAIGHTLINE MOTION:-

2 Hrs

Introduction-Newton’s Laws of motion-Fundamental Equations of motion for objects - horizontal motion-falling freely-thrown vertically upwards.

3.2 PROJECTILE MOTION:-

4Hrs.

Projectile motion, angle of projection, trajectory, maximum height, time of flight, and horizontal range—Definitions—Expressions for maximum height, time of flight and horizontal range—Condition for getting the maximum range of the projectile—Derivation of the equation to show that the trajectory of the projectile is a parabola. Simple problems based on expressions for maximum height, time of flight and horizontal range.

3.3 CIRCULAR MOTION:-

7Hrs.

Circular motion, angular velocity, period and frequency of revolutions—Definitions—Relation between linear velocity and angular velocity—Relation between angular velocity, period and frequency—Normal acceleration, centripetal force and centrifugal force—Definitions—Expressions for normal acceleration and centripetal force. Banking of curved paths—Angle of banking—Definition—Expression for the angle of banking of a curved path. $\{ \tan\theta = v^2 / (r g) \}$ Simple problems based on the expressions for centripetal force and angle of banking. Simple harmonic motion, amplitude, frequency and period - Definitions.

UNIT IV: DYNAMICS—II

4.1 ROTATIONAL MOTION OF RIGID BODIES:-

6Hrs

Rigid body—Definition—Moment of inertia of a particle about an axis, moment of inertia of a rigid body about an axis—expressions—Radius of gyration—Definition— Expression for the kinetic energy of a rotating rigid body about an axis—Angular momentum—Definition—Expression for the angular momentum of a rotating rigid body about an axis—Law of conservation of angular momentum—Examples.

4.2 GRAVITATION:-

3Hrs

Newton's laws of gravitation—Acceleration due to gravity on the surface of earth—Expression for variation of acceleration due to gravity with altitude

4.3 SATELLITES:-

4Hrs

Satellites—Natural and artificial—Escape velocity and orbital velocity—Definitions—Expression for escape velocity—Expression for orbital velocity—Uses of artificial satellites. Simple problems based on the expressions for escape velocity and orbital velocity.

UNIT V: SOUND AND MAGNETISM

5.1 SOUND:-

8Hrs

Wave motion—Introduction and definition—Audible range—Infrasonic—Ultrasonics—Progressive waves, longitudinal and transverse waves—Examples— Amplitude, wave length, period and frequency of a wave—Definitions—Relation between wave length, frequency and velocity of a wave—Stationary or standing waves. Vibrations—Free & forced vibrations and resonance—definitions and examples—Laws of transverse vibrations of a stretched string—Sonometer—Experimental determination of frequency of a tuning fork. Acoustics of buildings—Echo—Reverberation, reverberation time, Sabine's formula for reverberation time (no derivation) —Coefficient of absorption of sound energy—Noise pollution. Simple problems based on expression for frequency of vibration.

5.2 MAGNETISM:-

5Hrs

Pole strength —Definitions—Magnetic moment, intensity of magnetisation, magnetising field intensity, magnetic induction, permeability, hysteresis, saturation, retentivity and coercivity — Definitions - Method of drawing hysteresis loop of a specimen using a solenoid—Uses of Hysteresis loop simple problem based on intensity of magnetization.

Padeepz App

30024 ENGINEERING PHYSICS – II DETAILED SYLLABUS

UNIT I: HEAT

1.1 TRANSFER OF HEAT

4Hrs

Concept of Heat and Temperature - Centigrade, Fahrenheit and Kelvin scales of temperature measurement- Conduction, convection and radiation - Definitions and explanations- Coefficient of thermal conductivity- Definition and SI unit- good and poor conductors- Examples- Properties of thermal radiation.

1.2 KINETIC THEORY OF GASES

5Hrs

Postulates – Mean square velocity and Root Mean Square (RMS) velocity of molecules - Definitions and expressions – Expression for the pressure of a gas on the basis of postulates of kinetic theory of gases - Relation between pressure and kinetic energy, pressure and absolute temperature of the gas – Simple problems based on the expression for the pressure of a gas.

1.3 SPECIFIC HEAT CAPACITY

4Hrs

Specific heat capacity of a substance (solids and liquids) – Definition – Specific heat capacity of a gas at constant volume – Specific heat capacity of a gas at constant pressure – Ratio of specific heat capacities – Explanation for C_p is greater than C_v – Derivation of Mayer's relation – calculation of Universal gas constant R from the gas equation $PV = RT$. Simple problems based on Mayer's relation.

UNIT II: THERMODYNAMICS, LIQUEFACTION OF GASES - AND NON CONVENTIONAL ENERGY

2.1 THERMODYNAMICS

5Hrs

First law of thermodynamics – Statement – Isothermal and Adiabatic changes - Explanation – Equations for isothermal and adiabatic changes (No derivation) Simple problems based on equations $P_1V_1 = P_2V_2$ and $P_1V_1^\gamma = P_2V_2^\gamma$ Second law of thermodynamics – Clausius statement and Kelvin's statement – Working of Carnot's reversible engine with indicator diagram and its efficiency.

2.2 LIQUEFACTION OF GASES

5Hrs

Critical temperature, critical pressure and critical volume – Definitions – Principle used in cascade process – Cascade process of liquefaction of oxygen – Disadvantages of cascade process - Joule Thomson effect – Temperature of inversion – Liquefaction of air by Linde's process

2.3 NON – CONVENTIONAL ENERGY

3Hrs

Introduction – Non-renewable and Renewable (Alternate) energy sources – Examples – Solar energy, wind energy, – Advantages and disadvantages of renewable energy.

LIGHT AND REMOTE SENSING

3.1 OPTICS

5Hrs

Refraction – Laws of refraction – Refractive index of a medium – Definition – Spectrometer – Derivation of refractive index of glass prism using minimum deviation - Experimental determination of refractive index using spectrometer - Fiber optics – Introduction – Phenomenon of total internal reflection – problems using the refractive index .

Padeepz App

3.2 LASER

4Hrs

LASER – Characteristics of LASER – principle of LASER – Spontaneous emission – Stimulated emission – population inversion – Ruby laser-Construction and working- Uses of LASER.

3.3 REMOTE SENSING

4Hrs

Remote sensing – Introduction – Active and passive remote sensing – Explanation and examples – Components of remote sensing – Data acquisition, data analysis and reference data – RADAR – principle and working with block diagram.

UNIT IV: ELECTRICITY

4.1 ELECTRICAL CIRCUITS

4Hrs

Ohm's law – Laws of resistances – Resistivity, Conductivity, Super conductivity and Meissner effect- Definitions – Kirchhoff's current and voltage laws – Condition for balancing the Wheatstone's bridge .Simple problems based on expression for resistivity.

4.2 EFFECTS OF CURRENT

4Hrs

Joule's law of heating – Experimental determination of specific heat capacity of a liquid using Joule's calorimeter –Faraday's laws on electrolysis – Electro chemical equivalent (e.c.e) of an element – Definition – Experimental determination of e.c.e. of copper- Capacitance of a capacitor – Definition – ' farad '– Definition– expressions for effective capacitance when capacitors are connected in series and in parallel –Simple problems based on expressions for e.c.e., effective capacitance for series and parallel connections of capacitors.

4.3 MEASURING INSTRUMENTS

5Hrs

Expression for the force acting on a current carrying straight conductor placed in a uniform magnetic field – Fleming's Left Hand rule – Expression for the torque experienced by a rectangular current carrying coil placed inside a uniform magnetic field – Working of a moving coil galvanometer and its merits – Conversion of galvanometer into an Ammeter and Voltmeter. Simple problems based on conversion of galvanometer into ammeter and voltmeter.

UNIT V: ELECTRONICS

5.1 SEMI CONDUCTORS

4Hrs

Semi conductors – Energy bands in solids – Energy band diagram of good conductors, insulators and semi conductors– Concept of Fermi level - Intrinsic semiconductors - Concept of holes - Doping – Extrinsic semiconductors – P type and N type semiconductors.

5.2 DIODES AND TRANSISTORS

5Hrs

P-N junction diode – Forward bias and reverse bias –Rectification action of diode – Working of full wave rectifier using P N junction diodes -PNP and NPN transistors – Three different configurations –Advantages of common emitter configuration – Working of NPN transistor as an amplifier in common emitter configuration.

5.3 DIGITAL ELECTRONICS

4Hrs

Digital electronics – Introduction – Logic levels – Basic logic gates: OR, AND , NOT gates – Universal logic gates:NAND and NOR gates – Symbolic representation, Boolean expression and Truth table for all above logic gates – Integrated circuits– Levels of integration – SSI, MSI, LSI and VLSI-Advantages of ICs.

www.padeepz.net

ENGINEERING PHYSICS—I FIRST SEMESTER

UNIT	CONTENTS	PAGE NO.
UNIT I: SI UNITS AND STATICS		
1.1	UNITS AND MEASUREMENT	1
1.2	STATICS	6
UNIT II: PROPERTIES OF MATTER		
2.1	ELASTICITY	14
2.2	VISCOSITY	18
2.3	SURFACE TENSION	23
UNIT III: DYNAMICS—I		
3.1	STRAIGHT LINE MOTION	32
3.2	PROJECTILE MOTION	33
3.3	CIRCULAR MOTION	38
UNIT IV: DYNAMICS—II		
4.1	ROTATIONAL MOTION OF RIGID BODIES	49
4.2	GRAVITATION	54
4.3	SATELLITES	56
UNIT V: SOUND AND MAGNETISM		
5.1	SOUND	60
5.2	MAGNETISM	67
FIRST SEMESTER PRACTICAL-I		
1	MICROMETER (SCREW GAUGE)	75
2	VERNIER CALIPERS	78
3	CONCURRENT FORCES	81
4	COMPARISON OF VISCOSITIES OF LIQUIDS BY CAPILLARY FLOW METHOD	84
5	COEFFICIENT OF VISCOSITY OF HIGH VISCOUS LIQUID—STOKES' METHOD	86
6	SURFACE TENSION	89
7	SONAMETER	92
8	DEFLECTION MEGNETOMETER (TAN A—POSITION) COMPARISON OF MAGNETIC MOMENTS	95

UNIT	CONTENTS	PAGE NO.
UNIT I: HEAT		
1.1	TRANSFER OF HEAT	1
1.2	KINETIC THEORY OF GASES	4
1.3	SPECIFIC HEAT OF CAPACITY	8
UNIT II: THERMODYNAMICS, LIQUEFACTION OF GASES & NON CONVENTIONAL ENERGY		
2.1	THERMODYNAMICS	14
2.2	LIQUEFACTION OF GASES	18
2.3	NON CONVENTIONAL ENERGY	20
UNIT III: LIGHT AND REMOTE SENSING		
3.1	OPTICS	25
3.2	LASER	33
3.3	REMOTE SENSING	36
UNIT IV: ELECTRICITY		
4.1	ELECTRICAL CIRCUITS	42
4.2	EFFECTS OF CURRENT	47
4.3	MEASURING INSTRUMENTS	57
UNIT V: ELECTRONICS		
5.1	SEMICONDUCTORS	65
5.2	DIODES AND TRANSISTORS	69
5.3	DIGITAL ELECTRONICS	74
SECOND SEMESTER PRACTICAL		
1	REFRACTIVE INDEX	83
2	SOAR CEL	85
3	SPECTROMETER	87
4	OHM'S LAW	90
5	JOULE'S CALORIMETER	93
6	COPPER VOLTAMETER	96
7	CHARACTERISTICS OF P-N JUNCTION DIODE	98
8	LOGIC GATES	100

UNIT

1

SI UNITS AND STATICS

1.1 UNITS AND MEASUREMENT

Introduction:

The word physics comes from the Greek word meaning “nature”. Today physics is treated as the most fundamental branch of science and finds numerous applications of life. Physics deals with matter in relation to energy and the accurate measurement of the same. Thus physics is inherently a science of measurement. The fundamentals of physics form the basis for the study and the development of engineering and technology.

Measurement consists of the comparison of an unknown quantity with a known fixed quantity. The quantity used as the standard of measurement is called ‘unit’. For example, a vegetable vendor weighs the vegetables in terms of units like kilogram.

Fundamental physical quantities

Fundamental quantities are the quantities which cannot be expressed in terms of any other physical quantity.

(eg) length, mass and time.

Derived quantities

Quantities that can be expressed in terms of fundamental quantities are called derived quantities.

(eg) area, volume, density.

Unit

Unit of a physical quantity is defined as the accepted standard used for comparison of given physical quantity.

The unit in which the fundamental quantities are measured are called fundamental unit and the units used to measure derived quantities are called derived units.

SI Units

SI unit is the abbreviation for **System International de units** and is the modern form of metric system finally agreed upon at the eleventh International conference of weights and measures, 1960. This system of units is now being adopted throughout the world and will remain the primary system of units of measurement. SI system possesses features that make it logically superior to any other system.

There are seven fundamental units (base units) and two supplementary units.

SI system of units

Physical quantity	Unit	Symbol
Fundamental quantities		
1.Length	metre	m
2.Mass	kilogram	kg
3.Time	second	s
4.Electric current	ampere	A

5. Temperature	kelvin	K
6. Luminous Intensity	candela	cd
7. Amount of substance	mole	mol
Supplementary quantities		
1. Plane angle	radian	rad
2. Solid angle	steradian	sr

Derived quantities and their units

Sl.No	Physical quantity	Formula	Unit	Symbol
1	Area of the square	side \times side	metre ² or square metre	m ²
2	Volume of the cube	side \times side \times side	metre ³ or cubic metre	m ³
3	Density	Mass / volume	kilogram metre ⁻³	kgm ⁻³
4	Velocity	Displacement / time	metre second ⁻¹	ms ⁻¹
5	Acceleration	velocity/ time	metre second ⁻²	ms ⁻²
6	Momentum	mass \times velocity	Kilogram metre second ⁻¹	kgms ⁻¹
7	Force	mass \times acceleration	newton	N
8	Impulse	force \times time	newton second	Ns
9	Work (or) Energy	force \times displacement	newton metre or joule	J
10	Power	Work / time	joule second ⁻¹ or watt	W

Dimensions

The fundamental physical quantities namely length, mass and time are symbolically represented by the capital letters L, M and T respectively.

Dimensional formula is the formula in which the given physical quantity is expressed in terms of the fundamental quantities raised to suitable powers.

Dimensional formula for derived physical quantities.

1. Area of the square = side \times side

Applying dimensions

$$\text{Area of the square} = L \times L = L^2$$

$$\text{Dimensional formula for Area} = [L^2]$$

2. Volume of the cube = side \times side \times side

Applying dimensions

$$\text{Volume of the cube} = L \times L \times L = L^3$$

$$\text{Dimensional formula for Volume} = [L^3]$$

3. Density is the mass per unit Volume.

$$\text{Density} = \frac{\text{mass}}{\text{volume}}$$

Applying dimensions

$$\text{Density} = \frac{M}{L^3} = ML^{-3}$$

$$\text{Dimensional formula for Density} = [ML^{-3}]$$

4. Velocity is the rate of change of displacement

$$\text{Velocity} = \frac{\text{displacement}}{\text{time}}$$

Applying dimensions,

$$\text{Velocity} = \frac{L}{T} = LT^{-1}$$

Dimensional formula for Velocity = $[LT^{-1}]$

5. Acceleration is the rate of change of velocity

$$\begin{aligned} \text{Acceleration} &= \frac{\text{velocity}}{\text{time}} \\ &= \frac{\text{displacement}}{\text{time}} \times \frac{1}{\text{time}} \end{aligned}$$

Applying dimensions

$$= \frac{L}{T \times T} = \frac{L}{T^2} = LT^{-2}$$

Dimensional formula for Acceleration = $[LT^{-2}]$

6. Momentum is the product of mass and velocity.

Momentum = mass \times velocity

$$= \text{mass} \times \frac{\text{displacement}}{\text{time}}$$

Applying dimensions

$$\text{Momentum} = M \times \frac{L}{T} = MLT^{-1}$$

Dimensional formula for Momentum = $[MLT^{-1}]$

7. Force is the product of mass and acceleration.

Force = mass \times acceleration

$$\begin{aligned} &= \text{mass} \times \frac{\text{velocity}}{\text{time}} \\ &= \frac{\text{mass}}{\text{time}} \times \frac{\text{displacement}}{\text{time}} \end{aligned}$$

Applying dimensions,

$$\text{Force} = \frac{M}{T} \times \frac{L}{T} = MLT^{-2}$$

Dimensional formula for force = $[MLT^{-2}]$

8. Impulse is the product of force and time

Impulse = force \times time

$$= \text{mass} \times \text{acceleration} \times \text{time}$$

$$= \text{mass} \times \frac{\text{velocity}}{\text{time}} \times \text{time}$$

$$= \text{mass} \times \text{velocity}$$

$$= \text{mass} \times (\text{Displacement}/\text{time})$$

Applying dimensions,

$$\text{Impulse} = \frac{M \times L}{T} = MLT^{-1}$$

Dimensional formula for Impulse = $[MLT^{-1}]$

9. Work (or) Energy is the product of force and displacement

$$\begin{aligned} \text{Work or Energy} &= \text{force} \times \text{displacement} \\ &= \text{mass} \times \text{acceleration} \times \text{displacement} \\ &= \text{mass} \times \frac{\text{velocity}}{\text{time}} \times \text{displacement} \\ &= \frac{\text{mass}}{\text{time}} \times \frac{\text{displacement}}{\text{time}} \times \text{displacement} \end{aligned}$$

Applying dimensions

$$\text{Work or energy} = M \times \frac{L}{T} \times \frac{L}{T} = ML^2 T^{-2}$$

Dimensional formula for Work or Energy = $[ML^2 T^{-2}]$

10. Power is the rate of doing work.

$$\begin{aligned} \text{Power} &= \frac{\text{work}}{\text{time}} \\ &= \frac{\text{force} \times \text{displacement}}{\text{time}} \end{aligned}$$

Applying dimensions,

$$\text{Power} = MLT^{-2}, \frac{L}{T} = ML^2 T^{-3}$$

Dimensional formula for Power = $[ML^2 T^{-3}]$

Uses of Dimensional formula

- To check the dimensional correctness of a given equation.
- To convert a physical quantity from one system of unit to another.
- To establish a relationship between the physical quantity in an equation.

CONVENTIONS TO BE FOLLOWED IN SI UNITS

1. When we write a unit in full, the first letter should not be in capital letter.
(eg) metre and not as Metre
kilogram and not as Kilogram
2. The symbols of unit in the name of scientist should be in upper case (capital) letter
(eg) N for newton, J for joule.
3. Only the singular form of the unit is to be used.
(eg) km and not as kms
Kg and not as kgs
4. There should be no full stop at the end of the abbreviations.
(eg) mm and not as mm.
kg and not as kg.

5. When temperature is expressed in Kelvin, the degree sign is omitted.
(eg) 273K not as 273^oK
6. Only accepted symbols should be used.
(eg) ampere is represented as 'A' and not 'amp'
second is represented as 's' and not 'sec'
7. Use of the solidus or slash is to be avoided, but when used, not more than one solidus be employed.
(eg) J/k.mol or Jk.mol⁻¹ but not J/k/mol
J kg⁻¹ K⁻¹ but not J/kg/K
8. One letter space is always to be left between the number and the symbol of the unit.
(eg) 2.3 m and not as 2.3m
Kg m s⁻² and not kg ms⁻²
9. The numerical value of any physical quantity should be expressed as $p = a \times 10^m$. Here 'a' is a number between 1 and 10 and 'm' is the appropriate power of 10.
(eg) velocity of light $c = 2.997 \times 10^8 \text{ m s}^{-1}$

Multiples and Submultiples of units

In SI, some units are not of convenient size to measure certain quantities. Hence multiples and sub-multiples of the base units are used in measurements.

Multiplication factor	Prefix	Symbol
1 000 000 000 000 = 10 ¹²	Tera	T
1 000 000 000 = 10 ⁹	Giga	G
1 000 000 = 10 ⁶	Mega	M
1 000 = 10 ³	Kilo	K
100 = 10 ²	hecto*	h
10 = 10 ¹	deca*	da
0.1 = 10 ⁻¹	deci	d
0.01 = 10 ⁻²	centi*	c
0.001 = 10 ⁻³	milli	m
0.000 001 = 10 ⁻⁶	micro	μ
0.000 000 001 = 10 ⁻⁹	nano	n
0.000 000 000 001 = 10 ⁻¹²	pico	p
0.000 000 000 000 001 = 10 ⁻¹⁵	femto	f
0.000 000 000 000 000 001 = 10 ⁻¹⁸	atto	a

*These are not preferred ones. They are used where the other prefixes are inconvenient

Padeepz App

1.2 STATICS

Statics is the part of mechanics which deals with forces acting on bodies at rest. The weight of the body, the tension of a string, the load and the reaction are the different names of forces that are used in statics.

Any force can be represented in magnitude and direction by a straight line with an arrow head. The beginning of the line represents the point of application of the force. The arrow head represents the direction of the force. The magnitude of the force is given by the length of the line drawn to scale.

Scalar and Vector quantities

Physical quantities which have magnitude only are called scalar quantities.

(e.g) Mass, Volume, Speed

Physical quantities which have both magnitude and direction are called vector quantities.

(e.g) Velocity, Momentum, Force

Concurrent forces

Two or more than two forces acting at a point are called concurrent forces.

Coplanar forces

Two or more than two forces lie on same plane are called coplanar forces.

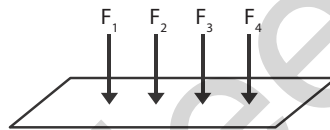

Resultant

Resultant is that single force which produces the same effect as that produced by two or more forces acting on the body.

Equilibrant

Equilibrant is the single force which acting along with the other forces keeps the body in equilibrium.

Resolution of a vector into two perpendicular components

The process of splitting up a vector (force) into two perpendicular component parts is known as resolution of a vector. As the two component forces are mutually perpendicular, they are called rectangular components.

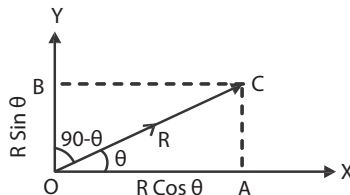

Let a force R act at a point O at an angle θ with x -axis. This force can be resolved into two rectangular components along x and y axis. Two lines CA and CB are drawn perpendicular to x and y axis as shown in the figure.

In the right angled triangle OAC ,

$$\cos \theta = \frac{OA}{OC}$$

$$\begin{aligned} OA &= OC \cos \theta \\ &= R \cos \theta \end{aligned}$$

Therefore the horizontal component of the force R is $R \cos\theta$. In the right angled triangle OBC,

$$\cos(90 - \theta) = \frac{OB}{OC}$$

$$\sin \theta = \frac{OB}{OC}$$

$$OB = OC \sin \theta = R \sin \theta$$

The vertical component of the force R is $R \sin \theta$.

Parallelogram law of forces

If two forces acting at a point are represented in magnitude and direction by the two adjacent sides of a parallelogram drawn from that point, their resultant is given in magnitude and direction by the diagonal of the parallelogram drawn through that point.

Expressions for the magnitude and direction of the resultant of two forces acting at a point, with an acute angle between them.

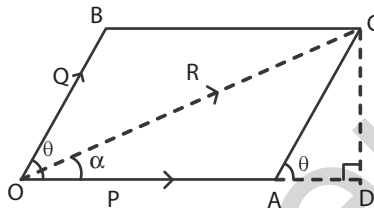

Consider two forces P and Q acting at a point O with an angle θ between them as shown in the figure. The forces P and Q are represented in magnitude and direction by the sides OA and OB of a parallelogram OACB. The diagonal OC gives the resultant of two forces P and Q in magnitude and direction. From C draw a perpendicular to meet OA extended at D.

In the right angled triangle OCD

$$\begin{aligned} OC^2 &= OD^2 + CD^2 \\ &= (OA + AD)^2 + CD^2 \\ OC^2 &= OA^2 + AD^2 + 2OA \cdot AD + CD^2 \end{aligned} \quad \dots(1)$$

In the right angled triangle ACD

$$\begin{aligned} \cos \theta &= \frac{AD}{AC} = \frac{AD}{Q} \\ AD &= Q \cos \theta \\ \sin \theta &= \frac{CD}{AC} = \frac{CD}{Q} \\ CD &= Q \sin \theta. \end{aligned}$$

Substituting AD and CD values in eqn.(1)

$$\begin{aligned} R^2 &= P^2 + Q^2 \cos^2 \theta + 2PQ \cos \theta + Q^2 \sin^2 \theta \\ R^2 &= P^2 + Q^2 (\cos^2 \theta + \sin^2 \theta) + 2PQ \cos \theta \\ R^2 &= P^2 + Q^2 + 2PQ \cos \theta \quad \text{where } \cos^2 \theta + \sin^2 \theta = 1 \end{aligned}$$

$$\text{Resultant, } R = \sqrt{P^2 + Q^2 + 2PQ \cos \theta}$$

This is the expression for the magnitude of the resultant.

Let α be the angle between the resultant R and the force P.

$$\tan \alpha = \frac{CD}{OD} = \frac{CD}{OA + AD} = \frac{Q \sin \theta}{P + Q \cos \theta}$$

$$\text{Direction, } \alpha = \tan^{-1} \left[\frac{(Q \sin \theta)}{(P + Q \cos \theta)} \right]$$

In the right angled triangle COD,

This is the expression for the direction of the resultant.

Lami's theorem

If three forces acting at a point are in equilibrium, then each force is directly proportional to the sine of the angle between the other two forces.

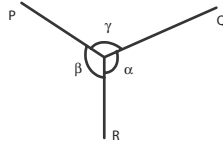

Let P, Q and R be three forces acting at a point O. Under the action of three forces, the point is at rest. Let α , β and γ be the angles opposite to the forces P, Q and R respectively.

By Lami's theorem

$$P \propto \sin \alpha \Rightarrow P = K \sin \alpha \Rightarrow \frac{P}{\sin \alpha} = K$$

$$Q \propto \sin \beta \Rightarrow Q = K \sin \beta \Rightarrow \frac{Q}{\sin \beta} = K$$

$$R \propto \sin \gamma \Rightarrow R = K \sin \gamma \Rightarrow \frac{R}{\sin \gamma} = K$$

$$\frac{P}{\sin \alpha} = \frac{Q}{\sin \beta} = \frac{R}{\sin \gamma} = \text{constant}$$

Experimental verification of parallelogram law of forces

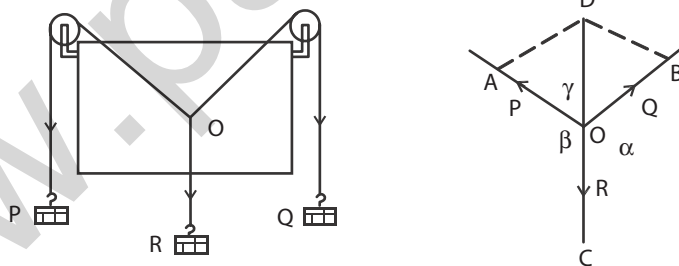

A drawing board is fixed vertically on the wall. Two frictionless pulleys are fixed at the top corners of the drawing board. A light and inextensible string is passed over these pulleys. Another short string is tied to the first string at O. Weight hangers P, Q and R are tied at the ends of the strings as shown in the figure. The weights P, Q and R are adjusted suitably such that the point O is at rest.

A white paper is held just behind the string without touching them. The point O and the directions of the strings are marked on the paper. Then the paper is removed from the board. With suitable scale the points A, B and C are marked. OA, OB and OC represent the forces P, Q and R respectively.

The parallelogram OADB is drawn. Then the diagonal OD is drawn. The length of the diagonal OD and $\angle COD$ are measured and tabulated.

Sl. No	P	Q	R	OA	OB	OC	OD	$\angle COD$

The experiment is repeated for different values of P, Q and R. It is found that $OC = OD$ and $\angle COD = 180^\circ$. Thus the parallelogram law of forces is verified experimentally.

Experimental verification of Lami's theorem

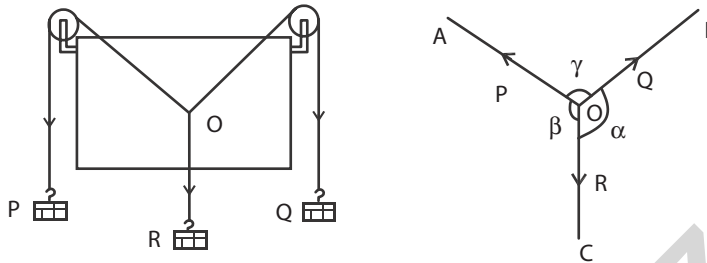

A drawing board is fixed vertically on the wall. Two frictionless pulleys are fixed at the top corners of the drawing board. A light and inextensible string is passed over these pulleys. Another short string is tied to the first string at O. Weight hangers P, Q and R are tied at the ends of the strings as shown in the figure. The weights P, Q and R are adjusted suitably such that the point O is at rest.

A white paper is held just behind the string without touching them. The point O and the directions of the forces P, Q and R are marked on the paper. Then the paper is removed from the board. Let α , β and γ are the angles opposite to the forces P, Q and R respectively. The angles are measured with the help of protractor and tabulated.

Sl. No	P	Q	R	α	β	γ	$\frac{P}{\sin \alpha}$	$\frac{Q}{\sin \beta}$	$\frac{R}{\sin \gamma}$

The experiment is repeated for different values of P, Q and R. The ratios $(P / \sin \alpha)$, $(Q / \sin \beta)$ and $(R / \sin \gamma)$ are calculated. For each set of readings, the ratios are found to be equal. Thus Lami's theorem is verified experimentally.

Moment of a force

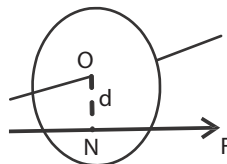

Consider a body which is fixed at a point, about which it can rotate freely. Let a force F is acting on the body. The effect of the force is to rotate the body about the fixed point, unless the line of action of the force passes through that fixed point O. This rotating tendency or the turning effect of the force about that point is called moment of force i.e. the turning effect of the force acting on a body about an axis or point is called moment of force.

It is common experience that in opening or closing a door, the force we apply rotates the door about its hinges. This rotating effect is known as the moment of force.

Moment of force is also equal to the product of the magnitude of the force and the perpendicular distance of the line of action of the force from the axis of rotation.

Moment of force about the point O = Force \times perpendicular distance of the force from the point O
 $= F \times ON$

The unit of moment of force is N m and the dimensional formula is ML^2T^{-2} .

Clockwise and anti-clockwise moments

If the moment of a force turns or rotates the body in clockwise direction, then it is called as clockwise moment.

If the moment of a force turns or rotates the body in anti-clockwise direction, then it is called anti-clockwise moment.

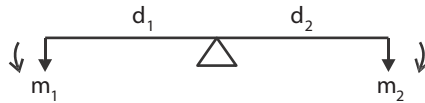

Clockwise moment = $m_2 \times d_2$

Anti-clockwise moment = $m_1 \times d_1$

Principle of moments

The principle of moment states that if a body is in equilibrium under the action of a number of parallel forces, the sum of the clockwise moments about any point must be equal to the sum of anti-clockwise moments about the same point.

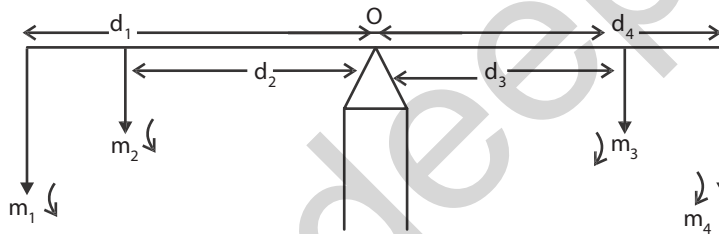

According to the principle of moments,

Sum of anti-clockwise moments = sum of clockwise moments

From figure,

$$m_1 d_1 + m_2 d_2 = m_3 d_3 + m_4 d_4.$$

Couple:

Two equal and opposite parallel forces acting at different points in a body constitute a couple. A body acted upon by the couple will rotate the body in clockwise direction or anti-clockwise direction.

Steering wheel and pedals of bicycles are the examples for couple, where the two forces are equal but acting in opposite direction.

Torque acting due to couple (or) Moment of couple

Torque is calculated by the product of either of forces forming the couple and the arm of the couple.

i.e.) Torque = one of the force \times perpendicular distance between the forces.

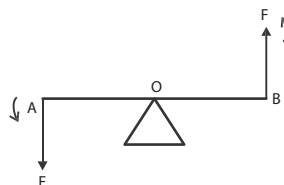

Consider two equal forces F and F acting on the arm AB . Let O be the mid point of the arm. The forces F and F are acting in opposite direction as shown in the figure, they constitute a couple. Then

Moment of couple or torque = $F \times AB$.

If the forces acting on the body have the same line of action then the moment becomes zero. The torque is maximum when the forces are at right angles to the arm i.e.) $\theta=90^\circ$.

Determination of mass of the given body using principle of moments.

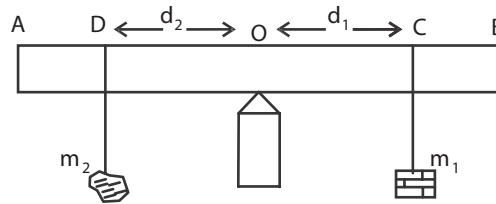

A meter scale AB is supported on a knife edge at its centre such that it remains in equilibrium state. Let O be the centre of the scale. On the right side suspend the weight hanger of mass m_1 and on the left side suspend the given body m_2 whose mass is to be calculated. Adjust the positions of m_1 and m_2 until the scale comes to the exact equilibrium position. Let d_1 (OC) and d_2 (OD) be the distances of m_1 and m_2 .

According to the principle of moments

$$m_2 \times d_2 = m_1 \times d_1$$

The mass of the given body $m_2 = (m_1 \times d_1) / d_2$

By changing the values of m_1 , the experiment is repeated and the readings are tabulated.

Sl.No	m_1 kg	d_1 m	d_2 m	$m_2 = (m_1 \times d_1) / d_2$ kg

Mean =

The average value of the last column gives the mass of the body.

WORKED EXAMPLES

1. Find the magnitude and direction of the two forces 20N and 25N acting at an angle 60° to each other.

Given:

$P = 20N$ $Q = 25N$ $\theta = 60^\circ$

Resultant $R = \sqrt{P^2 + Q^2 + 2PQ \cos \theta}$

$= \sqrt{20^2 + 25^2 + 2 \times 20 \times 25 \cos 60}$

$= \sqrt{1525}$

$R = 39.05N$

Direction $\alpha = \tan^{-1} \left[\frac{(Q \sin \theta)}{(P + Q \cos \theta)} \right]$

$\alpha = \tan^{-1} \left[\frac{25 \times \sin 60^\circ}{20 + 25 \cos 60^\circ} \right]$

$\alpha = \tan^{-1} (0.6661)$

$\alpha = 33^\circ 40'$

2. Find the magnitude and direction of the resultant of two forces 30N and 40N acting at right angles to each other.

Given

$$P = 30\text{N}$$

$$Q = 40\text{N} \quad \theta = 90^\circ$$

$$\begin{aligned} \text{Resultant } R &= \sqrt{P^2 + Q^2 + 2PQ \cos \theta} \\ &= \sqrt{30^2 + 40^2 + 2 \times 30 \times 40 \times \cos 90} \\ &= \sqrt{2500} \\ R &= 50\text{N} \end{aligned}$$

$$\begin{aligned} \text{Direction } \alpha &= \tan^{-1} \left[\frac{(40 \times \sin 90)}{(30 + 40 \cos 90)} \right] \\ &= \tan^{-1} (1.333) \\ \alpha &= 53^\circ 7' \end{aligned}$$

3. If the resultant of two equal force is $\sqrt{3}$ times a single force, find the angle between the forces.

Given

Two forces are equal

$$P = Q = P$$

$$R = \sqrt{3} P$$

$$R^2 = P^2 + Q^2 + 2PQ \cos \theta$$

$$(3P)^2 = P^2 + P^2 + 2.P.P.\cos \theta$$

$$3P^2 - 2P^2 = 2P^2 \cos \theta$$

$$P^2 = 2P^2 \cos \theta$$

$$\cos \theta = \frac{1}{2}$$

$$\therefore \theta = 60^\circ$$

Angle between the forces is 60°

4. If the resultant of two equal forces inclined to each other at 60° is $8\sqrt{3}$ N, find the component forces.

Given

Two forces are equal.

$$P = Q = P$$

$$R = 8\sqrt{3} \text{ N}$$

$$\theta = 60^\circ$$

$$R^2 = P^2 + Q^2 + 2PQ \cos \theta$$

$$(8\sqrt{3})^2 = P^2 + P^2 + 2.P.P.\cos 60^\circ$$

$$192 = 2P^2 + 2P^2 \cdot \frac{1}{2}$$

$$192 = 3P^2$$

$$64 = P^2$$

$$P = 8\text{N}$$

Component force is 8N

5. The sum of two forces is 8N and the magnitude of the resultant is at right angles to the smaller force 4N. Find the forces and the inclination between them.

Given

Sum of the two forces = 8 N

Resultant of 2 forces = 4 N

Let the smaller force be P

Larger force Q = (8-P)

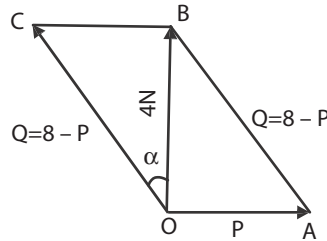

In the right angled triangle OAB,

$$AB^2 = OA^2 + OB^2$$

$$(8 - P)^2 = P^2 + 4^2$$

$$64 - 16P + P^2 = P^2 + 16$$

$$16P = 48$$

$$P = 3\text{N}$$

Therefore the larger force Q = 8-3

$$Q = 5\text{N}$$

In triangle OCB,

$$\tan \alpha = \frac{BC}{OB} = \frac{P}{4} = \frac{3}{4} = 0.75$$

$$\alpha = \tan^{-1}(0.75)$$

$$\alpha = 36^\circ 52'$$

Angle between the forces P and Q

$$90 + \alpha = 90 + 36^\circ 52'$$

$$= 126^\circ 52'$$

QUESTIONS

Part A and Part B

1. What are the fundamental quantities?
2. What are the derived quantities?
3. What are the supplementary quantities and their SI units?
4. What are the units for momentum , force, impulse and work?
5. What are the units for energy and power, acceleration and density?
6. What are the dimensional formula for impulse and momentum.
7. What are the dimensional formula for work or energy.
8. What are the dimensional formula for power and force
9. Define scalar quantity with example

10. Define vector quantity with example.
11. What is resultant?
12. What is equilibrant?
13. Write the parallelogram law of forces.
14. Write the Lami's theorem.
15. Write any two conventions followed in SI unit.
16. Define concurrent forces.
17. Define coplanar forces.
18. Define moment of a force.
19. Write the principle of moments.
20. Define couple.
21. Define moment of a couple.
22. Define clockwise moment and anticlockwise moment.
23. Write any three uses of dimensional formula
24. Derive dimensional formula for impulse, work and power.
25. Write any three the rules and conventions followed while writing SI.
26. Explain how a vector can be resolved into two rectangular components.
27. Find the magnitude of the two forces 3 N and 5 N acting at right angle to each other

Part- C

1. Give the rules and conventions followed while writing SI units
2. Derive expressions for the magnitude and direction of the resultant of two forces acting at a point with an acute angle between them.
3. Describe an experiment to verify the parallelogram law of forces.
4. Describe an experiment to verify Lami's theorem.
5. Describe an experiment to determine the mass of the given body using principle of moments.

Exercise Problems

1. Find the magnitude and direction of the resultant of two forces of 5N and 3N at an angle of 60° .
(Ans: $R = 7N$, $\alpha = 21^\circ 47'$)
2. Two forces of magnitude 4N and 2.5N acting at a point inclined at an angle of 40° to each other. Find their resultant.
(Ans: $R = 6.149N$, $\alpha = 15^\circ 8'$)
3. Find the resultant of two forces 3N and 4N acting on a particle in direction inclined at 30° .
(Ans: $R = 6.767N$, $\alpha = 17^\circ 19'$)
4. Two forces of magnitude 4N and 3N respectively, act on a particle at right angles to each other. Find the magnitude and direction of the resultant of two forces.
(Ans: $R = 5N$, $\alpha = 36^\circ 52'$)

5. If the resultant of two equal forces is 2 times the single force, find the angle between them.
(Ans: $\theta = 90^\circ$)
6. If the resultant of two equal forces inclined to each other at 60° is 8.660 N, find the component force.
(Ans: 5N)
7. If the resultant of two forces 6N and 8N is 12N, find the angle between them.
(Ans: $62^\circ 43'$)
8. The sum of two forces inclined to each other at an angle is 18N and their resultant which is perpendicular to the smaller force is 12N. Find the forces and angle between them.
(Ans: $P = 5N, Q = 13N, \theta = 112^\circ 36'$)

UNIT

2

PROPERTIES OF MATTER

2.1 ELASTICITY

Introduction:

When an external force is applied on a body, which is not free to move, the shape and size of the body change. The force applied is called deforming force. When the deforming forces are removed, the body tends to regain its original shape and size due to a force developed within the body. The force developed within the body, which is equal and opposite to deforming force is called restoring force.

Bodies, which completely regain their original size and shape after the removal of the deforming force, are called elastic bodies. Bodies which change the shape and size on the application of force and which do not regain their original condition on removal of the deforming forces are said to be plastic bodies. Bodies which do not change their shape and size on application of force are called rigid bodies.

The property by virtue of which a body tends to regain its original shape and size after removal of the deforming force is known as elasticity.

Stress :

When an external force is acting on an elastic body, it causes deformation (change in shape or in size or both). At the same time, due to elastic property, a force is developed within the material, which is equal and opposite to the applied force, to bring the body to its original shape and size. This force is 'restoring force'.

$$\text{Stress} = \frac{\text{Force}}{\text{Area}} = \frac{F}{A}$$

The stress is defined as the restoring force acting on unit area.

Since the applied force and the restoring force are equal in magnitude, the 'stress' is measured as the applied force acting per unit area.

The unit for stress is newton metre⁻² with symbol N m⁻² or 'pascal' with symbol 'Pa'.

When the applied force tends to compress the body, the stress is compressive. When it tends to increase the length in the direction of the force, it is tensile and when it acts parallel to the surface of a body, the stress is tangential stress.

Hooke's law:

Within the elastic limits, the strain produced in a body is directly proportional to the stress which causes it.

i.e., strain \propto stress

or stress \propto strain

$\therefore \frac{\text{stress}}{\text{strain}} = \text{a constant}$

This constant is called 'modulus of elasticity'.

Types of strains:

Strain: Change in dimensions to original dimensions is known as Strain.

(1) Linear Strain:

When a wire or bar is subjected to two equal and opposite forces, namely pulls, at its ends, there is an increase in the length. If the forces are tensile, the body is elongated. If the forces are compressive, the length is shortened in the direction of the forces. This is called the 'linear strain'.

The linear strain is defined as the ratio of change in length to the original length. If the change (increase or decrease) in length is 'l' in a wire or bar of original length L,

As the linear strain is ratio of lengths, it has no unit.

$$\text{linear strain} = \frac{\text{Change in length}}{\text{original length}} = \frac{l}{L}$$

(2) Bulk (or) Volume Strain:

When a force is applied uniformly and normally to the entire surface of the body, there is a change in volume of the body, without any change in its shape. This strain is called 'bulk or volume strain'.

Volume strain is defined as the ratio of change in volume to the original volume. It has also no unit. If 'v' is the change in volume produced in a body of original volume 'V',

$$\text{bulk or volume strain} = \frac{\text{Change in volume}}{\text{original volume}} = \frac{v}{V}$$

(3) Shearing (or) Rigidity strain:

When a force is applied parallel to one face of a body, the opposite side being fixed, there is a change in shape but not in size of the body. This strain is called the shearing strain.

Solids alone can have a shearing strain. It is measured by the angle of the shear 'θ' in radian.

Three moduli of elasticity

There are three types of moduli depending upon the three kinds of strain.

(a) Young's modulus (E):

It is defined as the ratio of linear stress to linear strain.

Let a wire of initial length L and cross-sectional area 'A', undergo an extension l, when a stretching force 'F', is applied in the direction of its length.

The modulus of elasticity, in this case, is called Young's modulus and is given by

$$\text{i.e., Young's modulus (E)} = \frac{\text{Linear stress}}{\text{Linear strain}}$$

$$\text{Then, longitudinal or linear stress} = \frac{F}{A}$$

$$\text{and longitudinal strain} = \frac{l}{L}$$

$$E = \frac{\text{Linear stress}}{\text{Linear strain}} = \frac{F/A}{l/L} = \frac{FL}{Al}$$

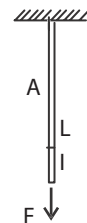

The unit for Young's modulus is newton metre⁻² with symbol N m⁻². The single term unit which is widely used for Young's modulus is 'pascal' with symbol 'Pa'.

(b) Bulk (or) Volume modulus (k):

It is defined as the ratio of bulk stress to bulk strain.

When a body is subjected to a uniform compressive force, its volume decreases and the strain produced is a bulk or volume strain.

If 'v' is the change in volume and V is the original volume, then

If F is the total compressive force acting on a total area A, then bulk stress = $F/A = P$

$$\text{Bulk modulus (k)} = \frac{\text{Bulk stress}}{\text{Bulk strain}}$$

If P is the stress applied i.e. (force/unit area) then,

$$\text{bulk strain} = \frac{v}{V}$$

$$\text{bulk modulus } k = \frac{P}{v/V} = \frac{P \cdot V}{v}$$

The unit for bulk modulus is 'newton metre⁻²' with symbol N m⁻². The single term unit which is widely used for bulk modulus is 'pascal' with symbol 'Pa'.

(c) Shearing (or) Rigidity modulus 'n':

The ratio of the shearing stress applied to the body to the shearing strain produced is called the rigidity modulus and denoted by the letter 'n'.

If T is the tangential force/unit area and if θ is the angle of shear measured in radian, then

$$\text{rigidity modulus } n = \frac{T}{\theta} = \frac{F}{A\theta}$$

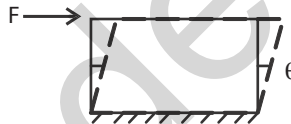

The unit for rigidity modulus is 'newton metre⁻² radian⁻¹' with symbol N m⁻² rad⁻¹. The other unit which is widely used for rigidity modulus is 'pascal radian⁻¹' with symbol 'Pa rad⁻¹'.

Poisson's ratio: σ

When a tensile stress is applied to a wire, the wire undergoes not only an extension of length in the direction of the force but also a contraction in its thickness. The ratio of decrease in thickness to the original thickness in lateral direction is known as lateral contraction.

The ratio of lateral contraction to linear elongation is called Poisson's ratio.

$$\text{Poisson 's ratio } \sigma = \frac{\text{Lateral contraction}}{\text{Linear elongation}}$$

Bending of beams:

A beam is a body having uniform cross section, the length of which is very large compared to its thickness. When such a beam is fixed at one end and loaded at the other end, it is called a cantilever.

A beam is supported symmetrically on two knife edges A and B at the same level. It is loaded symmetrically with two equal weights W, W, beyond the knife edges, at C and D, so that AC=BD=a. Now the beam is elevated at the centre. This type of bending is called uniform bending of beam.

A beam is supported symmetrically on two knife edges A and B near its ends in a horizontal level. A weight hanger W is suspended by means of a loop of thread from a point which is exactly midway between the two knife edges. Now the beam is depressed at the centre. This type of bending is called non-uniform bending of beam.

Experiment to determine the Young's modulus of the material of a beam by uniform bending method:

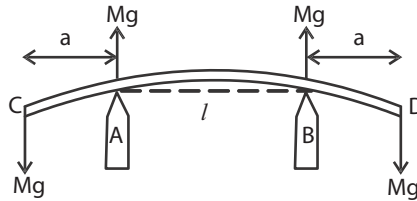

The given bar is supported symmetrically on two knife edges in a horizontal level, so that a quarter of the bar projects beyond each knife edge. Two weight hangers are suspended from two loops of string tightly attached at distances about 5 cm from each end so that their distances from the knife edges are equal. A pin is fixed vertically at the midpoint of the bar. A traveling microscope is focused on the pin such that the horizontal crosswire coincides with the tip of the pin. The reading in the vertical scale of the microscope is noted. Weights are added in steps of M kg and the corresponding readings of the image of the pin in the microscope are noted. Similarly readings are taken while unloading and tabulated.

The mean elevation y is found for a load of M kg. The distance 'l' between the knife edges is measured. The distance 'a' between the point of suspension of the weight and the nearest knife edge is also measured. The breadth 'b' of the bar found accurately with the vernier calipers and its thickness d is found with a screw gauge. Young's modulus is calculated using the formula.

$$E = \frac{3Mgal^2}{2bd^3y} \text{ Nm}^{-2}$$

Load in Kg	Microscope reading			Elevation y For M kg
	Load increasing	Load decreasing	Mean	
x				
x + M				
x+2M				
x+3M				

Worked examples

1. A load of 5 kg is attached to the free end of a wire of length 2 m and diameter 0.6 mm. If the extension of the wire is 0.2 mm, calculate the Young's modulus of the material of the wire. ($g = 9.8 \text{ ms}^{-2}$)

Length of the wire $L = 2 \text{ m}$

Extension of the wire $I = 0.2 \text{ mm} = 0.2 \times 10^{-3} \text{ m}$

Force acting of the wire $F = 5\text{kgf} = 5 \times 9.8 \text{ N}$

Diameter of the wire $d = 0.6 \text{ mm} = 0.6 \times 10^{-3} \text{ m}$

Radius of the wire $= 0.3 \times 10^{-3} \text{ m}$

Area of cross section of the wire $a = \pi r^2 = \pi (3 \times 10^{-4})^2 \text{ m}^2$

Young's modulus = Linear stress/Linear strain

$$\text{Linear stress } \frac{F}{A} = \frac{5 \times 9.8}{\pi (3 \times 10^{-4})^2} = 1.734 \times 10^8 \text{ Nm}^{-2}$$

$$\begin{aligned}\text{Linear strain } \frac{l}{L} &= \frac{2 \times 10^{-4}}{2} = 1 \times 10^{-4} \\ &= \frac{1.734 \times 10^8}{1 \times 10^{-4}} = 1.734 \times 10^{12} \text{ Nm}^{-2}\end{aligned}$$

2. A copper wire of 3 m length and 1 mm diameter is subjected to a tension of 5 kg wt. Calculate the elongation produced in the wire, if Young's modulus of elasticity of copper is 120 G Pa.

$$\begin{aligned}\text{Young's modulus } E &= \frac{F/A}{l/L} \\ E &= \frac{FL}{Al} \\ \text{Elongation produced } l &= \frac{FL}{AE} \\ &= \frac{MgL}{\pi r^2 \times E} = \frac{5 \times 9.8 \times 3}{3.14 (0.5 \times 10^{-3})^2 \times 120 \times 10^9} = 1.562 \times 10^{-3} \text{ m}\end{aligned}$$

3. What is the force required to a steel wire to double its length when its area of cross-section is one sq. cm and Young's modulus is 200 G Pa. As the length of the wire is doubled, the change in length is equal to its original length.

$$\begin{aligned}\text{The young's modulus } E &= \frac{FL}{Al} \\ F &= \frac{EAl}{L} \\ &= \frac{EAL}{L}\end{aligned}$$

If L is the original length, then $l = L$

$$\begin{aligned}F &= EA \\ &= 200 \times 10^9 \times 10^{-4} \\ &= 2 \times 10^7 \text{ N}\end{aligned}$$

2.2 VISCOSITY

Let us consider a liquid flowing over a horizontal surface. The layer in contact with the surface is at rest. The top most layer have the maximum velocity. The intermediate layers have intermediate velocity. To maintain this relative motion of the layers, an external force must be acting on the liquid. Otherwise the liquid will come to rest due to internal frictional forces acting between the layers of the liquid. These internal frictional forces that bring the liquid to rest are known as viscous force and this property is known as viscosity.

The property by virtue of which the relative motion between the layers of a liquid is maintained is called viscosity. We can also say viscosity is the resistance to flow.

Coefficient of viscosity of a liquid

Let F be the viscous force acting between two layers of a liquid separated by a distance dx. Let dv be the difference in velocity between the two layers. Let A be the area of the layers. The velocity gradient dv/dx acts perpendicular to direction of flow of the liquid.

The viscous force F is found to be directly proportional to

- i. the area of the layers 'A'
- ii. the velocity gradient $\frac{dv}{dx}$

$$F \propto \frac{Adv}{dx}$$

$$F = \frac{\eta Adv}{dx}$$

If $A = 1$ and $\frac{dv}{dx} = 1$, then $F = \eta$

Where η is constant, called Coefficient of viscosity of the liquid

Coefficient of viscosity of a liquid is defined as the viscous force acting between two layers of a liquid having unit area of layers and unit velocity gradient normal to the direction of flow of the liquid.

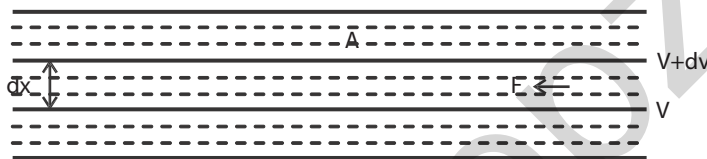

SI unit of η :

$$\eta = \frac{F}{A \, dv / dx}$$

Substituting the respective units of the quantities on the R.H.S,

$$\begin{aligned} \text{The unit of coefficient of viscosity } \eta &= \frac{\text{N}}{\text{m}^2 \cdot \text{ms}^{-1} / \text{m}} \\ &= \text{Nsm}^{-2} \end{aligned}$$

Dimensional formula of η :

$$\eta = \frac{F}{A \, dv / dx}$$

Substituting the respective dimensional formula of the quantities on the R.H.S,

$$\begin{aligned} \text{The dimensional formula of coefficient of viscosity } \eta &= \frac{\text{MLT}^{-2}}{\text{L}^2 \cdot \text{LT}^{-1} / \text{L}} \\ &= \text{ML}^{-1}\text{T}^{-1} \end{aligned}$$

Stream line flow (laminar flow) and turbulent flow:

To maintain the flow of a liquid through a tube, some pressure should be given at one end of the tube to overcome the viscous drag. For a given external pressure, the velocity of flow depends on the coefficient of viscosity. At low pressure the velocity is less than a certain velocity called the critical velocity and the liquid flows in an orderly manner and the flow is called steady flow or streamline flow.

In stream line flow,

1. The liquid particles flow in an orderly manner. i.e., the liquid particles flow along straight lines, each line is called the line of flow.
2. The lines of flow are parallel to the axis of the tube.

3. The velocity of all particles in a line of flow is a constant.
4. The velocity of flow is always less than the critical velocity.
5. Stream line flow will happen only when the driving pressure is small.
6. The flow of water through a capillary tube at the rate of 5 to 6 drops per minute is an example for stream line flow.

When the external pressure causing the flow of the liquid is high, the flow of the liquid is said to be turbulent.

In turbulent flow,

1. There is no orderliness in the flow of liquid.
2. The liquid particles will not flow along straight lines, but will flow in curved paths in a zig-zag manner.
3. The different particles of the liquid will flow in different directions with different velocities.
4. The velocity of flow is always greater than the critical velocity.
5. Turbulent flow will happen when the driving pressure is high.
6. The flow of water from a tap is an example for turbulent flow.

Distinction between streamline motion and turbulent motion

Critical velocity:

When the external pressure driving the flow of liquid increases slowly, the velocity of flow of liquid will also increase gradually. At a particular velocity the flow of liquid will change from laminar flow to turbulent flow. This velocity is called critical velocity. In other word the critical velocity is defined as the velocity at which the streamline flow ceases out and the turbulent flow sets in.

Sl. No.	Stream line motion	Turbulent motion
1	Flow of liquid is orderly.	Flow of liquid is zigzag and random.
2	At any point along a straight line parallel to the axis of the tube, velocity is constant	Velocity varies along the straight line parallel to the axis of the tube.
3.	Velocity is proportional to the pressure.	Velocity is proportional to the square root of pressure
4.	Velocity will always be less than critical velocity	Velocity will always be greater than critical velocity.

Reynolds number:

Reynolds number is a pure number, which determines the type of flow of a liquid, whether a streamline flow or a turbulent flow through a cylindrical pipe. It has no units and dimensions. It is given by the expression

where V is velocity of the liquid, ρ is the density of the liquid, η is the coefficient of viscosity of the liquid and D is the diameter of the pipe. This equation is applicable only for liquids flowing through cylindrical pipe.

$$R = \frac{V\rho D}{\eta}$$

Experiments show that the flow of a viscous liquid is laminar or streamlined, if Reynolds number is less than 2000. The flow of a viscous liquid is turbulent if Reynolds number is more than 2800. Between 2000 and 2800 there is a transition region in which the flow may change from streamline to turbulent.

Narrow tubes and highly viscous liquids tend to promote streamline motion, while wider tubes and liquids of low viscosity leads to turbulence.

Experiment to determine comparison of coefficient of viscosity of two liquid- Capillary flow method.

Aim:

To compare the coefficient of viscosity of two given liquids by capillary flow method,.

Formula:

The comparison of coefficient of viscosity

$$\eta_1 / \eta_2 = \rho_1 / \rho_2 \times t_1 / t_2$$

η_1 = coefficient of viscosity of first liquid

η_2 = coefficient of viscosity of second liquid

ρ_1 = Density of the first liquid

ρ_2 = Density of the second liquid

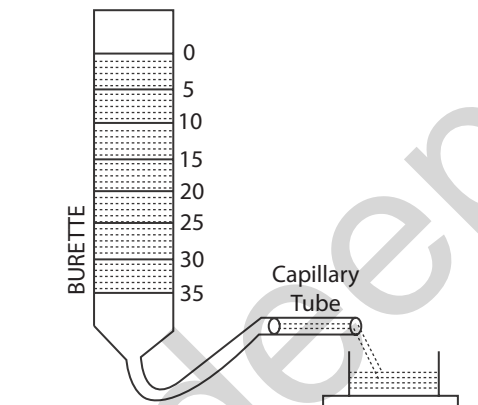

Description:

The graduated burette without stopper is mounted vertically in the stand. A rubber tube is connected to the bottom of the burette. To the other end of the tube, a capillary tube is inserted and placed in a perfectly horizontal position.

Procedure:

The burette is cleaned and filled with one of the liquids using a funnel. Adjust the tube till the liquid through the tube comes out drop by drop. . A stop clock is started when the liquid level reaches 0 c c and time taken for every 5 c c from 5,10, 15,20..till 50 c c, is noted .The burette and the tube are cleaned,rinsed and filled with the second liquid The time taken to cross the every consecutive 5 ml is noted. The reading are tabulated .The time taken for the t_1 and t_2 are noted. The mean value of t_1 / t_2 is calculated

Burette reading (cc)	Time (S)		t_1 / t_2
	Liquid-I(t_1)	Liquid-II (t_2)	
0-5			
5-10			
-			
-			
-			
45-50.			

Mean

Terminal velocity

When a small metallic sphere is gently placed on the surface of a highly viscous liquid it descends down with an acceleration. As its velocity increases, the viscous force opposing the motion of the sphere also increases.

At some stage the apparent weight of the sphere becomes equal to the force due to viscous drag. So the resultant force on the sphere is zero. Therefore the sphere moves down with a constant velocity known as terminal velocity.

Terminal velocity is that velocity at which the apparent weight of the sphere is equal to the viscous force acting on the sphere moving in a high viscous liquid.

Experimental determination of the coefficient of viscosity of a high viscous liquid by Stokes' method:

Aim:

To determine the coefficient of viscosity of highly viscous liquid (Castor oil) by Stokes' method.

Formula:

The coefficient of viscosity of the highly viscous liquid

$$\eta = \frac{2(\rho - \sigma)g(r^2t)}{9h}$$

where

ρ = the density of the material of the solid sphere (glass beads)

σ = the density of the liquid (castor oil)

g = the acceleration due to gravity

r = the radius of the glass beads

t = the time taken by the solid sphere to travel the marked distance h , inside the high viscous liquid.

h = the distance between the marks B and C

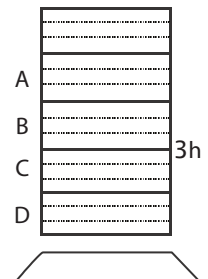

Description:

The pure, transparent, highly viscous liquid (castor oil) is taken in the tall glass jar. On the outer surface of the jar, two markings B and C or C and D are made at a distance of say 50 cm. The marking B should be well below the free surface of the liquid. Then only the sphere can attain terminal velocity when travelling from B to C or C to D.

Procedure:

First the least count, zero error and zero correction of screw gauge are determined. Then using the screw gauge, the diameters of the given glass beads are measured. The radii of the beads are calculated. Values of r and s are taken from standard tables.

The sphere is placed gently on the surface of the highly viscous liquid and dropped. When it crosses the marking B, a stop clock is started and when it crosses the marking C, the clock is stopped. The time taken (t) to travel by the sphere from B to C is recorded in the tabular column. The distance between B and C is noted as ' h '. The same procedure is repeated for all the given spheres. Then the coefficient of viscosity of highly viscous liquid (castor oil) is calculated, using the formula.

Tabular column:To find r^2t

Glass beads	Radius (r)	Radius ² (r ²)	Time taken (t)	r ² t
Unit	mm	mm ²	s	mm ² s
Bead 1				
Bead 2				
Bead 3				

$$\begin{aligned} \text{The average of } r^2t &= \text{mm}^2\text{s} \\ &= \times 10^{-6} \text{ m}^2\text{s} \end{aligned}$$

Applications of viscosity

To reduce friction between the two moving surfaces which are in contact, a drop or two of some oil is introduced between the two contact surfaces. The oil enters into the depressions in the contact surfaces and form a thin layer so that direct contact between the surfaces is prevented. Now, the viscous force of the oil in between the surfaces (lubricant) reduces the friction between the two moving surfaces because the fluid friction is always less than the friction between the solid surfaces. However a good viscous lubricant can only reduce friction, but cannot completely eliminate the friction.

Generally, for high speeds and low pressures, highly viscous oils such as Mobil oil, grease, etc. are used. For low speeds, oils of lower viscosity are used. It may be interesting to note that air also acts as a sort of lubricant in reducing friction. The friction between two metallic surfaces in vacuum is found to be greater than that in air.

2.3 SURFACE TENSION**Introduction**

The free surface of a liquid at rest behaves like a stretched elastic membrane with a tendency to contract in area. The following simple experiments will illustrate this property.

1. When a camel hairbrush is dipped into water, the hairs remain spread out. When the brush is taken out, the hairs cling together on account of the films of water between them contracting.
2. A film of the soap solution is formed in a wire ring. If a wetted loop of thread is gently placed on the film, the film is unaffected and the thread remains in any form in which it is placed on the film. But if the film is pricked inside the loop, the film outside contracts on all sides and hence the circular loop is formed. The area of the film is reduced to a minimum.

The above examples show that a force acts on the surface of liquid to reduce the surface area to a minimum. This force is known as surface tension.

A water drop takes the spherical shape because for a given volume, sphere has the minimum surface area. This is due to surface tension.

Surface tension

Surface tension is the force acting on unit length of an imaginary line drawn on the free surface of a liquid, the force acting normal to the line and parallel to the surface. The unit of surface tension is Nm^{-1} and its dimension is MT^{-2}

Angle of contact

The angle of contact is the angle by which the tangent drawn to the liquid surface at the point of contact with the solid, makes with the surface of the solid, the angle being measured within the liquid.

For liquids like water and kerosene which spread on glass, the angle of contact $\theta = 0^\circ$. In the case of mercury and clean glass, the angle of contact $\theta = 137^\circ$. For ordinary water and glass, the angle of contact $\theta = 8^\circ$.

When a glass rod is dipped vertically in water, which wets the glass, the water is drawn up around the glass rod at all points of contact. Here, the angle of contact is acute. When a glass rod is dipped vertically in mercury, which does not wet the glass, the liquid is depressed around the glass rod at all points of contact. Here, the angle of contact is obtuse.

Expression for the surface tension by capillary rise:

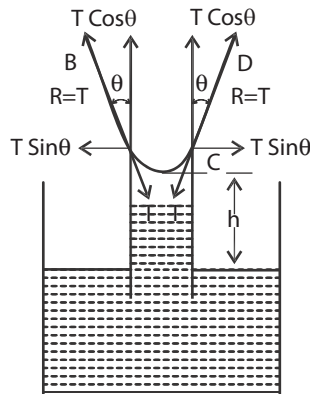

Let a capillary tube of uniform radius (r) be dipped vertically into a liquid of density ρ taken in a beaker. Let the liquid rises through a height (h) in the capillary tube. Let θ be the angle of contact with glass and T be the surface tension of the liquid. The surface tension is acting tangential to the liquid surface. The reaction $R=T$, offered by the walls of tube acts at an angle θ to the verticals. This reaction T along AB can be resolved vertically as $T\cos\theta$ and horizontally as $T\sin\theta$. Similarly the reaction T along CD can also be resolved along the horizontal and vertical directions. The horizontal components along the circumference are equal and opposite in direction. So they get cancelled. So the total force due to surface tension is only due to vertical components.

$$\begin{aligned} \text{The total upward force acting through the length of the meniscus } 2\pi r \\ = 2\pi r \cdot T \cos\theta \end{aligned}$$

This force balances the weight of the liquid column of height h and radius r .

The weight of the liquid column $= \pi r^2 h \rho g$

$$2\pi r T \cos\theta = \pi r^2 h \rho g$$

$$T = \frac{hr\rho g}{2\cos\theta}$$

In the case of water $\theta = 0^\circ$ and hence $\cos\theta = 1$

Hence for water, Surface tension

$$T = \frac{hr\rho g}{2}$$

Experimental determination of the surface tension of water by capillary rise method.

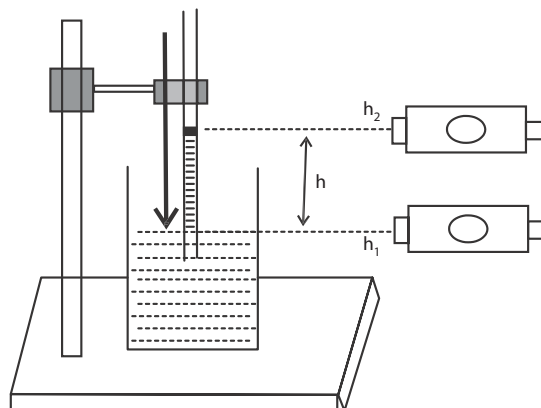

A capillary tube of uniform cross sectional area is first cleaned with dilute acid and washed with distilled water and dried. It is then clamped vertically with one end inside the water taken in a beaker. Due to surface tension, water rises to a definite height in the tube. A pointer is attached to the capillary tube such that it just touches the surface of the water in the beaker.

Using a travelling microscope the reading in the vertical scale corresponding to the lower meniscus of the water in the tube is taken. The beaker is removed and the microscope is brought down and the reading corresponding to the tip of the pointer is taken. The difference between the two readings gives the height of the capillary rise of water 'h' in the capillary tube. The diameter and hence the radius 'r' of the capillary tube is also determined with the help of microscope. If ρ is the density of water and g, the acceleration due to gravity, then surface tension of water,

$$T = \frac{hr\rho g}{2}$$

Applications of capillarity:

1. Lubricating oil spread easily on all parts because of their low surface tension.
2. Cotton dresses are preferred in summer because cotton dresses have fine pores which act as capillaries for sweat.
3. Dirt get removed when detergents are added while washing clothes because surface tension of water is reduced.
4. The absorption of ink by a blotting paper is due to capillary action, as the blotting paper is porous. When it is placed over the ink, the ink raises into the pores. Also rise of oil in the wick of a lamp is due to capillary action.
5. If one end of a towel is dipped into a bucket of water and the other end hangs over the bucket, the entire towel soon becomes wet due to capillary action.
6. The supply of water to the leaves at the top of even a tall tree is through capillary rise.
7. A fabric can be waterproof, by adding suitable waterproofing materials to the fabric. This addition increases the angle of contact, thereby making the fabric waterproof.

Worked examples

1. A capillary tube of diameter 0.5 mm is dipped into a liquid vertically and the liquid rises to a height of 6 cm. If the density of the liquid is 1000 kgm^{-3} , calculate the value of surface tension of the liquid. ($g = 9.81 \text{ ms}^{-2}$)

Diameter of the capillary tube $2r = 0.5 \text{ mm}$

Radius of the capillary tube $r = 0.25 \times 10^{-3} \text{ m}$

Rise of liquid in the tube $h = 6 \text{ cm} = 6 \times 10^{-2} \text{ m}$

Density of the liquid $\rho = 1000 \text{ kg m}^{-3}$

Liquid being water, angle of contact $\theta = 0^\circ$

$$\text{Surface tension of the liquid } T = \frac{h\rho g r}{2 \cos \theta}$$

$$\frac{6 \times 10^{-2} \times 1000 \times 9.81 \times 0.25 \times 10^{-3}}{2 \cos \theta}$$

$$T = 72.5 \times 10^{-3} \text{ Nm}^{-1}$$

2. Calculate the diameter of a capillary tube in which a liquid rises 2.34×10^{-2} m. Surface tension of the liquid is $25 \times 10^{-3} \text{ Nm}^{-1}$. Relative density of the liquid is 0.79. Angle of contact = $11^\circ 12'$. ($g = 9.81 \text{ ms}^{-2}$)

Relative density of the liquid = 0.79

Density of the liquid $\rho = 0.79 \times 10^3 \text{ kgm}^{-3}$

Diameter of the tube = $2r = 5.41 \times 10^{-4} \text{ m}$

$$\text{We know } T = \frac{h\rho gr}{2 \cos \theta}$$

$$r = \frac{2T \cos \theta}{h\rho g}$$

$$= \frac{2 \times 25 \times 10^{-3} \cos 11^\circ 12'}{2.34 \times 10^{-2} \times 0.79 \times 10^3 \times 9.81} = 2.705 \times 10^{-4} \text{ m}$$

3. A liquid of density 1000 kgm^{-3} is taken in a beaker. A capillary tube of diameter 1.0 mm is dipped vertically in it. Calculate the rise of liquid in the tube. Surface tension of the liquid is $72 \times 10^{-3} \text{ Nm}^{-1}$.

For water, angle of contact $\theta = 0^\circ$

Surface tension $T = 72 \times 10^{-3} \text{ Nm}^{-1}$

Diameter of the capillary tube $2r = 1 \text{ mm}$

Radius of the capillary tube $r = 0.5 \times 10^{-3} \text{ m}$

$h = 2.939 \times 10^{-2} \text{ m}$

$$\text{Rise of liquid in the tube } h = \frac{2T \cos \theta}{r\rho g}$$

$$h = \frac{2 \times 72 \times 10^{-3} \cos 0^\circ}{0.5 \times 10^{-3} \times 1000 \times 9.8} = 2.939 \times 10^{-2} \text{ m}$$

4. A capillary tube of internal diameter 0.5 mm is dipped into a liquid of density 1140 kgm^{-3} . The liquid rises to a height of 2.6 cm in the capillary tube. If the angle of contact of liquid with glass is 55° , calculate the surface tension of the liquid.

Diameter of the capillary tube = 0.6 mm

Radius of the capillary tube $r = 0.3 \times 10^{-3} \text{ m}$

Density of the liquid, $\rho = 1140 \text{ kg m}^{-3}$

Height through which liquid rises $h = 2.6 \times 10^{-2} \text{ m}$

Angle of contact, $\theta = 55^\circ$

$$\text{Surface tension of the liquid } T = \frac{h\rho gr}{2 \cos \theta}$$

$$T = \frac{2.6 \times 10^{-2} \times 0.3 \times 10^{-3} \times 1140 \times 9.8}{2 \cos 55^\circ}$$

$$T = 75.96 \times 10^{-3} \text{ Nm}^{-1}$$

QUESTIONS

Part -A and Part- B

1. Define stress
2. Define strain
3. Which is more elastic, rubber or steel and why?
4. What is elastic limit and plastic limit?
5. Define elastic body and plastic body.
6. What are the three moduli of elasticity?
7. Define (i) linear strain (ii) bulk strain and (iii) shearing strain.
8. Write the statement of Hooke's law.
9. Define Modulus of elasticity
10. Define (i) Young's modulus (ii) Bulk modulus and (iii) Rigidity modulus.
11. Define Poisson's ratio.
12. What is uniform bending of a beam?
13. What is non uniform bending of a beam?
14. Define coefficient of viscosity.
15. Derive the dimensional formula and the SI unit for the coefficient of viscosity.
16. What is stream line motion?
17. What is turbulent motion?
18. What is Reynolds number?
19. What is critical velocity?
20. What is terminal velocity?
21. Write the application of viscosity.
22. Derive the S.I. unit and the dimensional formula of surface tension.
23. What is the effect of surface tension on the surface area of liquids?
24. The droplet of rain is spherical. Why?
25. How do insects run on the surface of water?
26. Define surface tension of a liquid.
27. Define angle of contact.
28. Write any two applications of capillarity.
29. What are uniform bending of beams.
30. What are non-uniform bending of beams
31. Explain young's modulus
32. Explain Bulk modulus
33. Explain Rigidity modulus
34. Explain stream line motion
35. Explain turbulent motion

Part - C

1. Explain three types of modulus
2. Describe an experiment to determine the Young's modulus of the material of a bar by bending it uniformly.
3. Distinguish between stream line and turbulent motion.
4. Describe an experiment to determine the comparison of coefficient of viscosity of two viscous liquid by capillary flow method.
5. Describe Stokes' method of determining the coefficient of viscosity of a transparent, high viscous liquid.
6. Derive an expression for the surface tension of a liquid in the case of the capillary rise.
7. Describe an experiment to determine the surface tension of water by capillary rise method.
8. List the various applications of capillarity.

Exercise Problems

1. The length of a wire increases from 1.25 m to 1.2508 m when a load of 12 kg is suspended. The radius of the wire is 0.5 mm. Find the stress, strain and young's modulus of material of the wire.

$$\text{Ans: } (149.7 \times 10^6 \text{ Nm}^{-2}, 6.4 \times 10^{-4}, 23.4 \times 10^{10} \text{ Nm}^{-2})$$

2. What load in kilogram must be applied to a steel wire of length 1m and diameter 0.05 cm to produce an extension of 1 cm. The Young's modulus of steel = 2×10^{11} Pa.

$$\text{Ans: } 40 \text{ kg}$$

3. A wire 10m long of area of cross section 1.22cm^2 elongates by 1.5 cm when 4.5 kg is suspended from it. Find the (i) stress (ii) strain and (iii) young's modulus of the wire. ($g = 9.8\text{m s}^{-2}$)

$$\text{Ans: } (i) 3.528 \times 10^5 \text{ Nm}^{-2} \text{ (ii) } 0.0015 \text{ (iii) } 2.352 \times 10^8 \text{ Nm}^{-2}$$

4. A body of mass 5kg is suspended by means of a steel wire of length 1 m and diameter 1mm. The Young's modulus of steel is $21 \times 10^{10} \text{ Nm}^{-2}$, calculate the elongation of the wire.

$$\text{Ans: } l = 2.97 \times 10^{-4} \text{ m}$$

5. A uniform metal bar, one metre long, is placed symmetrically on two knife-edges separated by a distance of 64.2 cm. When two equal weights of 0.5 kg each are suspended from points 5cm from the two ends respectively, the mid-point of the bar is elevated by 0.76 mm. Calculate the Young's modulus of the material of the bar if the width of the bar is 2.2 cm and its thickness 0.62 cm.

$$\text{Ans: } 9.81 \times 10^{10} \text{ Nm}^{-2}$$

6. Calculate the surface tension of water if it rises to a height of 4.2cm in a capillary tube dipped vertically in it. Radius of the capillary tube is 3.5×10^{-4} m.

$$\text{Ans: } 72.03 \times 10^{-3} \text{ Nm}^{-1}$$

7. A capillary tube of diameter 0.5 m is dipped into a liquid vertically and the liquid rises to a height of 4.4 cm. If the density of the liquid is 1000 kg m^{-3} , calculate the value of the surface tension of the liquid.

8. A capillary tube of bore 0.84 mm in dipped into a liquid of density 840 kg m^{-3} and surface tension 0.049 Nm^{-1} . Find the rise of the liquid in the tube.

Brain teasers

1. A wire of diameter 2.5 mm is stretched by force of 980 N. If the Young's modulus of the material of the wire is $12.5 \times 10^{10} \text{ Nm}^{-2}$. Find the percentage increase in the length of the wire.
2. Two wires are made of same material. The length of the first wire is half of the second wire and its diameter is double that of the second wire. If equal loads are applied on both the wires find the ratio of increase in their lengths.
3. The diameter of a brass rod is 4 mm. Calculate the stress and strain when it is stretched by 0.25% of its length. Find the force exerted ($E = 9.2 \times 10^{10} \text{ Nm}^{-2}$ for brass)

UNIT

3

DYNAMICS - I

3.1 STRAIGHT LINE MOTION

Introduction:

Dynamics is a branch of mechanics which deals with the motion of the bodies under the action of forces.

A body is said to be at rest if it does not change its place or position with respect to its surroundings. No body in this earth is at absolute rest. Because, they are sharing the motion of the earth. A body can be at rest with respect to another body.

A body is said to be in motion if it changes its place or position with respect to its surroundings. For example, a person in the moving train feels the motion, seeing the passing objects through the windows. Hence rest and motion are relative terms.

The motion of the body is characterised by two quantities, Force and Momentum. If a body is in motion with acceleration, then the body is acted upon by a force ($F=ma$). If a body is in motion with uniform velocity, there is no acceleration, then the motion of the body is only under momentum (mv).

Newton's Laws of motion: These laws are very important in dynamics.

I Law: Every body continues to be in its state of rest or of uniform motion in a straight line unless compelled by an external force.

II Law: The rate of change of momentum of a body is directly proportional to the force acting on it and it takes place in the direction of the force.

III Law: For every action, there is always an equal and opposite reaction.

In this unit we shall study about the Projectile motion, Circular motion, its application and Simple Harmonic Motion.

In this chapter we shall consider the motion of the objects projected in any direction from the earth making the following assumptions.

- 1) The air resistance is negligible
- 2) The acceleration due to gravity remains constant.

When an object is projected vertically up from the earth, we regard the upward direction as the positive direction. The force of gravity produces acceleration downwards on the object. Acceleration is therefore taken as negative.

Equations of motion: Let u = initial velocity, v = final velocity, a = acceleration, t = time and s = displacement.

(I) For Objects in motion

- (1) $v = u + at$
- (2) $s = ut + \frac{1}{2} at^2$
- (3) $v^2 = u^2 + 2as$

(ii) For objects falling freely

Here initial velocity $u = 0$ and $a = +g$

- (1) $v = gt$
- (2) $S = \frac{1}{2} gt^2$
- (3) $v^2 = 2gs$

(iii) For objects thrown vertically upwards

Here $a = -g$

- (1) $v = u - gt$
- (2) $s = ut - \frac{1}{2} gt^2$
- (3) $v^2 = u^2 - 2gs$

3.2 PROJECTILE MOTION**Projectile**

Projectile is any object thrown obliquely into the space. The object which is given an initial velocity and afterwards follows a path determined by the gravitational force acting on it is called projectile. Its motion is called projectile motion.

A stone projected at an angle, a bomb released from an aeroplane, a shot fired from a gun, a shotput or javelin thrown by the athlete are the various examples for the projectile.

Consider a body projected from a point 'O' with velocity 'u'. The point 'o' is called point of projection and 'u' is called velocity of projection.

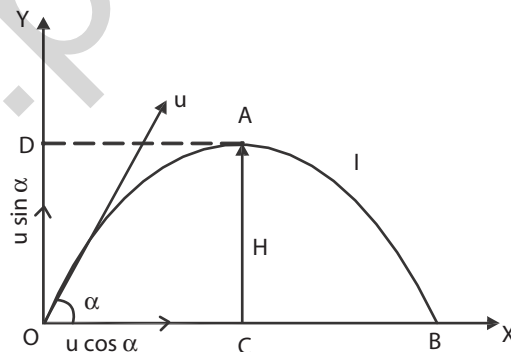

Velocity of Projection (u): The velocity with which the body projected is called velocity of projection.

Angle of Projection (a): The angle between the direction of projection and the horizontal plane passing through the point of projection is called angle of projection.

Trajectory (OAB): The path described by the projectile from the point of projection to the point where the projectile reaches the horizontal plane passing through the point of projection is called trajectory. The trajectory of the projectile is a parabola.

Maximum height (H): The maximum vertical displacement of the projectile from the horizontal plane passing through the point of projection is called maximum height.

Time of flight (T): The time taken by the projectile to travel from the instant of projection to the instant when it reaches the horizontal plane passing through the point of projection is called time of flight (or) The time taken by the projectile to describe the trajectory.

Range (R): The distance between the point of projection and the point where the projectile reaches the horizontal plane passing through the point of projection is called the range of the projectile.

Note: The horizontal component of velocity $u \cos \alpha$ is constant throughout the motion and the vertical component of velocity $u \sin \alpha$ goes on decreasing and becomes zero at the highest point A, because of the constant retardation '-g' acting on the projectile.

Expressions for maximum height, time of flight and horizontal range of a projectile.

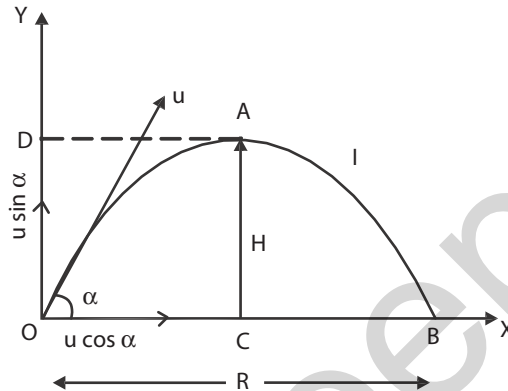

Consider a body be projected upwards from the point of projection O with the velocity u . Let α be the angle of projection. The velocity u can be resolved into two components. Let $u \sin \alpha$ and $u \cos \alpha$ are the vertical and horizontal components of the velocity.

Maximum height reached by the projectile:

Let H be the maximum height reached by the projectile. At the highest point the vertical component of velocity becomes zero.

Considering the vertical motion of the projectile,

Taking the equation of motion

$$v^2 = u^2 + 2as \quad \dots(1)$$

Final velocity at A, $v = 0$

Initial velocity at O, along vertical direction $u = u \sin \alpha$

Acceleration $a = -g$

Vertical displacement AC, $s = H$

Substituting these values in equation (1)

$$0 = u^2 \sin^2 \alpha + 2(-g) H$$

$$0 = u^2 \sin^2 \alpha - 2gH$$

$$2gH = u^2 \sin^2 \alpha$$

$$\therefore \text{Maximum height, } H = \frac{u^2 \sin^2 \alpha}{2g}$$

Time of Flight of the Projectile:

The time taken by the projectile to describe the path is called time of flight. i.e., It is the time taken by the projectile to travel from 'O' to 'B', via A.

Let T be the time of flight. Here, the vertical displacement at B is zero.

Considering the vertical motion, Taking the equation of motion

$$S = ut + \frac{1}{2} at^2 \quad (2)$$

Vertical displacement $S = 0$

Initial velocity at O, along vertical direction $u = u \sin \alpha$

Acceleration $a = -g$; Time $t = T$; Substituting these values in equation (2)

$$0 = u \sin \alpha T + \frac{1}{2} (-g)T^2$$

$$0 = u \sin \alpha T - \frac{1}{2} g T^2$$

$$\frac{1}{2} g T^2 = u \sin \alpha T$$

$$\therefore \text{Time of flight, } T = \frac{2u \sin \alpha}{g}$$

Horizontal Range of the Projectile :

The horizontal distance between the point of projection and the point where the projectile meets the horizontal plane passing through the point of projection is called range of the projectile.

Let R be the range of the projectile.

Range $R = \text{Horizontal component of velocity} \times \text{Time of flight}$

$$R = u \cos \alpha \times \frac{2u \sin \alpha}{g}$$

$$= \frac{u^2 \sin \alpha \cos \alpha}{g}$$

$$\therefore \text{Range, } R = \frac{u^2 \sin 2\alpha}{g}$$

Condition for maximum range (R_{\max}):

The expression for Horizontal Range, $R = \frac{u^2 \sin 2\alpha}{g}$

For a given velocity of projection, range will be maximum only when $\sin 2\alpha$ is maximum. The maximum value for sine function is 1.

i.e $\sin 2\alpha = 1$ but, $\sin 90^\circ = 1$

$$\therefore \sin 2\alpha = \sin 90^\circ \therefore 2\alpha = 90^\circ \quad \therefore \alpha = 45^\circ$$

For getting maximum range, the condition is the angle of projection should be 45° .

$$\therefore \text{Maximum range, } R_{\max} = \frac{u^2 \sin (2 \times 45^\circ)}{g}$$

$$R_{\max} = \frac{u^2 \sin 90^\circ}{g} = \frac{u^2}{g} \quad (\because \sin 90^\circ = 1)$$

$$R_{\max} = \frac{u^2}{g}$$

This is the expression for the maximum range of the projectile.

Path of the projectile (the trajectory) is a Parabola:

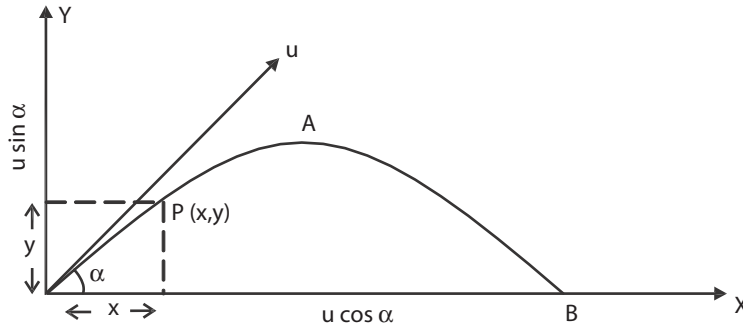

Consider a body be projected from the point of projection O with the velocity u as shown in the figure. Let α be the angle of projection of the body. The velocity u can be resolved into two components. $u \sin \alpha$ and $u \cos \alpha$ are the vertical and horizontal components of velocity u. Let P (x,y)

Horizontal displacement in t second, $x = u \cos \alpha \times t$

$$t = \frac{x}{u \cos \alpha}$$

Taking the equation of motion $S = ut + \frac{1}{2} at^2$ -----> (1) be the position of the body after 't' second.

Vertical displacement in t second, $S = y$

Time taken to reach P, $t = \frac{x}{u \cos \alpha}$

Initial velocity at O along vertical direction, $u = u \sin \alpha$

Acceleration $a = -g$

$$y = u \sin \alpha \frac{x}{u \cos \alpha} + \frac{1}{2} (-g) \frac{x^2}{u^2 \cos^2 \alpha}$$

$$y = x \tan \alpha - \frac{g}{2u^2 \cos^2 \alpha} x^2$$

$$y = x \tan \alpha - \frac{gx^2}{2u^2 \cos^2 \alpha}$$

Substituting these values in equation (1)

The above equation is similar to the equation of the parabola $y = bx - cx^2$. Hence the path of the projectile is a parabola.

SOLVED PROBLEMS

1. A body is thrown with a velocity of projection 49 ms^{-1} at an angle of projection 45° . Find (i) Maximum height (ii) Time of flight (iii) Range ($g = 9.8 \text{ ms}^{-2}$).

Given

$$u = 49 \text{ms}^{-1}$$

$$\alpha = 45^\circ$$

Maximum height, $H = \frac{u^2 \sin^2 \alpha}{2g}$

$$= \frac{49 \times 49 \times \sin 45^\circ \times \sin 45^\circ}{2 \times 9.8}$$

$$= 61.25 \text{ m}$$

$$\begin{aligned}\text{Time of flight, } T &= \frac{2u \sin \alpha}{g} \\ &= \frac{2 \times 49 \times \sin 45}{9.8} \\ &= 7.07 \text{ s}\end{aligned}$$

$$\begin{aligned}\text{Range, } R &= \frac{u^2 \sin 2\alpha}{g} \\ &= \frac{49 \times 49 \times \sin (2 \times 45)}{9.8} \\ &= \frac{49 \times 49 \times \sin 90}{9.8} \\ &= 245 \text{ m}\end{aligned}$$

2. A bullet fired from a gun with a velocity of 80 ms^{-1} strikes the ground at the same level as the gun at a distance of 460 m . Find the angle of inclination with the horizontal at which the gun was fired.

Given

$$u = 80 \text{ ms}^{-1}, R = 460 \text{ m}, g = 9.8 \text{ ms}^{-2}$$

$$\text{Range } R = \frac{u^2 \sin 2\alpha}{g}$$

$$\sin 2\alpha = \frac{g.R}{u^2} = \frac{9.8 \times 460}{(80)^2} = 0.7044$$

$$2\alpha = \sin^{-1}(0.7044) = 44^\circ 46'$$

$$\therefore \alpha = 22^\circ 23'$$

3. The range of a projectile is equal to double the maximum height attained. Find the angle of projection.

Given

$$\text{Horizontal range} = 2 \times \text{maximum height}$$

$$\text{ie., } R = 2H$$

$$\frac{u^2 \sin 2\alpha}{g} = 2 \frac{u^2 \sin^2 \alpha}{2g}$$

$$\sin 2\alpha = \sin^2 \alpha$$

$$2 \sin \alpha \cos \alpha = \sin \alpha \sin \alpha$$

$$2 \cos \alpha = \sin \alpha$$

$$\therefore \tan \alpha = 2$$

$$\therefore \alpha = \tan^{-1}(2) = 63^\circ 26'$$

4. A projectile is thrown at an angle and another is thrown at $(90 - \theta)$ from the same point both with the velocities 78.4 ms^{-1} . The second reaches 36.4 m higher than the first. Find the individual heights.

Given

$$\text{Angle of projection of first projectile} = \theta$$

$$\text{Angle of projection of second projectile} = (90 - \theta) \text{ Velocity of projection } u = 78.4 \text{ ms}^{-1}$$

$$\text{and } H_2 = H_1 + 36.4 \text{ m}$$

$$H_2 - H_1 = 36.4 \text{ m}$$

Where H_1 is the maximum height of first one and H_2 is the maximum height of second one.

$$H_1 = \frac{u^2 \sin^2 \theta}{2g} \text{ and } H_2 = \frac{u^2 \sin^2 (90 - \theta)}{2g} = \frac{u^2 \cos^2 \theta}{2g}$$

$$\begin{aligned} \text{Adding, } H_2 + H_1 &= \frac{u^2 \cos^2 \theta}{2g} + \frac{u^2 \sin^2 \theta}{2g} \\ &= \frac{u^2}{2g} = \frac{78.4 \times 78.4}{2 \times 9.8} = 313.6 \\ 2H_2 &= 36.4 + 313.6 = 350 \\ H_2 &= 175 \text{ m} \end{aligned}$$

$$\text{Also, } H_1 = H_2 - 36.4 = 175 - 36.4$$

$$H_1 = 138.6 \text{ m}$$

5. If the range of a projectile is and $256\sqrt{3}$ m the maximum height reached is 64m. Calculate the angle of projection.

Given

$$H = 64 \text{ m } R = 256\sqrt{3} \text{ m}$$

$$\begin{aligned} \text{Maximum height } H &= \frac{u^2 \sin^2 \alpha}{2g} \\ 64 &= \frac{u^2 \sin^2 \alpha}{2g} \end{aligned} \quad (1)$$

$$\begin{aligned} \text{Range, } R &= \frac{u^2 2 \sin \alpha \cos \alpha}{g} \\ 256\sqrt{3} &= \frac{u^2 2 \sin \alpha \cos \alpha}{g} \end{aligned} \quad (2)$$

Dividing eqn. (1) by (2)

$$\frac{64}{256\sqrt{3}} = \frac{u^2 \sin^2 \alpha}{2g} \times \frac{g}{u^2 2 \sin \alpha \cos \alpha} = \frac{\tan \alpha}{4}$$

$$\tan \alpha = \frac{1}{\sqrt{3}} \quad \alpha = \tan^{-1} \left(\frac{1}{\sqrt{3}} \right)$$

$$\alpha = 30^\circ$$

3.3 CIRCULAR MOTION

Introduction

In this chapter we study the motion of the bodies moving in a circular path. The motion of the body in a circular path is called circular motion. The motion of the body in the circular path with uniform velocity is called uniform circular motion. When it is in uniform velocity, the direction of motion at any point is along the tangent to the circle at that point. If the body is set free, it would move in the direction of the tangent at that point.

Angular velocity

Consider a body (or particle) moving along a circular path. If θ is the angle turned by the radius vector in t second, then

$$\text{Angular velocity } \omega = \frac{\theta}{t}$$

The angle covered or swept or turned by the radius vector in one second is known as angular velocity.

SI Unit of angular velocity is radian / second (rad s^{-1})

Radian is the angle made at the centre of the circle by an arc whose length is equal to the radius of the circle.

Relation between angular velocity and linear velocity

Consider a particle moving along a circular path of radius r . Initially the particle is at a point A. After t second the particle reaches the point B. Let θ be the angle swept by the radius vector in t -second.

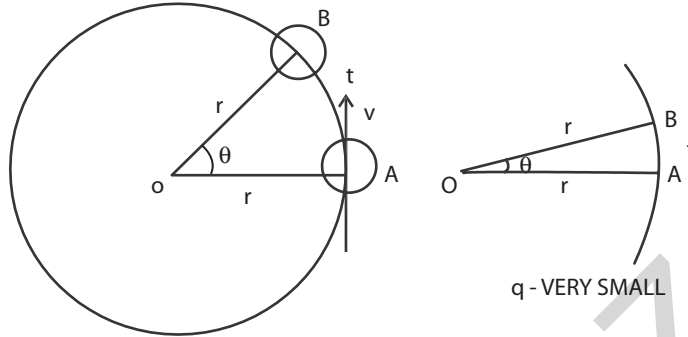

Angular velocity $\omega = \frac{\theta}{t}$

If θ is very small, the distance AB will be considered as a straight line. Let v be the linear velocity of the particle.

Linear velocity, $v = \frac{s}{t}$

In ΔOAB , $\sin \theta = \frac{s}{r}$

If θ is very small, $\sin \theta = \theta$ in radian

$\therefore \theta = \frac{s}{r}$ (or) $s = r \theta$

Linear velocity, $v = \frac{r \theta}{t} = r \omega$

$\therefore v = r \omega$

$\left(\because \omega = \frac{\theta}{t} \right)$

Linear velocity = Radius of the circle \times Angular velocity

Note:

If $\theta = 1^\circ$, $1^\circ = 0.0175$ radian; Also $\sin 1^\circ = 0.0175$

Then $\sin 0.0175$ (radian) = 0.0175 (natural value)

$\theta = 2^\circ = 0.0349$ radian; Also $\sin 2^\circ = 0.0349$

Then $\sin 0.0349$ (radian) = 0.0349 (natural value) Hence $\sin \theta = \theta$ for very small values of θ .

It is practically valid up to $= 4^\circ = 0.0698$ radian.

Period and frequency of revolution

Period (T): Period of revolution of a particle is the time taken by the particle to complete one revolution.

Frequency (n): Frequency of revolution of a particle is the number of revolutions made in one second.

Relation between period T and angular velocity ω :

For one complete revolution (in T second),

Angle turned by the radius vector in T second = 2π

\therefore Angle turned by the radius vector in one second = $\frac{2\pi}{T}$

i.e., Angular velocity, $\omega = \frac{2\pi}{T}$ or $T = \frac{2\pi}{\omega}$

Relation between period T and frequency n:

Let the particle completes n rotations in one second.

This is called frequency. So, the time taken complete one rotation which gives period = $1/n$.

Therefore, $T = 1/n$.

Relation between frequency n and angular velocity ω :

No. of revolutions in 1 second = n

Angle turned by the radius vector for one revolution = 2π

\therefore Angle covered by the radius vector for n revolutions in 1 second = $2\pi n$

i.e., Angular velocity, $\omega = 2\pi n$

Normal acceleration:

For a particle in uniform circular motion, the direction of its velocity changes continuously but the magnitude remains constant. For this, a force must act along the radius, towards the centre of the circle, to maintain the circular path. Hence, there is acceleration acting on the body towards the centre of the circle.

Thus, for a particle executing uniform circular motion, there must always be acceleration directed towards the centre of the circular path along the radius. This acceleration is called normal acceleration and the force responsible for this acceleration is known as centripetal force.

When a particle is moving along a circular path, the particle is accelerated towards the centre of the circular path in a direction normal to the direction of its motion. This acceleration of the particle is known as normal acceleration.

Centripetal force and Centrifugal force:

When a particle is moving along a circular path, it is accelerated towards the centre of the circular path. Due to this acceleration there must be force acting on the particle towards the centre and this force is known as centripetal force.

Centripetal force is defined as the force which acts towards the centre along the radius of the circular path on which the particle is moving with uniform velocity.

Let a stone be tied to one end of a string and whirled in a horizontal plane with constant speed. The stone is subjected to a force directed towards the centre of the circle. This force acting towards the centre of the circle is called centripetal force.

The expression for centripetal force is given by

$$\frac{mv^2}{r} = \text{or } mr\omega^2$$

By Newton's third law, there must be a reaction to this force. This reactive force which is directed away from the centre is called centrifugal force.

The centrifugal force is defined as the force acting along the radius of the circle, away from the centre, to balance the centripetal force.

The centripetal force and centrifugal force are equal in magnitude but opposite in direction. As centrifugal force is a reaction force, it ceases once the centripetal force stops.

Examples for centripetal force:

The centripetal force is responsible for circular motion. Without this force the body cannot move along a circular path. This force can be produced in different ways.

1. A body tied to one end of a string is being rotated in a circle; the centripetal force is supplied by the tension of the string.
2. The moon revolving around the earth, the centripetal force is the gravitational pull of the earth on the moon.
3. A person riding a cycle along a circular path, the necessary centripetal force is supplied by a sidewise pressure exerted by the road on the tyres.

Examples for centrifugal force:

1. A stone tied to one end of a string is being rotated in a circle, the stone itself exerts an equal and opposite force on the hand. It is due to the centrifugal force.
2. A centrifugal pump is used to pump well water on the basis of centrifugal force.

Expressions for Normal acceleration and Centripetal force

Consider a particle of mass 'm' moving along a circular path of radius r. Let v be the velocity of the particle. Initially the particle is at a point A. After t second the particle reaches the point B. Let θ be the angle covered by the radius vector. Let B be very close to A, so that the angle covered θ is small.

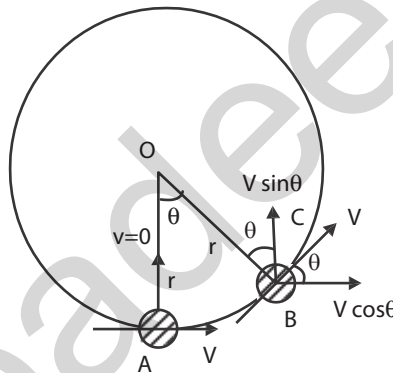

Angular velocity, $\omega = \frac{\theta}{t}$

Initially,

The velocity component in AO direction = zero

After t second

The velocity component in BC direction = $v \sin \theta$

Since θ is very small, the direction BC is very close to AO direction.

\therefore The change in velocity towards the center of the circle in

't' second = $v \sin \theta - 0$

= $v \sin \theta$

As θ is very small, $\sin \theta = \theta$ (in radian)

The change in velocity in one second = $\frac{v \sin \theta}{t}$

ie., Normal acceleration, $a = \frac{v \sin \theta}{t}$

\therefore Normal acceleration, $a = \frac{v\theta}{t}$

$$\text{Since } \omega = \frac{\theta}{t}, a = v\omega$$

$$\text{since } v = r\omega, a = r\omega \cdot \omega = r\omega^2$$

$$\text{since } \omega = \frac{v}{r}, a = v \frac{v}{r} = \frac{v^2}{r}$$

$$\text{Normal acceleration, } a = \frac{v^2}{r} \text{ or } a = r\omega^2$$

Centripetal force

According to Newton's II Law of motion, $F = ma$. As 'm' is the mass of the particle moving along a circular path of radius r,

Centripetal force = mass X normal acceleration.

$$\text{Normal acceleration, } a = \frac{v^2}{r} \quad \text{or} \quad a = r\omega^2$$

$$\text{Centripetal force, } F = \frac{mv^2}{r} \quad \text{or} \quad F = mr\omega^2$$

SOLVED PROBLEMS

1. A ball weighing 0.5 kg is tied to one end of a string and is whirled at a constant speed of 10ms^{-1} in a horizontal plane. If the length of the string is 1m, calculate the normal acceleration and the tension in the string.

Given

$$m = 0.5 \text{ kg}, v = 10\text{ms}^{-1} \quad l = r = 1\text{m} \quad a = ? \quad F = ?$$

$$\text{Normal acceleration } a = \frac{v^2}{r} = \frac{(10)^2}{1} = 100 \text{ ms}^{-2}$$

Tension in the string (Centripetal force)

$$F = \frac{mv^2}{r} = 0.5 \times (10)^2 = 50\text{N}$$

2. A body of mass 1 kg is tied to a string of length 1m revolves in a horizontal circle. If the angular velocity is 3 rad s^{-1} , calculate the centripetal force acting on the body.

Given

$$m = 1 \text{ kg}, l = r = 1 \text{ m}, \omega = 3 \text{ rad s}^{-1}$$

$$\text{Centripetal force } F = mr\omega^2 = 1 \times 1 \times (3)^2 = 9 \text{ N}$$

3. Find the centripetal force on a body of mass 500 g when it revolves in a circle of radius 1.5m. The body makes 120 R.P.M.

Given

$$m = 500 \text{ g} = 0.5 \text{ kg}, r = 1.5\text{m}$$

No. of revolutions = 120 per minute

$$\text{i.e., } n = \frac{120}{60} = 2 \text{ revolutions per second}$$

Centripetal force $F = m r \omega^2$

$$= mr (2\pi n)^2 \quad (\text{since } \omega = 2\pi n) \quad = 4\pi^2 m r n^2$$

$$= 4 \times 3.14 \times 3.14 \times 0.5 \times 1.5 \times 2^2 \quad F = 118.4\text{N}$$

4. A mass of 5kg is moving in a circle of radius 1m. If the centripetal force acting on the mass is 20N, find the linear velocity and angular velocity.

Given

$$F = 20\text{N}, \quad r = 1\text{m}, \quad m = 5 \text{ kg}$$

$$F = \frac{mv^2}{r}$$

$$v^2 = \frac{Fr}{m} = \frac{20 \times 1}{5} = 4$$

$$v = 2 \text{ ms}^{-1}$$

$$\text{Angular velocity, } \omega = \frac{v}{r} = \frac{2}{1} = 2 \text{ rad s}^{-1}$$

5. A rope of length 1m can withstand a maximum weight of 10 kg. Now a stone of mass 200 g is tied to it and is whirled round in a horizontal circle. Calculate the maximum permissible speed of the stone.

Given

$$r = 1\text{m}, \quad m = 200\text{g} = 0.2\text{kg} \text{ and } F = 10 \times 9.8 \text{ N}$$

$$F = \frac{mv^2}{r}$$

$$v^2 = \frac{Fr}{m} \quad \therefore v = \sqrt{\frac{Fr}{m}} = \sqrt{\frac{10 \times 9.8 \times 1}{0.2}}$$

$$v = 7.07 \text{ ms}^{-1}$$

6. One end of a string of length 0.64 m is attached to a bucket containing water and the bucket is rotated about the other end in a vertical circle. Find the minimum speed with which it can be rotated without spilling the water at the highest point. How many revolutions per minute it is making?

Given

$$\text{Length of the string (or) radius of the circle } r = 0.64 \text{ m}$$

For without spilling the water at highest point

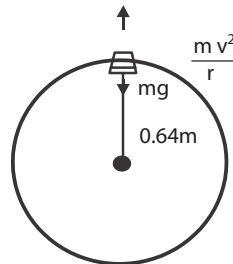

$$mg = \frac{mv^2}{r} \quad (\text{or}) \quad g = \frac{v^2}{r}$$

$$\therefore v^2 = rg = 0.64 \times 9.8 = 6.272$$

$$\therefore \text{The minimum speed } v = \sqrt{6.272} = 2.504 \text{ ms}^{-1}$$

Let n be the no. of revolutions per second.

$$n = \frac{\omega}{2\pi} = \frac{v}{r2\pi} = \frac{2.504}{0.64 \times 2\pi} = 0.6231$$

$$\text{No of revolutions per minute} = 0.6231 \times 60$$

$$= 37.4 \text{ revolutions}$$

Banking of curved paths :

Curved track is to be considered as a part of the circular path. Consider a motor car moving along a curved road. Now two forces are acting on the car, one is the weight of the car acting downward and second is the normal reaction acting upward. In addition to these two forces, a horizontal centripetal force should act on the car for safe negotiation of curved motion. This force is supplied by the pressure exerted by the road on the tyres of the car towards inner side.

According to Newton's third law of motion, the tyres exert an equal and opposite pressure on the road towards the outer side. Hence there must be a frictional force between the road and the tyres. This frictional force tries to balance the centrifugal force. If the road is in horizontal level, the friction may not be sufficient to balance the centrifugal force. Then the car may skid. To avoid this the outer edge of the road is raised a little above the level of the inner edge. This formation is called as banking of curved paths.

In the case of train moving along a curved track, the necessary centrifugal force is supplied by the pressure exerted by the rails on the flanges of the wheels. Also the flanges of the wheels exert an equal and opposite pressure on the rails. Hence there must be a large amount of friction and it leads to damage the rails also to derailment of the train.

To avoid this damage and derailment, the outer rail is suitably raised over the inner rail to eliminate the flange pressure on the rails. This formation is called as banking of curved railway tracks.

The raising of outer edge of a curved path than the inner edge for providing the necessary centripetal force is known as banking of curved path.

Angle of Banking

It is the angle between the normal horizontal path and the curved banked path.

The angle of banking of a curved path is defined as the angle through which the outer edge of the road is raised over the inner edge.

The angle of banking of curved railway tracks is defined as the angle through which the outer rail is raised over the inner rail.

Expression for Angle of banking of Railway tracks

Consider a train moving along a curved path of radius r . In figure, ABCD shows the vertical cross section of a railway carriage. If the outer rail is raised over the inner rail by an angle θ , the carriage is inclined to the horizontal by the same angle. This angle is called angle of banking of the railway tracks.

Let R_1 and R_2 be the reactions of the inner and outer rails.

$$\begin{aligned} \text{The total vertical component of } R_1 \text{ and } R_2 &= R_1 \cos \theta + R_2 \cos \theta \\ &= (R_1 + R_2) \cos \theta \end{aligned}$$

$$\begin{aligned} \text{The total horizontal component of } R_1 \text{ and } R_2 &= R_1 \sin \theta + R_2 \sin \theta \\ &= (R_1 + R_2) \sin \theta \end{aligned}$$

The vertical component balances the downward weight of the carriage. The horizontal component supplies the necessary centripetal force and it balances the centrifugal force. Let m be the mass of the carriage and v be the speed of the train.

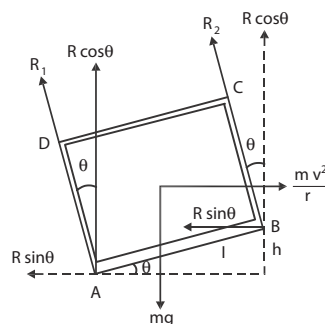

The downward weight = mg

The centrifugal force = $\frac{mv^2}{r}$

Equating the forces $(R_1 + R_2) \cos \theta = mg$ (1)

$$(R_1 + R_2) \sin \theta = \frac{mv^2}{r} \tag{2}$$

$$\frac{(2)}{(1)} \frac{(R_1 + R_2) \sin \theta}{(R_1 + R_2) \cos \theta} = \frac{mv^2}{r m g}$$

$$\text{ie., } \tan \theta = \frac{v^2}{rg}$$

∴ The angle of banking of railway track,

Let 'l' be distance (AB) between the rails. $\theta = \tan^{-1} \left(\frac{v^2}{rg} \right)$

If 'θ' small, $\sin \theta = \tan \theta$

$$\therefore \frac{h}{l} = \frac{v^2}{rg} \quad h = \frac{v^2 l}{rg}$$

While constructing curved railway tracks, the value of h is obtained for fixed values of v, l and r.

Therefore, on a curved rail track, every train has to move with a particular speed specified for the track.

SOLVED PROBLEMS

1. A cyclist is riding at a speed of 22ms^{-1} takes a turn on a curved circular road of radius 44m. What is his inclination to the vertical?

Given

$$V = 22 \text{ ms}^{-1}, r = 44\text{m}, g = 9.8 \text{ ms}^{-2}$$

$$\begin{aligned} \tan \theta &= \frac{v^2}{rg} \\ &= \frac{(22)^2}{44 \times 9.8} = \frac{484}{431.2} \end{aligned}$$

$$\tan \theta = 1.122$$

$$\theta = \tan^{-1}(1.122) = 48^\circ 18'$$

2. An electric train has to travel on a railway track with a curve of radius 120 m with a speed of 36 kmph. Calculate the angle of banking of the rails.

Given

$$v = 36 \text{ kmph} = 36 \times \frac{1000}{3600} = 10\text{ms}^{-1}$$

$$r = 120 \text{ m} \quad g = 9.8 \text{ ms}^{-2}$$

$$\tan \theta = \frac{v^2}{rg} = \frac{(10)^2}{120 \times 9.8}$$

$$\tan \theta = 0.0850$$

$$\theta = \tan^{-1}(0.085) = 4^\circ 51'$$

3. A bend in level road has a radius of 18m. Find the maximum speed with which a car negotiates the bend without skidding. The elevation of the road is 7° .

Given

$$R = 18\text{m}, \quad \theta = 7^\circ \quad \text{and} \quad g = 9.8\text{ms}^{-2}$$

$$\tan \theta = \frac{v^2}{rg}$$

$$v^2 = rg \times \tan \theta = 18 \times 9.8 \times \tan 7^\circ$$

$$= 18 \times 9.8 \times 0.1222 = 21.65$$

$$v = 4.65\text{ms}^{-1}$$

SIMPLE HARMONIC MOTION

Any motion in nature is classified into two types, viz., periodic and non-periodic motion. Periodic motion is that motion which repeats itself after equal intervals of time. The examples of periodic motion are the motion of planets around the sun, motion of hands of a clock, motion of the balance wheel of a watch.

If a body moves back and forth repeatedly about a mean position, it is said to possess oscillatory motion. Vibrations of guitar strings, motion of a pendulum bob, vibrations of a tuning fork oscillations of mass suspended in a spring, vibrations of diaphragm in telephones are few examples of oscillatory motion. In all the cases of vibrations of bodies, the path of vibration is always directed towards the mean or equilibrium position.

The oscillations can be expressed in terms of simple harmonic functions like sine or cosine function. A harmonic oscillation of constant amplitude and single frequency is called simple harmonic motion (SHM).

A particle is said to execute simple harmonic motion if its acceleration is directly proportional to the displacement from a fixed point and is always directed towards that point.

Important definitions of SHM Displacement

The distance travelled by the oscillating particle from its mean position at any instant is called displacement.

Amplitude

The maximum displacement of the oscillating particle from its mean position is called amplitude.

Oscillation

One complete to and fro motion is called one oscillation.

Period

Time taken by the oscillating particle to complete one oscillation is called period.

Frequency

The number of oscillations or vibrations made by the vibrating particle in one second is called frequency.

QUESTIONS

PART – A and PART – B

1. What is a projectile?
2. Define velocity of projection.
3. Define angle of projection.
4. Define trajectory of a projectile.
5. Define maximum height of a projectile.
6. Define time of flight of a projectile.
7. Define range of a projectile.
8. Give the condition for maximum range of a projectile.
9. What is a circular motion?
10. Define radian.
11. Define angular velocity.
12. Define normal acceleration.
13. Define centripetal force.
14. What is centrifugal force?
15. Define angle of banking.
16. Why does the outer rail is raised over the inner rail along a curved railway track?
17. Define Simple Harmonic Motion
18. Define amplitude
19. Define frequency
20. Define period
21. Define Newton's Law of motion
22. Explain fundamental equation of motion
23. What are the condition for maximum range
24. Derive the relation between angular velocity and linear velocity
25. Explain centripetal force and centrifugal force
26. Explain the banking of curved path

PART C

1. Derive an expression for the time of flight of the projectile.
2. Derive an expression for the horizontal range of the projectile.
3. Show that the range is maximum when the angle of projection is 45° for a given velocity of projection.
4. Prove that the path of a projectile is a parabola.
5. Derive the relations between angular velocity, period and frequency.
6. Obtain expressions for the normal acceleration and centripetal force of a body executing uniform circular motion.
7. Derive an expression for the angle of banking.

Exercise problems

1. A particle is thrown at an angle of 30° with a velocity of 36 kmph Calculate its (1) time of flight and (2) horizontal range.

Ans: (i) 1.02s, (ii) 8.84m

2. The range of a projectile is equal to 3 times the maximum height attained. Find the angle of projection.

Ans: $53^\circ 7'$

3. The maximum height of a projectile is 2 times its horizontal range reached. Find the angle of projection.

Ans: $79^\circ 58'$

4. A bomber flying horizontally with a constant velocity of 600 kmph at a height 480m wants to hit a target on the ground. Find at what horizontal distance from the target should a bomb be dropped in order to hit the target.

Ans: $R = 1648 \text{ m}$

5. A body of mass 2 kg tied to a string of length 2m revolves in a horizontal circle. If the angular velocity of the body is 5 rad s^{-1} , calculate the centripetal force acting on the body.

Ans: $F = 100\text{N}$

6. In a circus, a man is riding a motor cycle in the form of vertical circle inside the hollow spherical cave of diameter 6m. Find the minimum speed of the rider with which he can be riding without falling at the highest point.

Ans: $v = 7.668\text{ms}^{-1}$ or 27.6 kmph

7. A string of length 1.5 m can withstand a maximum weight of 5kg.wt. A body of mass 2kg is tied to it and whirled round in a horizontal plane. Calculate the possible maximum number of revolutions per minute

Ans : $\text{RPM} = 38.6$

8. A scooter rider negotiates a curve of 100m radius on a level road with a speed of 72 kmph. Calculate the angle of inclination to the vertical he should make to avoid falling.

Ans: $\theta = 22^\circ 12'$

9. An electric train has to travel a curved railway line of radius 50m with maximum speed of 36 kmph. Calculate the angle through which the outer rail should be raised so that there is no lateral thrust on the rails.

Ans: $= 11^\circ 31'$

10. An aeroplane with a speed of 120 ms^{-1} negotiates a curve of radius 1200m. Calculate its angle of banking.

Ans: $= 50^\circ 45'$

11. The expected average speed of the traffic on a high way around the curve is 20 kmph. Calculate the angle of banking of the high way if its radius of curvature be 12m.

Ans: $= 14^\circ 42'$

Brain teaser

1. An electric train has to travel on a railway track with a bend of radius 120m with a speed of 45 kmph. Calculate the height through which the outer rail should be raised for safe running of the train, if the distance between the two rails is 1.6m.

4.1 ROTATIONAL MOTION OF RIGID BODIES

Introduction:

According to Newton's first law of motion, "Every body continues to be in a state of rest or in a state of uniform motion along a straight line, unless it is compelled to change that state by some external force".

This law consists of two parts i.e., (1) A body at rest will not move on its own unless an external force acts on it and (2) A body which is in uniform linear motion will not change either its speed or direction of motion on its own, without the help of an external force.

The inability of a body to change its state on its own, without the help of external force is termed as inertia. Inertia is a fundamental property of the matter. The more is the mass of the body, the more will be inertia. Thus in translatory (linear) motion the mass of the body is a measure of coefficient of inertia.

Rigid body

If the distance between any two points in a body is not altered by applying a force, however large the force may be, the body is said to be a rigid body.

A rigid body may be defined as that body which does not undergo any change in its shape or size due to the application of force.

Actually, no body is a perfect rigid body. When the changes in the body are negligible, it can be considered as a rigid body.

Rotational motion

Each body is made of large number of tiny particles. In the case of linear motion, all the particles present in the body will have same linear velocity.

When the body rotates about a fixed line (axis of rotation), its motion is known as rotatory motion.

The axis of rotation may lie within the body or outside the body. If all the particles of a body move in a circular path about the axis of rotation, the rigid body is said to have pure rotational motion.

When a body is in rotational motion about an axis, all the particles present in the body will have same angular velocity, but different linear velocities. The values of the linear velocities of these particles depend on the distance of the particles from the axis of rotation, since $v = r \omega$

In rotational motion also, a rigid body which is free to rotate about an axis, opposes the change to be produced in its state. The measure of opposition not only depends on the mass of the body but also on the distances of the particles of the body from the axis of rotation.

Suppose a particle of mass 'm' is at a distance r from an axis, the product mr^2 is called the moment of inertia of the particle about that axis.

Thus in rotational motion the moment of inertia of the body about the given axis of rotation is a measure of coefficient of inertia.

Hence, the moment of inertia plays the same role in rotational motion as that of mass in translatory motion.

Moment of Inertia of a particle

The moment of inertia of a particle about an axis is equal to the product of the mass of the particle and square of its distance from the axis.

Consider a particle of mass 'm' is placed at a distance 'r' from the fixed axis. Then, the moment of inertia of the particle about the axis = mr^2 . The S.I. unit for moment of inertia is kg m^2 .

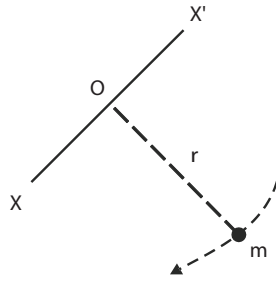

Moment of Inertia of a rigid body

Inertia of a body is its inability to change by itself its state of rest or of uniform motion in a straight line.

Similarly Moment of inertia of a body is its inability to change by itself its state of rest or of uniform rotatory motion about an axis.

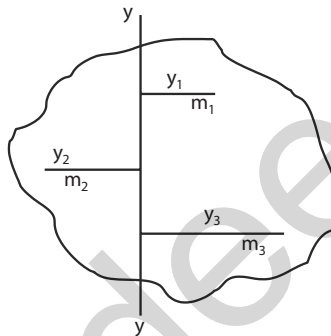

An external torque (rotating effect of force) is necessary to change its state.

Let us consider the rotation of a rigid body about an axis. It consists of a large number of particles of masses m_1, m_2, m_3 etc., situated at distances r_1, r_2, r_3 etc., from the axis 'yy'. Then $m_1 r_1^2$ is known as the moment of inertia of the particle of mass m_1 about that fixed axis.

Then, the moment of inertia of the rigid body = Sum of moments of inertia of all the particles present in the body.

$$I = m_1 r_1^2 + m_2 r_2^2 + m_3 r_3^2 + \dots$$

$$I = \Sigma mr^2$$

Hence the moment of inertia of a rigid body about a fixed axis is the sum of the moment of inertia of all the particles of the rigid body.

Radius of gyration

Radius of gyration is the distance between the given axis and the centre of mass of the body. The centre of mass of a body is point where the entire mass of the body is supposed to be concentrated.

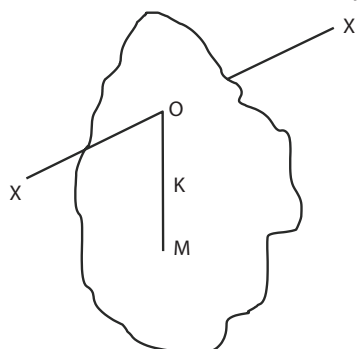

It is denoted by ' K '.

If M is mass of the body, then moment of inertia $I = MK^2$.

Hence, $mr^2 = MK^2$

Expression for Kinetic Energy of a Rigid body rotating about an axis:

Consider a rigid body rotating about a fixed axis XOX' . The rigid body consists of a large number of particles. Let m_1, m_2, m_3, \dots etc., be the masses of the particles situated at distances r_1, r_2, r_3, \dots etc., from the fixed axis. All the particles rotate with the same angular velocity ω . But the linear velocities of the particles are different.

$$\begin{aligned} \text{Kinetic Energy} &= \frac{1}{2} mv^2 \\ &= \frac{1}{2} m (r\omega)^2 && (\because v = r\omega) \\ &= \frac{1}{2} m r^2 \omega^2 \end{aligned}$$

The kinetic energy of the first particle $= \frac{1}{2} m_1 r_1^2 \omega^2$

The kinetic energy of the second particle $= \frac{1}{2} m_2 r_2^2 \omega^2$

The kinetic energy of the third particle and so on $= \frac{1}{2} m_3 r_3^2 \omega^2$

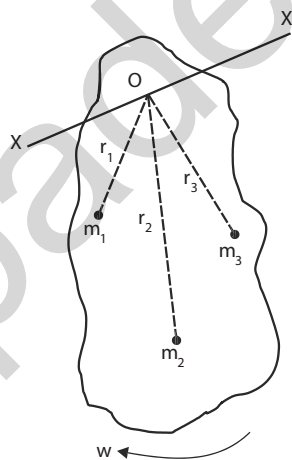

The kinetic energy of the whole body is equal to the sum of the kinetic energy of all the particles present in the body.

$$\begin{aligned} \text{The kinetic energy of the rigid body} &= \frac{1}{2} m_1 r_1^2 \omega^2 + \frac{1}{2} m_2 r_2^2 \omega^2 + \frac{1}{2} m_3 r_3^2 \omega^2 + \dots \\ &= \left(\frac{1}{2} m_1 r_1^2 + m_2 r_2^2 + m_3 r_3^2 + \dots \right) \omega^2 \\ &= \frac{1}{2} \sum mr^2 \omega^2 \end{aligned}$$

But, $\sum mr^2 =$ Moment of inertia of the rigid body about the fixed axis $= I$

Therefore, The kinetic energy of the rigid body $= \frac{1}{2} I \omega^2$

Angular momentum

The moment of linear momentum is known as angular momentum.

Consider a particle of mass m is at a distance r from the axis of rotation. When a particle is in rotational motion about an axis, it has both linear velocity ' v ' and angular velocity ' ω '.

Then, Angular momentum of the particle = linear momentum \times perpendicular distance between the particle and the axis of rotation

$$= m v \times r$$

$$= m r \omega \times r \quad (\because v = r\omega)$$

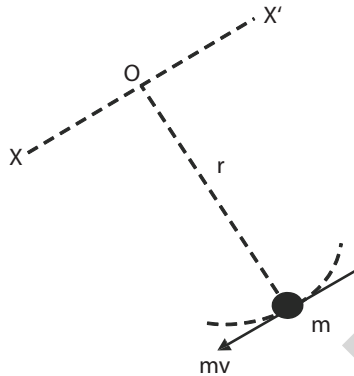

$$\therefore \text{Angular momentum} = mr^2\omega$$

Where ω is the angular velocity of the particle.

The SI unit for angular momentum is $\text{kg m}^2 \text{s}^{-1}$

Expression for Angular momentum of a Rigid body rotating about an axis:

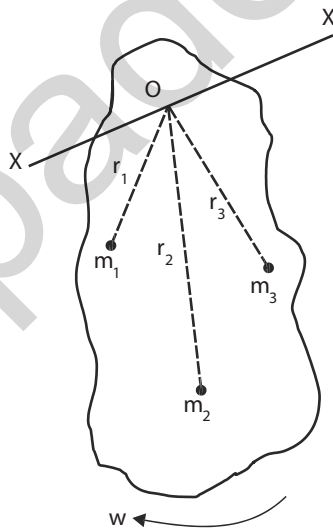

Consider a rigid body rotating about a fixed axis XOX' . The rigid body consists of a large number of particles. Let m_1, m_2, m_3, \dots etc., be the masses of the particles situated at distances r_1, r_2, r_3, \dots etc., from the fixed axis. All the particles rotate with the same angular velocity, but with different linear velocities depending on the values of ' r '.

$$\begin{aligned} \text{Angular momentum} &= \text{moment of linear momentum} \\ &= \text{linear momentum} \times \text{distance} \\ &= mv \times r = mr\omega \times r \quad (\because v = r\omega) \\ &= mr^2\omega \end{aligned}$$

- ∴ The angular momentum of the first particle = $m_1 r_1^2 \omega$
 The angular momentum of the second particle = $m_2 r_2^2 \omega$
 The angular momentum of the third particle = $m_3 r_3^2 \omega$
 ...and so on.

The angular momentum of the whole body is equal to the sum of the angular momenta of all the particles present in the body.

$$\left. \begin{array}{l} \text{The angular momentum} \\ \text{of the rigid body} \end{array} \right\} L = m_1 r_1^2 \omega + m_2 r_2^2 \omega + m_3 r_3^2 \omega + \dots$$

$$= (m_1 r_1^2 + m_2 r_2^2 + m_3 r_3^2 + \dots) \omega$$

$$= \Sigma m r^2 \omega$$

But, $\Sigma m r^2 =$ moment of inertia of the rigid body = I

∴ The angular momentum of the rigid body = $I\omega$

Law of conservation of angular momentum

When there is no external torque acting on a rotating body, the angular momentum of that body remains a constant. This is the statement of law of conservation of angular momentum.

i.e., if I_1 and ω_1 are the initial moment of inertia and angular velocity of a rotating body and if I_2 and ω_2 are new moment of inertia and angular velocity of the body, without the help of any external torque, then according to this law,

$$I_1 \omega_1 = I_2 \omega_2$$

Examples

- Consider a person standing on a turn-table with arms extended and a pair of weights, one in each hand. The table is made to rotate by a motor and then the motor is switched off. Now, if that person pulls his arms inwards, we can see a considerable increase in the speed of rotation. This is because, in the new position, his moment of inertia I about the axis of rotation decrease, due to the decrease in the value of r . Since the angular momentum is conserved, a decrease in the value I results in an increase in the value of angular velocity ω . Therefore the person is found to rotate faster.
- A circus acrobat, a diver or skater, all take advantage of this principle. consider a diver has just left a diving board with his arms and legs extended, with a particular angular momentum. If he now pulls his arms and legs in, his moment of inertia I decreases, leading to increase in angular velocity ω . By increasing ω , the diver can perform more number of somersaults, before entering the swimming pool.

4.2 GRAVITATION

Newton's laws of Gravitation

Law 1 : Any two particles of matter attract each other with a force

Law 2 : The force of attraction between any two objects is

- i. directly proportional to the product of the masses
- ii. inversely proportional to the square of the distance between them.

If m_1, m_2 are masses of two particles, separated by a distance 'd' then the force of attraction between the particles,

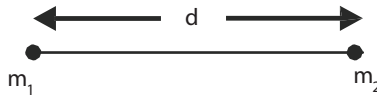

$$F \propto \frac{m_1 m_2}{d^2}$$

$$F = G \frac{m_1 m_2}{d^2}$$

where G is known as “universal gravitational constant” and the value of $G = 6.6733 \times 10^{-11} \text{ N m}^2\text{kg}^{-2}$

Acceleration due to gravity

Galileo was the first to make a systematic study of the motion of a body under the gravity of Earth. He dropped various objects from the leaning tower of Pisa and made analysis of their motion under gravity. He came to the conclusion that “in the absence of air, all bodies will fall at the same rate”. It is the air resistance that slows down a piece of paper or a parachute falling under gravity. If a heavy stone and a parachute are dropped where there is no air, both will fall together at the same rate.

Experiments showed that the velocity of a freely falling body under gravity increases at a constant rate. i.e., with a constant acceleration. The acceleration produced in a body on account of the force of gravity is called acceleration due to gravity. It is denoted by ‘g’. At a given place, the value of ‘g’ is the same for all bodies irrespective of their masses. It differs from place to place on the surface of the Earth. It also varies with altitude and depth.

The value of g at sea-level and at a latitude of 45° is taken as the standard (i.e) $g = 9.81 \text{ m s}^{-2}$.

Acceleration due to gravity at the surface of the Earth

Consider a body of mass m on the surface of the Earth as shown in the Figure. Its distance from the centre of the Earth is R (radius of the Earth).

The gravitational force experienced by the body, $F = \frac{GMm}{R^2}$

where M is the mass of the Earth.

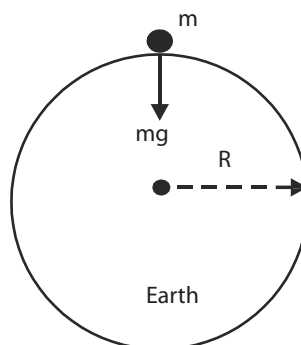

From Newton's second law of motion,

Force $F = mg$.

$$\text{Equating the above two forces, } \frac{GMm}{R^2} = mg$$

$$\therefore g = \frac{GM}{R^2}$$

This equation shows that g is independent of the mass of the body m . But, it varies with the distance from the centre of the Earth. If the Earth is assumed to be a sphere of radius R , the value of g on the surface of the Earth is given by

$$\text{Mass and Weight } g = \frac{GM}{R^2}$$

Variation of acceleration due to gravity with altitude (height):

Let P be a point on the surface of the Earth and Q be a point at an altitude h . Let the mass of the Earth be M and radius of the Earth be R . Consider the Earth as a spherical shaped body.

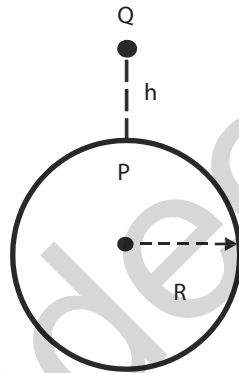

The acceleration due to gravity at P on the surface is

$$g = \frac{GM}{R^2} \quad \text{-----} \rightarrow (1)$$

Let the body be placed at Q at a height h from the surface of the Earth. The acceleration due to gravity at Q is

$$g_h = \frac{GM}{(R+h)^2} \quad \text{-----} \rightarrow (2)$$

dividing (2) by (1) $\frac{g_h}{g} = \frac{R^2}{(R+h)^2}$

By simplifying and expanding using binomial theorem, $g_h = g \left(1 - \frac{2h}{R}\right)$

The value of acceleration due to gravity decreases with increase in height above the surface of the Earth.

4.3 SATELLITES

A body moving in an orbit around another bigger body is called a satellite. A body that moves around a planet is called a satellite.

The objects that are moving in orbit by nature itself around a planet are called natural satellites. For example, moon is the natural satellite for the earth. The earth is a satellite for the sun. Man also has placed artificially some satellites to move in orbit around the desired planets. These satellites are called artificial satellite.

The artificial satellites are carried by rockets to the predetermined height, a few hundred kilometers above the surface of the earth. At this height the air is in a rarefied state and hence air friction is negligible.

After reaching the predetermined height, the satellite is given very high horizontal velocity so that it remains moving in a nearly circular orbit.

The artificial satellites are broadly classified as earth resources satellites, meteorological satellites and satellites carrying microwave sensors.

Escape velocity and Orbital velocity

Escape velocity (V_e)

When a body is thrown vertically upwards, it will return to the earth's surface after attaining certain height. If the velocity of projection is increased, the height attained by the body becomes greater and then the body returns to the earth. This is due to the gravitational force of attraction of the earth. If the body is to be projected with a particular greater velocity, the body escapes from the gravitational pull so that it never returns to the earth. This velocity of projection is called escape velocity, it is different for different planets.

The minimum velocity required to project a body in upward direction from the surface of the earth so that it escapes from the earth's gravitational pull is called escape velocity.

Orbital velocity (V_o)

In order to put a satellite into the orbit around the earth, the satellite must be projected to the particular height and then it must be turned in a direction perpendicular to the line from the centre of the earth so that it moves in an orbit around the earth.

The velocity of the satellite along its orbit around the earth is called orbital velocity.

Expression for Escape Velocity (V_e) :

Consider a body of mass m which is to be projected with escape velocity V_e from the surface of the earth. If the body is placed on the surface of the earth, then

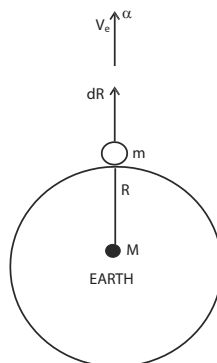

$$\text{The weight of the body} = mg \quad \dots(1)$$

Let M be the mass of the earth and R its radius. According to Newton's law of gravitation,

$$\text{The gravitational force, } F = \frac{GMm}{R^2} \quad \dots(2)$$

where G is a constant known as gravitational constant. The gravitational force on a body in the earth's atmosphere is also equal to the weight of the body. Equating the eqns. (1) and (2)

$$\frac{GMm}{R^2} = mg$$

$$GM = gR^2$$

Since V_e is the escape velocity given to the body.

$$\text{The given kinetic energy} = \frac{1}{2} mV_0^2 \quad \dots(3)$$

This kinetic energy is converted into workdone to escape the body from gravitational pull.

If the body moves a distance dR in vertical direction against the force F , then,
Work = Force \times distance

$$\begin{aligned} \therefore \text{Work done by the body} &= F \, dR \\ &= \frac{GMm}{R^2} \times dR \end{aligned}$$

In order to escape the body from the gravitational pull, the work done by the body to move from the distance R to infinity (the boundary of the gravitational field) is given by

$$W = \int_R^\infty \frac{GMm}{R^2} \, dR$$

$$\begin{aligned} W &= \frac{GMm}{R} \\ \frac{1}{2} m V_0^2 &= \frac{GMm}{R} \end{aligned}$$

Equating the eqns. (3) and (4).

$$V_e = \sqrt{\frac{2GM}{R}}$$

$$\text{Here, } GM = gR^2$$

$$\therefore V_e = \sqrt{\frac{2gR^2}{R}}$$

$$\therefore \text{The Escape velocity } V_e = \sqrt{2gR}$$

Expression for orbital velocity of a satellite :

Consider a satellite of mass m is placed on the surface of the earth.

$$\text{The weight of the satellite} = mg \quad \dots\dots (1)$$

Let M be the mass of the earth, and R its radius. According to Newton's law of gravitation,

$$\text{The gravitational force } F = \frac{GMm}{R^2} \quad (2)$$

where G is a constant known as gravitational constant.

The gravitational force on the satellite is equal to its weight. Equating the eqns. (1) and (2).

$$\frac{GMm}{R^2} = mg \quad \therefore GM = gR^2$$

The satellite is to be projected vertically upto a particular height h , after it must be turned in a perpendicular direction, then the satellite revolves around the earth in a circular orbit of radius r , with an orbital velocity of V_0 .

The centripetal force, $F = \frac{mV_o^2}{r}$... (3)

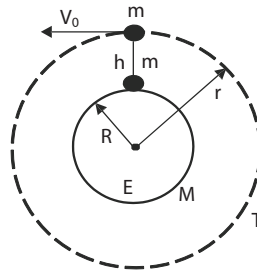

The necessary centripetal force for circular motion of the satellite is given by the gravitational force. Hence, equating the equations (3) and (2)

$$\frac{mV_o^2}{r} = \frac{GMm}{r^2}$$

$$\therefore V_o = \sqrt{\frac{GM}{r}} = \sqrt{\frac{gR^2}{r}} \quad (\because GM = gR^2)$$

The orbital velocity of the satellite, $V_o = \sqrt{\frac{gR^2}{R+h}}$ ($\because r = R + h$)

Note: When the satellite is launched in near earth orbit which is 200 km to 300 km, h is small when compared to R so that, $R + h = R$. Then

$$V_o = \sqrt{gR}$$

Uses of Artificial Satellites

The artificial satellites are launched for many purposes by different countries. The important uses of artificial satellite are

- i) Collection of scientific data
- ii) Weather monitoring
- iii) Military Spying
- iv) Remote sensing
- v) Communication purpose – the satellite receives microwaves and TV signals from the earth and amplifies them and transmits them back to various stations on the earth.

WORKED PROBLEMS

1. If the radius of the earth is 6400km and the acceleration due to gravity is 9.8ms^{-2} . Calculate the escape velocity

Given: $R = 6400 \text{ km}$ and $g = 9.8 \text{ ms}^{-2}$

$$\text{Escape velocity } V_o = \sqrt{2gR} = \sqrt{2 \times 9.8 \times 6400 \times 10^3}$$

$$V_o = 11.2 \text{ km per second}$$

2. A satellite is revolving round the earth at a distance of 182 km from the surface of the earth. The radius of the earth is 6371 km and g is 9.81 ms^{-2} . Calculate the orbital velocity of the satellite.

Given: $g = 9.81 \text{ ms}^{-2}$, $R = 6371 \times 10^3 \text{ m}$, $h = 182 \times 10^3 \text{ m}$
 $(R+h) = (6371 + 182) 10^3 = 6553 \times 10^3 \text{ m}$

$$V_o = \frac{gR^2}{(R+h)} = \sqrt{\frac{9.81 \times (6371 \times 10^3)^2}{6553 \times 10^3}}$$

$$V_o = 7795 \text{ ms}^{-1} \text{ (or) } 7.795 \text{ kms}^{-1}$$

QUESTIONS**Part – A and B**

1. Define rigid body
2. Define moment of inertia of a particle
3. Define moment of inertia of a rigid body
4. Define radius of gyration
5. Define angular momentum
6. State the law of conservation of angular momentum
7. State Newton's I law of gravitation
8. State Newton's II Law of gravitation
9. What is a satellite?
10. Define escape velocity
11. Define orbital velocity
12. Give any two uses of artificial satellites
13. Derive an expression for the moment of inertia of a rigid body about an axis.
14. Explain Newton's Law of Gravitation
15. Explain escape velocity and orbital velocity
16. Write the uses of artificial satellites

Part – C

1. Derive an expression for the kinetic energy of a rigid body rotating about an axis.
2. Derive an expression for the angular momentum of a rigid body rotating about an axis.
3. Obtain an expression for the acceleration due to gravity on the surface of the earth.
4. Obtain an expression for the variation of acceleration due to gravity with altitude.
5. Derive an expression for the escape velocity from the surface of the earth
6. Derive an expression for the orbital velocity of a satellite.

Exercise Problems

1. Find the escape velocity at the surface of the moon, given that the radius of moon is 2×10^6 m and acceleration due to gravity on the surface of moon is 1.69 ms^{-2} .
2. A satellite is revolving in circular orbit at a height of 800 km from the surface of the earth. Calculate the orbital velocity. The radius of the earth is 6400 km and $g = 9.8 \text{ ms}^{-2}$

Brain teaser

1. The escape velocity from the surface of the earth is 11.2 kms^{-1} . Find the escape velocity from the surface of another planet where mass and diameter are twice that of earth.
2. What is the acceleration due to gravity at a distance from the centre of the Earth, which is equal to diameter of the Earth ?

UNIT 5

SOUND AND MAGNETISM

5.1 SOUND

Introduction:

Sound is produced due to the vibrations of the body. These vibrations are transferred to the air medium and propagated in all directions in the form of waves. When the vibrational sound waves reach our ear, the diaphragm of the ear vibrates with equal vibrations produced by the body. Hence we are able to hear the sound by the sensation perceived by the nerves of the ear.

The number of vibrations made in one second is known as frequency of the sound. It is expressed in hertz (Hz). The range of the frequency between 20 Hz and 20,000 Hz is the audible range, Human ears cannot respond to the sound below and above this range. In this sense, all vibrating bodies cannot produce audible sound. The vibrations of frequency below 20 Hz are called infrasonic and above 20,000 Hz are called ultrasonic.

Sound is a mechanical wave and hence it requires a medium to propagate. So we can't hear the sound in vacuum. It travels with the velocity of 330 ms^{-1} in air. Sound waves are reflected and refracted like light waves.

Wave motion:

When a stone is thrown on a pond of water, ripples spread out in all directions on the surface of water. The stone disturbs the water medium at one place but the disturbance is transferred in all directions continuously. This continuous movement of the disturbance is called a wave.

If a wave passes in a medium, the particles of the medium vibrate about their mean position. The particles do not move along with the wave, only the vibrations are transferred from one particle to adjacent particle of the medium in the form of energy.

There are two types of wave motion. They are

- 1) Longitudinal wave motion and
- 2) Transverse wave motion

1) Longitudinal wave motion:

If the particles of the medium vibrate parallel to the direction of propagation of the wave, the wave is known as longitudinal wave.

Examples:

1. The propagation of sound in air
2. The propagation of sound in gas
3. The propagation of sound inside the liquid

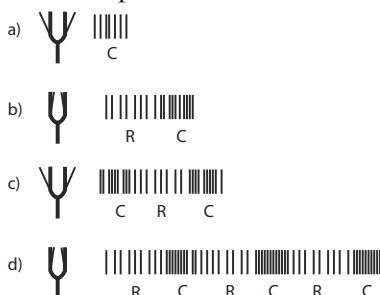

The longitudinal waves travel in a medium in the form of compressions and rarefactions. The place where the particles of the medium crowded together are called compressions and the places where the particles spread out are called rarefactions.

The compressions and rarefactions produced by a vibrating tuning fork are as shown in the figure. When the prong (arm) of the fork moves to the right, it compresses the medium in front of it to form compression. Meanwhile the prong returns to the left, a temporarily vacuum is created there. To fill it, the particles of the medium spread out in that place to form a rarefaction.

Thus as the prong of the fork vibrates to and fro, alternate compressions and rarefactions are transmitted in the medium. As a result, the particles of the medium simply move back and forth about their mean position parallel to the direction of the propagation of the wave.

2) Transverse wave motion:

If the particles of the medium vibrate perpendicular to the direction of propagation of the wave, the wave is known as transverse wave.

Examples :

1. Ripples travelling on the water surfaces.
2. Waves travelling along a rope.
3. Other waves like light waves, heat radiations, radio waves etc.

The transverse waves travel in a medium in the form of crests and troughs. The points where the particles of the medium displaced maximum in the upward direction are called crests. The points where the particles displaced maximum in the downward direction are called troughs.

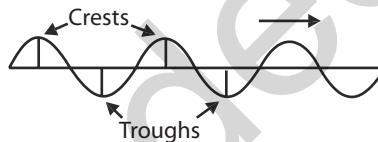

The crests and troughs produced by the transverse wave motion are as shown in the figure. In transverse wave, alternate crests and troughs are transmitted in the medium. As a result, the particles of the medium move up and down about their mean position perpendicular to the direction of propagation of the wave.

Progressive Waves:

If a wave travels continuously in a medium without any disturbance, then the wave is said to be progressive wave. Longitudinal waves and Transverse waves are two types of progressive waves and they can travel continuously in any medium if there is no obstruction.

Amplitude:

When sound wave propagates in a medium, the maximum displacement of the vibrating particles of the medium from their mean position is called amplitude.

Wavelength (λ) :

The wavelength is the distance between two consecutive particles of the medium which are in the same state of vibration.

It is also defined as the distance travelled by the wave during the time the vibrating particle completes one vibration.

In longitudinal waves, the wavelength is the distance between two successive compressions or rarefactions. In transverse waves, the wavelength is the distance between two successive crests or troughs.

Period (T):

The time taken by the vibrating particle to make one vibration is called period.

Frequency (n):

The frequency is the number of vibrations made by the vibrating particle in one second.

Velocity (v):

The distance travelled by the sound wave in one second is known as velocity of sound.

Relation between Wavelength, Frequency and Velocity of a Wave :

Let n be the number of vibrations made by the vibrating particle in one second. It is also known as its frequency.

Time taken for one vibration = period (T) = $1/n$.

Let λ be the wavelength of the wave produced

Velocity of the wave is the distance through which the wave advances in the medium in one second

$$\therefore \text{Velocity of wave motion, } V = \frac{\text{distance travelled}}{\text{time taken}}$$

$$V = \lambda/T = \lambda/(1/n) = \lambda n$$

$$\therefore V = n\lambda$$

Stationary Waves:

If a progressive wave travelling in a medium meets the surface of an obstacle, it is reflected. The reflected wave is superimposed on the incident wave to form a new type of wave called stationary wave.

Also, when two identical waves having equal wavelength and amplitude travel in opposite directions they superimpose on each other forming stationary wave.

A stationary wave formed by a vibrating string is as shown in the figure. Consider a string PQ fixed at the end Q and it vibrates up and down at the free end P . Then a transverse wave is setup and it proceeds towards the fixed point Q and gets reflected back to the end P . Now the stationary wave is formed in the string.

At certain points of the medium, the displacement due to the two waves cancel each other and those points remain at rest. Such points are called nodes (N). At certain other points there is maximum displacement. Such points are called antinodes (A). The distance between two successive nodes or antinodes is $\lambda / 2$.

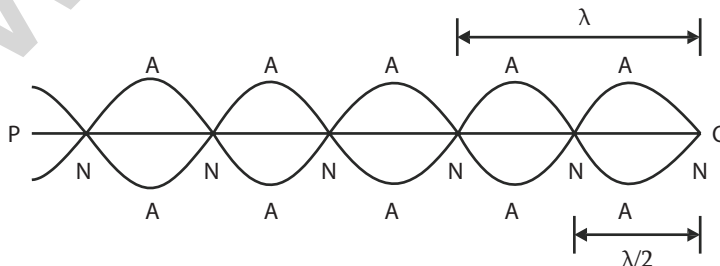

The distance between a node and the next antinode is $\lambda / 4$

The longitudinal waves also produce the stationary waves.

VIBRATIONS**Free Vibrations :**

The vibrations of any body with its natural frequency are called free vibrations.

When a body is set in vibration and left free, it executes vibrations. The frequency depends upon the dimensions and elastic constants of the body. Such vibrations are called free vibrations and the frequency of vibration is known as the natural frequency.

If a tuning fork is set in vibration, it vibrates with its own frequency. Such vibrations are called free vibrations or natural frequency.

Forced Vibrations :

The vibrations of a body with a frequency induces vibrations on another vibrating agent are called forced vibrations.

Suppose a vibrating tuning fork is placed with its stem on a table, the vibrations of the fork are impressed on the table and the table is forced to vibrate. The vibrations set up on the table are called forced vibrations.

Resonance :

When the forced vibrations given on the body is equal to its natural frequency of vibrations, the body vibrates with maximum amplitude. This phenomenon is called resonance.

When a vibrating tuning fork is kept on a table, the table is forced to vibrate with the frequency of the tuning fork. If the natural frequency of the table is equal to the frequency of the tuning fork, the table vibrates with its natural frequency and hence resonance occurs.

Laws of vibration in stretched strings:

I Law : The frequency of vibrating string is inversely proportional to its length, when the tension and linear density of the string are kept constant.

$$n \propto \frac{1}{l}$$

II Law : The frequency of vibration is directly proportional to the square root of the tension, when the length and linear density of the string are kept constant.

$$n \propto \sqrt{T}$$

III Law : The frequency of vibration is inversely proportional to the square root of the linear density of the string, when the tension and length of the string are kept constant.

$$n \propto \frac{1}{\sqrt{m}}$$

According to above laws,

$$n \propto \frac{1}{l} \sqrt{\frac{T}{m}} \quad (\text{or}) \quad n = k \frac{1}{l} \sqrt{\frac{T}{m}}$$

Where k – is a constant and its value is equal to $\frac{1}{2}$.

$$\therefore n \propto \frac{1}{2l} \sqrt{\frac{T}{m}}$$

$$\text{If } (\because T = Mg) = \frac{1}{2l} \sqrt{\frac{Mg}{m}}$$

$$n = \frac{1}{2} \sqrt{\left(\frac{M}{l^2}\right) \frac{g}{m}}$$

Note: The linear density,

$$m = \frac{\text{mass}}{\text{length}} = \frac{\text{Volume} \times \text{density}}{\text{length}} = \frac{\pi r^2 l \rho}{l} = \pi r^2 \rho$$

Sonometer :

The phenomenon of resonance is used in sonometer. In sonometer, the frequency of a tuning fork is equal to the frequency of the vibrating string. Here resonance takes place and the string vibrates with maximum amplitude.

Experimental determination of frequency of a tuning fork using sonometer:

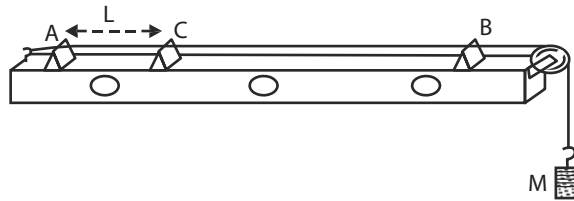

The sonometer consists of a hollow wooden box. A nail is fixed at one end and a smooth pulley is fixed at the other end of the box. One end of a sonometer string is tied to the nail and other end of the string passes over the smooth pulley. The free end is attached to the weight hanger. A, B and C are three knife edges placed on the box under the string. A, B are fixed and C is movable.

A suitable tension ($T = Mg$) is applied to the string. A small paper rider is placed on the string in between A and C. The tuning fork of frequency 'n' is excited with a rubber hammer and its stem is kept on the sonometer box. Now the string is made to vibrate. The movable knife-edge C is adjusted such that the string vibrates with the same frequency of the fork. At that time, the paper rider placed on the string between A and C, is violently thrown off from the string. Now the vibrating length of the string $AC = l$ is measured.

Let r be the radius of the string measured by using screw gauge and ' ρ ' be the density of the material of the wire, then

$$\text{The linear density, } m = \pi r^2 \rho$$

The experiment is repeated by changing the value of tension (load). The readings are tabulated.

Sl.No.	Load (M)	Vibrating length $AC = l$	l^2	$\frac{M}{l^2}$

Mean :

$$\text{The frequency of the tuning fork, } n = \frac{1}{2} \sqrt{\left(\frac{M}{l^2}\right) \frac{g}{m}}$$

The mean value of $\frac{M}{l^2}$ is substituted in the above formula and the frequency of the tuning fork 'n' is calculated

ACOUSTICS OF BUILDINGS:

Echo : The first reflected sound is known as echo. The sound produced by a source is propagated continuously in a medium if there is no disturbance. But if it meets the hard surface of an obstacle, it is reflected. The clear echo depends upon the following factors.

1. Good reflector of sound
2. Maximum surface area of the reflector and
3. The distance of the reflector from the source of sound.

Reverberation :

The sound produced in a hall suffers multiple reflections before it becomes inaudible. As a result of these reflections, the listener continues to receive sound, even if the source of sound is cut off. This prolonged reflection of sound in a room even after the sound source has been stopped is called reverberation. It is the persistence of sound due to multiple reflections from the walls, floor and ceiling of a hall. The reverberation is also called multiple echoes. In a room, the walls, floor and other flat surfaces reflect sound with a small loss of energy.

Reverberation time:

If a building is to be acoustically correct, its reverberation time must be in optimum level. It should not be too long or too short. If it is too short, then the room becomes dead in sound aspect. If it is too long, then the reverberation will be there inside the building for long duration. The reverberation produces continuous sound with decreasing intensity upto a particular time after that it disappears. This time is known as reverberation time.

The reverberation time is defined as the time taken by the sound to fall from its original intensity to one millionth of its original intensity.

Sabine formula :

Sabine derived an equation for the reverberation time.

Where V is the volume of the hall, α is the coefficient of absorption of each reflecting surface present in the hall and A is the area of the each

$$T = \frac{0.16 V}{\alpha A} \text{ second}$$

sound absorbing surface present in the hall.

Coefficient of absorption of sound energy:

The co-efficient of absorption of sound energy of any surface is defined as the ratio of the sound energy absorbed by the surface to the total sound energy incident on the surface.

Let α be the coefficient of absorption of sound energy of a surface, then

$$\alpha = \frac{\text{The sound energy absorbed by the surface}}{\text{The total sound energy incident on the surface}}$$

Acoustics of Buildings (Architectural acoustics):

The term 'Acoustics of building' describe the production, transmission and reception of sound inside the building. The following points should be taken into consideration for the acoustic design of the buildings, auditorium, cinema theatres etc.

1. The sound heard by the audience should be sufficiently loud in any part of the hall.
2. The quality of the speech and music should not be changed anywhere inside the hall.
3. There should not be focusing of sound due to walls and ceiling, in any part of the hall.
4. There should not be any vibrations due to resonance.
5. There should not be any other noise from other sources, both from outside the hall and from within the hall.

Two more important factors should also be considered for good acoustic design of the buildings.

1. Echo and 2. Reverberation

1. Echo :

The direct sound from the source and the reflected sound (echo) from the walls produce confusion in certain buildings. A hall with large number of open windows is free from the defect. Echoes can be eliminated by making the walls rough. But in the case of musical hall, however echoes are desirable, to a certain extent.

2. Reverberation :

The Reverberation is the prolonged reflections of sound from the walls, floor and ceiling of a hall. The sound produced in the hall undergoes multiple reflections before it becomes inaudible. As a result the clarity of the successive speech is affected. Due to this reason, the reverberation time should be optimum to hear the clear sound in the hall.

To minimize this defect, Sabine derived an equation for the reverberation time,

Where V is the volume of the hall, α is the coefficient of absorption of each reflecting surface present in the hall and A is the area of the each sound absorbing surface present in the hall.

$$T = \frac{0.16V}{\alpha A} \text{ second}$$

In the above Sabine's equation, T will be minimized by increasing the value of α . So the reverberation is minimized by covering the inner surfaces of the hall using absorption materials like carpets, wall screen, porous tiles etc.

The reverberation time value depends on the use for which the building is designed. The acceptable limit for reverberation time is

For speech, 0.5 s

For music, between 1.0 and 2.0 s

For small theatres, between 1.0 and 1.5 s

For larger theatres, up to 2.3 s

Noise Pollution :

The unwanted sounds which are dumped into the atmosphere, thus producing a nuisance and adverse effect on the health of human beings, are known as noise pollution. Noise pollution leads to severe health problems by creating either physical or mental problems. As a result, it affects the working efficiency, personal comfort, and in some cases it may lead to industrial accidents. There are varieties of noises such as domestic noise, traffic noise, aircraft noise, etc. Even though the sources of noise are numerous, the types of sources of noise are generally classified into two types.

(i) Industrial noises and (ii) Non- industrial noises

The noises which are produced due to the movements of car, motor truck, motor cycle, aircraft, machines, explosions, etc. are known as industrial noises. The noises which are produced due to the loudspeaker, construction work, radio, etc. are known as non-industrial noises. The industrial and non-industrial noises are generally measured by using the sound pressure level in decibel (dB).

Some important sound pressure level for domestic and industrial noise is listed below.

Source of noise.	Sound pressure level (dB)
Garden	20
Library	30
Ringing alarm clock	80
Heavy traffic	90
Electric generator	76
Concrete mixer	85
Power saw	90
Noisy factory	100
Threshold of pain	140

WORKED PROBLEMS

1. A wire 50 cm long and of mass 6.5×10^{-3} kg is stretched so that it makes 80 vibrations per second. Find the stretching tension.

$$m = \frac{\text{mass}}{\text{length}} = \frac{6.5 \times 10^{-3}}{0.5} = 13 \times 10^{-3} \text{ kgm}^{-1}$$

$$n = \frac{1}{2l} \sqrt{\frac{T}{m}} \text{ or } n^2 = \frac{1}{4l^2} \frac{T}{m}$$

$$\begin{aligned} \therefore \text{Tension } T &= 4l^2 m^2 n^2 = 2 \times 0.5 \times 0.5 \times 13 \times 10^{-3} \times 80 \times 80 \\ &= 83.2 \text{ N} \end{aligned}$$

2. The density of a sonometer wire of radius 0.3mm is 7800 kgm^{-3} . Find its linear density.

$$\text{Linear density } m = \pi r^2 \rho$$

$$\begin{aligned} m &= 3.14 \times (0.3 \times 10^{-3})^2 \times 7800 \\ &= 2204.28 \times 10^{-6} \\ &= 2.204 \times 10^{-3} \text{ kg m}^{-1} \end{aligned}$$

5.2 MAGNETISM

The word 'magnetism' is derived from the name of a dark brown coloured ore called magnetite found in Magnesia. The ore possesses the property of attracting small pieces of iron. The ore magnetite available in nature is called as natural magnet. Artificial magnets also can be prepared from iron or steel materials. Iron materials are mostly used to prepare electromagnets and temporary magnets whereas the steel materials are used to prepare permanent magnets.

Magnetic field:

The space around the magnet in which the magnetic lines of force act is called the magnetic field. The direction of magnetic field at a point is given by the direction of the force acting on the north pole of a magnetic needle placed at the point. If the magnetic lines of force formed are parallel, the field is called uniform magnetic field and have equal strength at all the points.

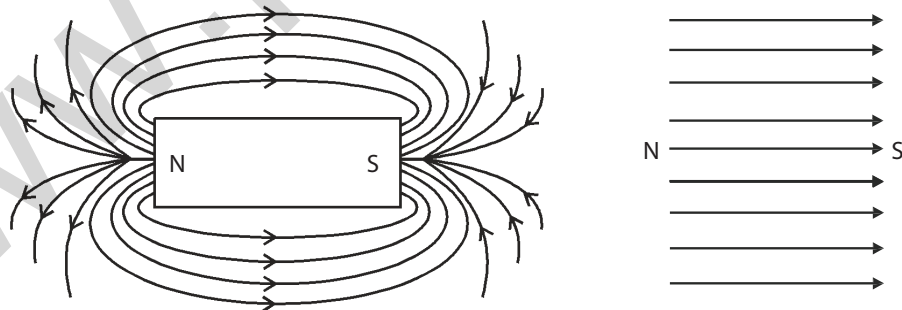
**Pole Strength (P) :**

The pole strength of a magnet is defined as the force acting on the pole when it is placed in a uniform magnetic field of unit intensity.

Let P be the pole strength placed in a uniform magnetic field of intensity H, Force acting on the pole, $F = HP$. If $H = 1$, then $F = P$ The unit of pole strength is ampere metre (Am.)

Magnetic Induction (B) :

The magnetic induction or magnetic flux density is defined as the total number of magnetic lines of force passing normally, through unit area of cross section.

The unit of magnetic induction is weber/metre².

Intensity of magnetic field (H) :

The intensity of the magnetic field at a point in a magnetic field is defined as the force experienced by a unit north pole placed at that point.

The unit of Intensity of magnetic field is ampere/metre (Am⁻¹)

Magnetic permeability (μ) :

The magnetic permeability of the medium (material) is the ratio of the magnetic induction in the medium to the intensity of magnetic field

$$\text{Magnetic permeability} = \frac{\text{Magnetic induction}}{\text{Intensity of magnetic field}} \quad \text{i.e. } \mu = \frac{B}{H} \text{ producing that induction.}$$

The unit of magnetic permeability is weber/ampere-metre (WbA m) or henry/metre.

Magnetic moment (m) :

Magnetic moment of a magnet is defined as the moment of the couple acting on a magnet when it is placed perpendicular to a uniform magnetic field of unit intensity.

Consider a magnet of length $2l$ placed perpendicular to the uniform magnetic field of intensity H . If P is the pole strength of the magnet,

Force experienced by the poles

$$F = HP$$

If $H = 1$, unit intensity of magnetic field, Force $F = P$

Two equal forces P and P acting on the magnet in opposite directions to form a couple.

$$\text{Moment of the couple} = P \times 2l$$

$$\text{i.e. Magnetic moment } M = 2lP$$

Hence, the magnetic moment of a magnet can also be defined as the product of pole strength and the distance between the poles. But, the distance between the poles is approximately equal to the length of the magnet. So, the moment can be taken as the product of pole strength and length of the magnet.

The unit of magnetic moment is ampere metre² (Am²)

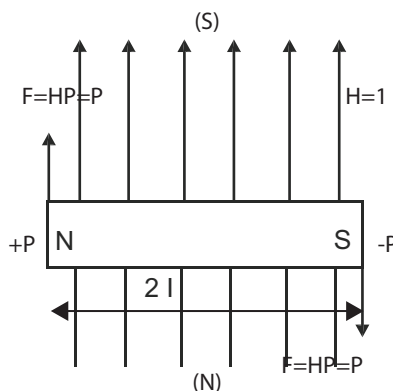

Intensity of Magnetisation (M) :

Intensity of magnetisation of a magnet is defined as the magnetic moment per unit volume of the magnet.

Let m be the magnetic moment of the magnet having volume v , then

$$\text{Intensity of magnetisation} = \frac{\text{Magnetic moment}}{\text{Volume of the magnet}}$$

$$\text{i.e. } M = \frac{m}{v}$$

The unit of intensity of magnetisation is ampere/metre (Am^{-1})

Hysteresis :

In electrical method, a magnetic material can be magnetised by keeping it inside an insulated coil (solenoid) through which a current is passed. Before passing the current, the magnetising field around the coil is zero. Then there is no magnetism induced in the material. If the magnetising field H is gradually increased by increasing the current 'I' the intensity of magnetisation induced in the material also increases upto a particular value. After that the intensity of magnetisation is not increased even though the magnetising field is increased. Now the material is said to be saturated.

If the magnetising field is gradually decreased to zero value, the intensity of magnetisation in the material also decreases but not to zero value. There is a tendency in the material to retain some amount of magnetism. Then, if the field is increased in the reverse direction from zero value, for a particular value the retained magnetism in the material is removed completely. Further increasing the field, the material attained the saturated value of magnetism in the reverse direction and so on.

Definition :

The lagging in intensity of magnetisation behind the magnetising field is known as hysteresis.

A graphical curve which represents the variation in the intensity of magnetisation (M) with magnetic field intensity (H) is known as hysteresis loop (M - H curve).

Retentivity, Coercivity and magnetic saturation :**1. Retentivity or residual magnetism :**

Retentivity or residual magnetism is the amount of intensity of magnetisation retained in the material after removing the magnetising field.

2. Coercivity or coercive force :

Coercivity or coercive force is the amount of magnetising field applied in the reverse direction to remove the residual magnetism completely from the material.

3. Magnetic saturation :

When the magnetising field is increased, the intensity of magnetisation induced in the material also increases up to a particular value. After that the intensity of magnetisation is not increased even though the magnetising field is increased. Now the material attains the saturation value of intensity of magnetisation.

Experiment to draw the Hysteresis loop:

The experimental arrangement is shown in the figure. A long solenoid is connected in a circuit. The direction of the current can be reversed by using a commutator C . The given specimen in the form of a rod is placed inside the solenoid. A deflection magnetometer is placed in Tan-A position at a short distance along the axis of the rod. The deflection magnetometer is adjusted zero position.

The intensity of magnetic field H can be calculated by using the formula $H = (NI) / L$, where N is the number of turns in the solenoid, 'I' the strength of the current passing through the solenoid and L , the length of the solenoid. The value of I can be measured by using ammeter. The intensity of magnetisation

M induced in the specimen can be calculated by using the formula $M = k \tan \theta / V$ where k is constant, θ is the deflection in the magnetometer and V is the volume of the magnet.

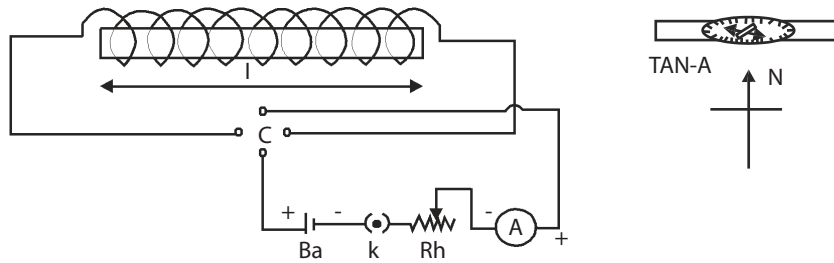

The strength of the current I is gradually increased in steps of $0.2A$ up to a required value. Every time the deflection in the magnetometer is noted. Then the values of H and the corresponding values of M are calculated. The current is decreased in steps up to zero value and again the corresponding values of H and M are calculated. The experiment is also repeated by passing the current in the reverse direction.

A graph is drawn by taking the values H along X-axis and M along Y-axis. A loop OABCDEFA is obtained as shown in the figure.

In the figure, when H is increased from zero to G , the value of M is increased from zero to A represented by OA . At the point A , the specimen reached the saturated value.

If H is decreased from G to zero, the value of M decreases from A to B , but not to zero. Now the specimen retains some amount of magnetism known as retentivity (OB).

When H is increased in the reverse direction from zero to C , the value M reaches zero value at a point C . The amount of H applied in the reverse direction to remove the residual magnetism is known as coercive force or coercivity (OC). Further repeating the process the remaining portion $CDEFA$ is obtained. The closed loop $ABCDEFA$ is called one cycle of hysteresis loop or M - H curve.

When the material is taken through a cycle of magnetisation, there is some expenditure of energy. This loss of energy dissipates in the form of heat in the specimen. The loss of energy is directly proportional to the area of the hysteresis loop.

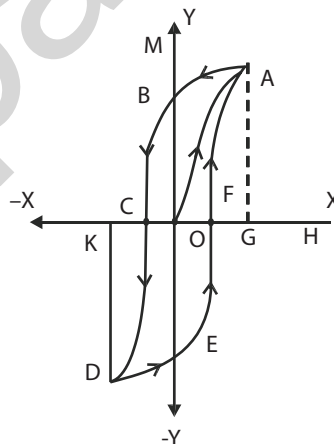

Selection of magnetic materials for permanent and temporary magnets (Uses of Hysteresis loops):

The hysteresis loops are very useful in the selection of magnetic materials for permanent and temporary magnets and other industrial purposes. The hysteresis loops for different materials are compared to one another and then the materials are selected for suitable purposes.

For example, let $ABCDEFA$ be the hysteresis loop for soft iron and $A'B'C'D'E'F'A'$ the hysteresis loop for steel. Here the area of the hysteresis loop for steel is more than that of soft iron. Therefore the loss of energy is more in steel than that in soft iron. Hence the quantity of heat emitted by steel is more

than that by soft iron. For this reason soft iron is selected as a core materials for transformers, chokes, AC motors, dynamos, etc.

The retentivity of soft iron (OB) is more than that for steel (OB'). So, soft iron retains more magnetism than steel. But the coercivity for soft iron (OC) is less than the coercivity for steel (OC'). So the strength of the magnetic field needed to remove the residual magnetism in soft iron is less than in steel. That means it is easy to remove the residual magnetism in soft iron than steel. Hence steel retains the magnetism during long period. For the above reasons steel is used for permanent magnets and soft iron is used for temporary magnets and electromagnets.

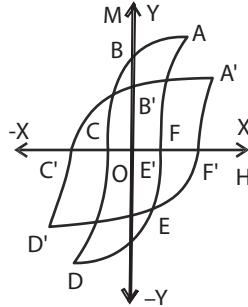

WORKED PROBLEM

1. The length ,breath and thickness of a bar magnet are 30cm, 2cm and 1 cm respectively.if its magnetic moments is $6 \times 10^{-6} \text{ Am}^2$, calculate the intensity of magnetisation

$$l = 30 \text{ cm or } 0.30 \text{ m}, b = 2 \text{ cm or } 0.02 \text{ m} \text{ and } h = 1 \text{ cm or } 0.01 \text{ m}$$

$$m = 6 \times 10^{-6} \text{ Am}^2$$

$$\text{Volume} = lbh = 0.30 \times 0.02 \times 0.01 = 0.00006$$

$$\text{Intensity of magnetization}(M) = m/v = 6 \times 10^{-6} / 0.00006$$

$$M = 0.1 \text{ Am}^{-1}$$

QUESTIONS

Part - A and Part – B

1. Define wave motion.
2. Define transverse wave motion.
3. Define longitudinal wave motion.
4. Define progressive wave.
5. Define amplitude of a wave.
6. Define wavelength of a wave.
7. Define period of wave motion.
8. Define frequency of a wave.
9. Define velocity of sound wave.
10. Define stationary wave.
11. Define free vibrations.
12. Define forced vibrations.
13. Define Resonance.
14. State any one of the laws of transverse vibrations in stretched strings.

15. What is the use of a sonometer?
16. What is an echo?
17. What is reverberation?
18. What is reverberation time?
19. Write Sabine's formula.
20. Define coefficient of absorption of sound energy.
21. Define Pole Strength.
22. Define magnetic induction.
23. Define intensity of magnetic field.
24. Define permeability.
25. Define magnetic moment of a magnet.
26. Define intensity of magnetisation.
27. Define Hysteresis.
28. Define Retentivity
29. Define coercivity
30. Define magnetic saturation.
31. Explain transverse wave motion.
32. Explain longitudinal wave motion.
33. Explain stationary wave
34. Explain the laws of transverse vibration of stretched string
35. What are the important factors of good acoustics
36. Explain noise pollution
37. Explain resonance
38. Explain Hysteresis
39. Write the uses of hysteresis loop.

Part – C

1. Explain transverse wave motion and longitudinal wave motion.
2. Distinguish between transverse and longitudinal wave motion.
3. Explain the laws of transverse vibrations in a stretched string and obtain the expression for the frequency of vibration.
4. Describe how the frequency of a tuning fork is determined using a sonometer.
5. Write a note on acoustics of buildings.
6. Explain noise pollution and the methods of controlling industrial noise.
7. Describe the method of drawing hysteresis loop of a specimen using a solenoid.
8. Explain and uses of hysteresis loop.

Exercise Problems

1. A sonometer wire of 0.5 m long gives vibrations of 256 Hz when stretched with a load of 5 kg. Find the linear density of the material of the wire.
2. Find the frequency of sound produced by a string 25 cm long stretched by load of 5 kg. The linear density of the wire is $4.9 \times 10^{-3} \text{ kgm}^{-1}$
3. A string 75 cm long and weighing 15 g produces a note of frequency 100 cycles per second on plucking. What is the tension in the string?

Ans: 450 N

4. A wire of 50 cm long and of mass $6 \times 10^{-3} \text{ kg}$ is stretched so that it makes 60 vibrations per second. Find the tension in the wire.

Ans: 43.20 N

5. The vibrating length of 0.75 m of a sonometer wire is unison with a tuning fork when stretched by weight of 5 kg. The linear density of the wire is $0.5 \times 10^{-3} \text{ kg m}^{-1}$. Calculate the frequency of the tuning fork.

Ans: 209 Hz

6. A wire 50 cm long and of mass $0.6 \times 10^{-3} \text{ kg}$ is stretched by a tension of 4 kg.wt. When sounded, it is found to vibrate in 2 loops. Calculate the frequency of the note emitted by the wire.

Ans: 361.Hz

7. A wire 0.5 m long vibrates 100 times a second. If the length of the wire is shortened to 0.4 m and the stretching force is increased to 4 times its original value, what will be the new frequency?

Ans : 250 Hz

Brain Teaser

1. Thunder was heard 6 second after a flash of lighting was seen. If the velocity of sound is 345ms^{-1} , calculate the distance at which flash occurred.
2. Two magnetic poles, one of which is twice stronger than the other repel one another with a force of $2 \times 10^{-5} \text{ N}$ when kept separated at a distance of 20 cm in air. Calculate the strength of each pole.

Padeepz App

NOTES

www.padeepz.net

Padeepz App

**FIRST SEMESTER
PRACTICAL-I**

www.padeepz.net

FIRST SEMESTER

PRACTICAL-I

MICROMETER (SCREW GAUGE)

Experiment No.

Date:

Aim:

To measure the thickness of the given irregular glass plate, using a micrometer. To measure area of the glass plate using a graph sheet and to calculate the volume of the glass plate.

Apparatus required:

Screw gauge, graph sheet and given glass plate.

Formula:

Volume of the glass plate = Thickness \times area of the glass plate m^3

Thickness of glass plate = Observed Reading + Zero Correction
 $= \{PSR + (HSC \times LC)\} + ZC$

Where PSR = Pitch scale reading
 HSC = Head scale coincidence
 LC = Least Count
 ZC = Zero Correction

Head Scale Reading (HSR) = Head Scale coincidence \times Least Count

Observed Reading (OR) = Pitch Scale Reading + Head Scale Reading

Correct Reading (CR) = Observed Reading + zero Correction

Description:

The screw gauge consists of a screw working in a hollow cylindrical nut attached to one end of a frame G. On the hollow cylinder a scale is marked in mm. This scale is called the pitch scale (PS). There is a fixed stud A at one end of the frame and exactly opposite to A, there is a movable stud B of the screw. The other end of this screw has a head H. To the head, a hollow sleeve is attached. On the tapering of the sleeve 50 or 100 divisions are marked. This scale is called the Head Scale (HS). The Screw gauge head is having a ratchet arrangement, to avoid over-working of the screw.

Procedure:

i) To find the least count (LC):

Least count is the minimum measurement that can be made with the given instrument.

First, the pitch of the screw is determined; by giving a known number of rotations to head scale and noting the distance advanced in pitch scale in mm. Then the number of divisions in the head scale is also noted.

The pitch and least count are determined using the formulae.

Padeepz App

ii) To find Zero Error (ZE) and Zero Correction (ZC):

The Screw gauge is checked to find whether there is any initial (zero) error in the instrument. If there is any initial error, suitable correction is to be made.

When the studs A and B touch each other, if the zero of the head scale lies on the same line as that of the pitch scale index line(I.L), the instrument has no error.

If the zero of the head scale is above the index line, it has negative error. So the zero correction is positive.

If the zero of the head scale is below the index line, it has positive error. So the zero correction is negative.

The type of error (ZE) and the suitable zero correction (ZC) for the given micrometer is determined with the help of figures and formulae given.

iii) To find thickness of the glass plate:

The given glass plate is placed gently in between the two studs A and B and the ratchet is rotated till the glass plate is firmly but gently gripped. Note the number of completed divisions in mm on the pitch scale as Pitch scale reading (PSR) and the divisions on the head scale, which coincides with the index line as head scale coincidence (HSC). The PSR and HSC are entered in the tabular column. Then the head scale reading (HSR), observed reading (OR) and correct reading (CR) are calculated. The procedure is repeated for different positions of the glass plate and the average thickness of the glass plate is calculated.

iv) To measure the area of the glass plate:

The given irregular glass plate is placed on a graph sheet. The trace of the glass plate is drawn on the graph sheet. The number of squares inside the trace in mm^2 is counted. This gives the area of the glass plate in mm^2 .

By multiplying the thickness of the glass plate and the area of the glass plate, the volume of the glass plate is determined.

Result:

The thickness of the given glass plate = $\times 10^{-3}$ m

The area of the glass plate = $\times 10^{-6}$ mm^2

The volume of the glass plate = $\times 10^{-9}$ mm^3

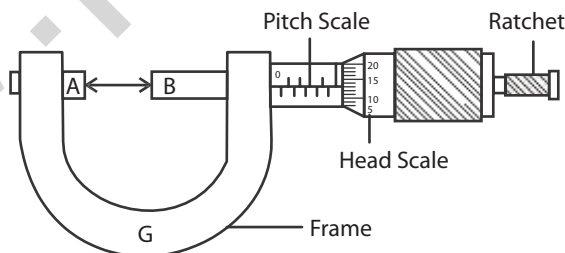

Observations:

(i) Least Count:

$$\text{Least count} = \frac{\text{Pitch of the screw}}{\text{No. of head scale division}}$$

$$\begin{aligned} \text{Pitch of the screw} &= \frac{\text{Distance moved in the pitch scale}}{\text{No. of rotations given to HS}} \\ &= \text{mm} \end{aligned}$$

Number of head scale divisions(HSD) = div

$$\text{Therefore, Least Count (LC)} = \frac{\text{pitch}}{\text{No.of HSD}} = \text{mm}$$

$$\text{LC} = \text{mm}$$

Three possible initial error and initial correction:

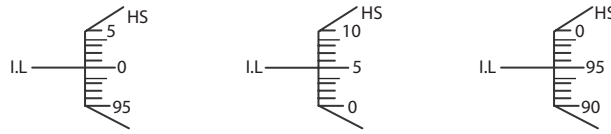

No error

No correction

Positive error

Negative correction

$$\text{HSC} = 5 \text{ div}$$

$$\text{ZE} = + (\text{HSC} \times \text{LC})$$

$$= + (5 \times 0.01 \text{ mm})$$

$$= + 0.05 \text{ mm}$$

$$\text{ZE} = + 0.05 \text{ mm}$$

$$\text{ZC} = - 0.05 \text{ mm}$$

Negative error

Positive correction

$$\text{HSC} = 95 \text{ div}$$

$$\text{ZE} = - (100 - \text{HSC}) \times \text{LC}$$

$$= - (100) \times 0.01 \text{ mm}$$

$$= - 5 \times 0.01 \text{ mm}$$

$$\text{ZE} = -0.05 \text{ mm}$$

$$\text{ZC} = + 0.05 \text{ mm}$$

(ii) Zero error and zero correction for the given screw gauge:

Tabular Column:

To find the thickness of the given glass plate:

$$\text{LC} = \text{mm} \quad \text{ZE} = \text{mm} \quad \text{ZC} = \text{mm}$$

Sl. No.	PSR	HSC	HSR = HSC × LC	OR = PSR + HSR	Thickness CR = OR + ZC
Unit	mm	div	mm	mm	mm
1.					
2.					
3.					
4.					
5.					

The average thickness of the given glass plate = mm

= × 10⁻³ m

Area of the glass plate using graph sheet = mm²

= × 10⁻⁶ m²

Volume of the glass plate = Thickness × Area

=

= m³

Padeepz App

VERNIER CALIPERS

Aim:

To measure the length and diameter of the given solid cylinder using vernier calipers and to calculate the volume of the solid cylinder.

Apparatus required:

Vernier calipers and solid cylinder.

Formula:

$$\text{Volume of the solid cylinder} = \pi r^2 l \text{ m}^3$$

Where

l = length of the cylinder

r = radius of the cylinder

$$\begin{aligned} \text{Length / diameter of the solid cylinder} &= \text{Observed reading} + \text{Zero correction} \\ &= \{ \text{MSR} + (\text{VSC} \times \text{LC}) \} + \text{ZC} \end{aligned}$$

Where MSR = Main Scale Reading

VSC = Vernier Scale Coincidence

LC = Least Count

ZC = Zero Correction

Vernier Scale Reading (VSR) = Vernier Scale Coincidence (VSC) \times Least Count (LC)

Observed Reading (OR) = Main Scale Reading (MSR) + Vernier Scale Reading (VSR)

Correct Reading (CR) = Observed Reading (OR) + Zero Correction (ZC)

Description:

The vernier calipers consists of main scale (MS) graduated in cm along the lower edge of the frame and inches along the upper edge of the frame. To one end of the frame, two fixed jaws are provided. There are two movable jaws, which slide over the main scale, and it can be fixed at any point using a screw S. The movable jaw attachment carries a vernier scale (VS).

Procedure:

i) To find the Least Count :

Least Count is the minimum measurement that can be made with the given instrument.

The value of 1 main scale division (MSD) and number of divisions (n) on the vernier scale are determined. The least count of the instrument is calculated using the formula

$$\text{Least Count (LC)} = \frac{1}{n} \times \text{value of 1MSD}$$

ii) To find the Zero Error (Z.E) and Zero Correction(Z.C) :

The instrument is checked to find whether there is any initial error. If there is any initial error, suitable correction is to be made.

When the two jaws are in contact, the graduations are made such that the zero of the MS coincides with the zero of the VS. Now the instrument has no error.

If the zero of the VS is on the right side of the zero of the MS, it has positive error. Then the zero correction is negative.

If the zero of the VS is on the left side of the zero of the MS, it has negative error. Then zero correction is positive.

In each case, note the division of the vernier scale which is coinciding with any one of the main scale divisions. This is vernier scale coincidence (VSC). Applying this in the given formula, the value of zero error is determined. Hence zero correction (ZC) is also determined.

iii) To find the length and diameter of the solid cylinder :

The given cylinder is gently placed in between the two lower jaws of the vernier calipers such that the length of the cylinder is parallel to the scale.

The completed main scale reading (MSR) is taken by noting the position of zero of the vernier scale. The vernier scale coincidence (VSC) is then noted. VSC is that particular division which coincides with any one of the main scale divisions, making a straight line.

The MSR and VSC are noted in the tabular column I for different settings of the cylinder. Then the Vernier Scale Reading (VSR), Observed Reading (OR) and Correct Reading (CR) are calculated using the formula given. The average value of CR is determined, which gives the length of the given cylinder.

Similarly the readings for diameter of the solid cylinder are taken by placing the cylinder suitably in between the lower fixed jaws and the readings are noted in the tabular column II.

Result:

The length of the solid cylinder $l = \quad \times 10^{-2}$ m
 The diameter of the solid cylinder $d = \quad \times 10^{-2}$ m
 The volume of the solid cylinder $v = \quad \times 10^{-6}$ m³

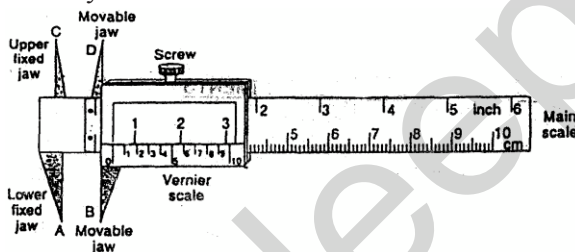

Observations :

(i) Least count :

Value of 10 MSD = \quad cm
 Value of 1 MSD = \quad cm
 No. of division on the vernier scale (n) = \quad

(ii) The three possible initial error and initial correction :

Least Count (LC) = $\frac{1}{n} \times \text{value of 1 MSD} = \quad = \quad$ cm
 No error Positive error Negative error
 No correction Negative correction Positive correction
 M.S M.S M.S

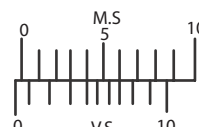
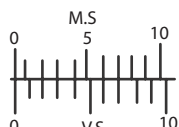
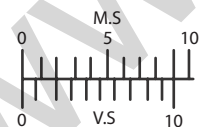

VSC = 3 div VSC = 7 div
 ZE = + (VSC) × LC ZE = -(10-VSC) × LC
 = + 3 × 0.01 cm = - (10-7) × 0.01 cm
 = + 0.03 cm = - 0.03 cm
 ZC = - 0.03 cm ZC = + 0.03 cm

Zero error and zero correction of the given vernier calipers:

Tabular column I :

To find the length of the solid cylinder

$$LC = \text{cm} \quad ZE = \text{cm} \quad ZC = \text{cm}$$

Sl. No	MSR	VSC	VSR = VSC x LC	OR = MSR + VSR	Length CR = OR + ZC
Unit	cm	div	cm	cm	cm
1					
2					
3					
4					
5					

$$\begin{aligned} \text{The average length of the solid cylinder (L)} &= \text{cm} \\ &= \times 10^{-2} \text{ m} \end{aligned}$$

Tabular column II :

To find the diameter of the solid cylinder

$$LC = \text{cm} \quad ZE = \text{cm} \quad ZC = \text{cm}$$

Sl. No	MSR	VSC	VSR = VSC x LC	OR = MSR + VSR	Diameter CR = OR + ZC
Unit	cm	div	cm	cm	cm
1					
2					
3					
4					
5					

$$\begin{aligned} \text{The average diameter of the solid cylinder (D)} &= \text{cm} \\ &= \times 10^{-2} \text{ m} \end{aligned}$$

$$\text{The average radius of the solid cylinder 'r'} = \times 10^{-2} \text{ m}$$

$$\begin{aligned} \text{Volume of the solid cylinder} &= \pi r^2 l \\ &= \text{m}^3 \end{aligned}$$

CONCURRENT FORCES**Aim:**

To verify i) Parallelogram law of forces and ii) Lami's theorem.

Apparatus required:

Vertical drawing board, two pulleys with clamps, three sets of slotted weights, thread, white paper, scale, protractor, compass and pencil.

Formula:

1. To verify the parallelogram law of forces, it is to be shown that Resultant = Equilibrant and they are opposite in directions. i.e. $OD = OC$ and $\angle COD = 180^\circ$ where OD and OC are lines drawn representing the resultant and equilibrant of P and Q.
2. To verify Lami's theorem, it is to be shown that

$$\frac{P}{\sin \alpha} = \frac{Q}{\sin \beta} = \frac{R}{\sin \gamma}$$

where P, Q and R are the forces α, β and γ are the angles opposite to P, Q and R respectively.

Description:

A drawing board is supported vertically on a wall. The two smooth pulleys are fixed at the two top corners of the board, so that they can rotate freely. The two weight hangers P and Q are attached to the two ends of a long thread, after passing through the pulleys. The third weight hanger R is attached to the middle of the thread as shown in the figure.

Procedure:

The weights in the hangers P, Q and R are adjusted such that the point O is at rest. A small displacement is given to the system so as to overcome the friction in the pulleys. A drawing paper is fixed on the board, behind the strings. The trace of the three strings is taken on the sheet of paper, using an adjustable lamp arrangement in front of the threads. The trace sheet is removed and the lines are joined to get the image of the threads. These lines meet at a point O.

i) To verify parallelogram law of forces:

Taking a suitable scale ($0.050 \text{ kg} = 1 \text{ cm}$) OA, OB and OC are marked to represent the forces P, Q and R respectively both in magnitude and in direction. With OA and OB as adjacent sides, a parallelogram OADB is completed. The length of the diagonal OD is measured and entered in the tabular column. Also the $\angle COD$ is measured and entered in the tabular column I.

According to parallelogram law, the diagonal OD gives the resultant of P and Q, where OC is the equilibrant of P and Q.

The procedure is repeated thrice with different combinations of P, Q and R.

ii) To verify Lami's theorem:

In all the three figures drawn in the trace sheet, the angles between the forces are marked. The angle between the forces Q and R is marked as α . The angle between the forces R and P is marked as β . The angle between the forces P and Q is marked as γ as shown in the figure. The angles are measured and entered in the corresponding tabular column II. To check the accuracy of angle measurement, for each case, the sum of the three angles measured should be equal to 360° . i.e. $(\alpha + \beta + \gamma) = 360^\circ$.

Then the calculations are done using the given formula and the values are entered in the tabular column.

Result:

1. In the tabular column I, in all cases, it is seen that Resultant = Equilibrant i.e. $OD = OC$ and also $\angle COD = 180^\circ$, which verifies parallelogram law of forces.
2. In the tabular column II, in all cases, it is seen that the values in the last three columns are found to be equal.

which verifies Lami's theorem.

$$\text{i.e. } \frac{P}{\sin \alpha} = \frac{Q}{\sin \beta} = \frac{R}{\sin \gamma}$$

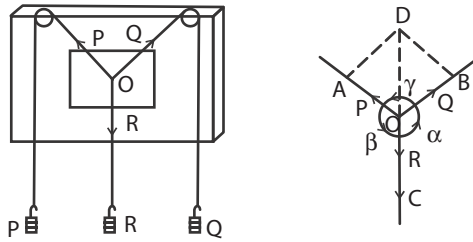

Tabular Column I :

To verify parallelogram law of forces

Scale : 0.05 kg.wt = 1 cm

Sl.No.	Force P	Line OA	Force Q	Line OB	Force R	Equi-brant OC	Resultant OD	∠COD
Unit	kg. wt	cm	kg. wt	cm	kg. wt	cm	cm	degree
1.								
2.								
3.								

Tabular Column II:

To verify Lami's Theorem

Sl. No.	Forces			Angles			$\frac{P}{\sin \alpha}$	$\frac{Q}{\sin \beta}$	$\frac{R}{\sin \gamma}$
	P	Q	R	α	β	γ			
Unit	kg. wt	kg. wt	kg. wt	degree	degree	degree	kg. wt	kg. wt	kg. wt
1.									
2.									
3.									

Calculation:

$$1. \quad P = \quad \text{kg. wt}, \quad Q = \quad \text{kg. wt}, \quad R = \quad \text{kg. wt}$$

$$\alpha = \quad ^\circ, \quad \beta = \quad ^\circ, \quad \gamma = \quad ^\circ$$

$$\frac{P}{\sin \alpha} =$$

$$\frac{Q}{\sin \beta} =$$

$$\frac{R}{\sin \gamma} =$$

$$2 \quad P = \text{kg. wt}, \quad Q = \text{kg. wt}, \quad R = \text{kg. wt}$$

$$\alpha = \circ \quad \beta = \circ \quad \gamma = \circ$$

$$\frac{P}{\sin \alpha} =$$

$$\frac{Q}{\sin \beta} =$$

$$\frac{R}{\sin \gamma} =$$

$$3. \quad P = \text{kg. wt}, \quad Q = \text{kg. wt}, \quad R = \text{kg. wt}$$

$$\alpha = \circ \quad \beta = \circ \quad \gamma = \circ$$

$$\frac{P}{\sin \alpha} =$$

$$\frac{Q}{\sin \beta} =$$

$$\frac{R}{\sin \gamma} =$$

Comparison of Co-efficients of Viscosities of two liquids by capillary flow method

Experiment No.:

Date:

Aim:

Aim:

To compare the coefficient of viscosity of two given liquids by capillary flow method,.

Apparatus required :

Burette stand, graduated burette without stopper, Capillary tube, rubber tube, beaker, stop watch, water, funnel, wooden bench, etc.

Formula:

The comparison of coefficient of viscosity

$$(\eta_1 / \eta_2) = (\rho_1 / \rho_2) \times (t_1 / t_2)$$

η_1 = coefficient of viscosity of first liquid

η_2 = coefficient of viscosity of second liquid

ρ_1 = Density of the first liquid

ρ_2 = Density of the second liquid

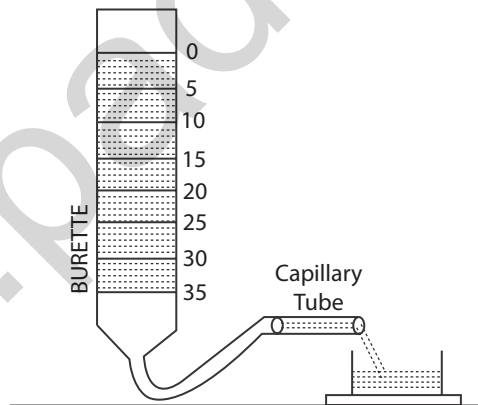
**Description:**

The graduated burette without stopper is mounted vertically in the stand. A rubber tube is connected to the bottom of the burette. To the other end of the tube, a capillary tube is inserted and placed in a perfectly horizontal position.

Procedure:

The burette is cleaned and filled with one of the liquids using a funnel. Adjust the tube till the liquid through the tube comes out drop by drop. A stop clock is started when the liquid level reaches 0 cc and time taken for every 5 cc from 5,10, 15,20..till 50cc, is noted .The time taken by the liquid (t_1) to flow from 0 to 15, 5 to 20, 10 to 25... are found out The burette and the tube are cleaned,rinsed and filled with the second liquid The time taken to cross the every consecutive 5 ml is noted. The reading are tabulated.

The time taken for the t_1 and t_2 are noted. The mean value of t_1 / t_2 is calculated

Result:

The ratio of coefficients of viscosities of the two liquids =

Tabular column

Sl.No	Burette Reading CC	Time of flow of liquid (second)	
		Liquid I	Liquid II
1			
2			
3			
4			
5			
6			
7			
8			
9			
10			

Sl.No.	Range CC	Time of flow (second)		t_1 / t_2
		Liquid I (11)	Liquid II (12)	

Mean

Observations:

Density of the first liquid (water) = 1000 kgm⁻³

Density of the second liquid (kerosene) = 800 kgm⁻³

Average ratio of the time of flow (t_1 / t_2) =

Calculation

The comparison of coefficient of viscosity

$$(\eta_1 / \eta_2) = (\rho_1 / \rho_2) \times (t_1 / t_2)$$

COEFFICIENT OF VISCOSITY OF HIGH VISCOUS LIQUID – STOKES' METHOD

Experiment No.:

Date:

Aim:

To determine the coefficient of viscosity of high viscous liquid (Castor oil) by Stokes' method.

Apparatus Required

A tall glass jar, castor oil, glass beads of different radii, stopwatch, screw gauge, etc.

Formula:

The coefficient of viscosity of the highly viscous liquid $\eta = \frac{2(\rho - \sigma)g(r^2t)}{9h} \text{ Nsm}^{-2}$

Where

ρ = the density of the material of the solid sphere (glass beads)

σ = the density of the liquid (castor oil)

g = the acceleration due to gravity

r = the radius of the glass beads

t = the time taken by the solid sphere to travel the marked distance h , inside the high viscous liquid.

h = the distance between the marks B and C

Description:

The pure, transparent, high viscous liquid (castor oil) is taken in the tall glass jar. On the outer surface of the jar, two markings B and C are made at a distance of say 50 cm. The marking B should be well below the free surface of the liquid. Then only the sphere can attain terminal velocity when travelling from B to C.

Procedure:

First the least count, zero error and zero correction of screw gauge are determined. Then using the screw gauge, the diameters of the given glass beads are measured. The radii of the beads are calculated. Values of r and s are taken from standard tables.

The sphere is placed gently on the surface of the high viscous liquid and dropped. When it crosses the marking B, a stop clock is started and when it crosses the marking C, the clock is stopped. The time taken (t) to travel by the sphere from B to C is recorded in the tabular column. The distance between B and C is noted as ' h '. The same procedure is repeated for all the given spheres. Then the coefficient of viscosity of highly viscous liquid (castor oil) is calculated, using the formula.

Result:

The coefficient of viscosity of the high viscous liquid (castor oil) =

N s m^{-2}

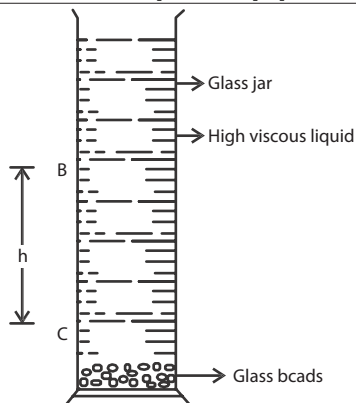

Observations:

- The density of the material solid sphere (glass beads) $r = \text{kg m}^{-3}$
- The density of the viscous liquid (castor oil) $s = \text{kg m}^{-3}$
- The acceleration due to gravity $g = \text{m s}^{-2}$
- The distance between B and C $h = \times 10^{-2} \text{ m}$

$$\text{Pitch of the screw} = \frac{\text{Distance moved in pitch scale}}{\text{No. of rotations given to HS}}$$

(I) Least Count: $\text{Least Count} = \frac{\text{Pitch}}{\text{No. of Head Scale Divisions}}$
 $= \text{mm} = \text{mm}$

Therefore, $\text{Least Count (LC)} = \frac{\text{pitch}}{\text{No. of HSD}} = \text{mm}$

Number of head scale divisions(HSD) = div
 LC = mm

(ii) Zero Error and Zero Correction:

Tabular column I:

To find the radii of the solid spheres (glass beads)

LC = mm; ZE = mm; ZC = mm

Solid sphere	Sl. No.	PSR	HSC	HSR = (HSC × LC)	OR = PSR + HSR	CR = OR + ZC	Mean diameter d	Radius r = d/2
	Unit	mm	div	mm	mm	mm	mm	mm
Bead 1	1.							
	2.							
	3.							
	4.							
	5.							
Bead 2	1.							
	2.							
	3.							
	4.							
	5.							

Bead 3	1.							
	2.							
	3.							
	4.							
	5.							

Tabular column II:

To find r^2t

Glass beads	Radius r	Radius ² r ²	Time taken t	r ² t
Unit	mm	mm ²		mm ²
Bead 1				
Bead 2				
Bead 3				

$$\begin{aligned} \text{The average of } r^2t &= \text{mm}^2 \\ &= \times 10^{-6} \text{ m}^2 \end{aligned}$$

Calculation:

The coefficient of viscosity of the highly viscous liquid

$$\begin{aligned} (\text{castor oil}) \eta &= \frac{2(\rho - \sigma)g(r^2 t)}{9h} \\ &= \\ &= \text{Nsm}^{-2} \end{aligned}$$

SURFACE TENSION

Experiment No.:

Date:

Aim:

To determine the surface tension of water by capillary rise method.

Apparatus required:

Beaker with water, capillary tube, pointer, travelling microscope, retort stand with clamp, two holed rubber cork, wooden bench, etc.

Formula:

The surface tension of water $T = \frac{h r \rho g}{2} \text{ Nm}^{-1}$

where

h = height of the liquid rise in the capillary tube

r = radius of the capillary tube

ρ = density of water

g = acceleration due to gravity

Description:

A capillary tube of uniform cross sectional area is cleaned well and clamped vertically with one end inside the water taken in a beaker. Due to surface tension, water rises to a definite height into the tube. This is called capillary rise. If there is any air bubble inside the tube, it should be removed. A pointer is mounted vertically so that its lower end just touches the surface of water in the beaker.

Procedure:

The least count of the microscope is determined as in the case of vernier calipers.

The microscope is adjusted such that the horizontal cross wire is tangential to the lower meniscus of the liquid inside the capillary tube. The MSR and VSC from the vertical scale of the microscope are noted. Then the beaker of water is removed, without disturbing the pointer. Now the microscope is focussed so that the horizontal cross wire is tangential to the tip of the pointer. The MSR and VSC readings are noted in the tabular column. The difference between these two observed readings (O.R) gives the height of capillary rise 'h'.

The capillary tube is mounted horizontally and the microscope is focussed to one end of the tube, so that we can see the bore of the capillary tube in the field of view.

Now, the horizontal cross wire is made tangential to one side of the bore (AA'). The readings are noted in the tabular column from the vertical scale. Using the minute adjustment screw of the microscope, the horizontal cross wire is made tangential to the other side of the bore (BB') and the readings are noted. The difference between these two observed readings (O.R) gives the diameter of the capillary tube. Hence the radius of the capillary tube is determined.

Then the surface tension of water is calculated using the formula.

Result:

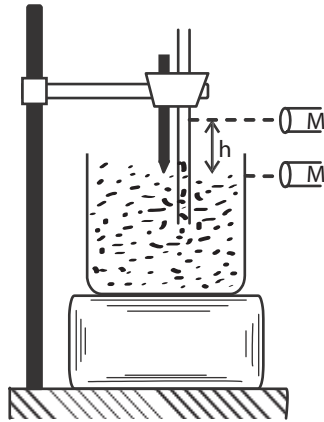

The surface tension of water is found to be = N m^{-1}

Observations:

Density of water (ρ) = kgm^{-3}

Acceleration due to gravity (g) = m^{-2}

To find Least count of microscope:

Least count:

Value of 20 MSD = cm

value of 1 MSD = cm

Least Count (LC) = $\frac{1}{n} \times \text{value of 1MSD}$

No. of divisions on the vernier scale (n) =
 =
 = cm

Tabular column I:

To find the height of capillary rise h

Position	Microscope Readings				Height of the capillary rise $h = (x \sim y)$
	MSR	VSC	VSR = VSC \times LC	OR = MSR + VSR	
Unit	cm	div	cm	cm	cm
Horizontal cross wire at the lower meniscus				x =	
Horizontal cross wire at the tip of the pointer				y =	

Least count = cm

Height of the liquid rise in the capillary tube(h) = cm
 = $\times 10^{-2}$ m

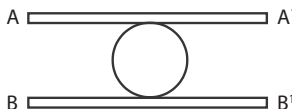

Tabular column II

To find the radius of capillary tube r :

Least count = _____ cm

Position	Microscope Readings				Diameter 2r = (A ~ B)
	MSR	VSC	VSR = VSC × LC	OR = MSR + VSR	
Unit	cm	div	cm	cm	cm
AA'				A =	
BB'				B =	

The diameter of the capillary tube d = _____ cm

The radius of the capillary tube r = d/2 = _____ cm

r = _____ × 10⁻² m

Calculation:

The surface tension of water $T = \frac{h r \rho g}{2}$

Height of the liquid rise in the capillary tube h = _____ × 10⁻² m

Radius of the capillary tube r = _____ × 10⁻² m

Density of the water ρ = _____ kg m⁻³

$T = \frac{h r \rho g}{2} =$ _____ Nm⁻¹

Result: The Surface tension of water is found to be = _____

SONOMETER

Experiment No.:

Date:

Aim:

To find the frequency of the given tuning fork using a sonometer.

Apparatus Required:

The frequency of the tuning fork $n = \frac{1}{2} \sqrt{\left(\frac{M}{l^2}\right) \frac{g}{m}}$ Hz

Sonometer, screw gauge, tuning fork, hammer, weight hanger set and paper rider.

Formula:

Where

M = total mass at the end of the sonometer wire.

i.e. Mass of the weight hanger + Mass placed on it

g = acceleration due to gravity.

m = linear density of the wire

i.e., mass per unit length of the wire.

l = first resonating length.

The linear density of the wire, $m = \pi r^2 \rho$

Where

ρ = density of the material of the wire.

r = radius of the sonometer wire.

Description :

A sonometer consists of a hollow wooden box about one metre with bridges A and B fixed at two ends on the top surface. A uniform wire is stretched over the two bridges, one end of the wire being fixed to the nail at one end of the box. The other end passes over a smooth pulley and carries a weight hanger on which weights can be placed. M and N are two movable bridges in between the fixed bridges A and B. By changing their position, the length of the vibrating segment of the wire can be altered.

Procedure:

A suitable load say 0.5 kg is placed on the hanger. The two movable bridges M and N are placed close to each other. A light paper rider is placed at the centre of the segment MN of the sonometer wire. The given tuning fork is excited and its stem is pressed on the sonometer box. The length of the vibrating segment MN is gradually increased by moving the bridge M or N, till the paper rider flutters violently and fall down. The first resonating length l between M and N is measured using the metre scale fixed on the sonometer box. The load is changed to 1 kg, 1.5 kg, 2 kg, 2.5 kg, 3 kg etc and in each case the resonating length is determined and M/l^2 is calculated.

The diameter d of the wire is found using a screw gauge. The radius of the wire r is calculated. The mass per unit length of the wire is $m = \pi r^2 \rho$. Here ρ is the density of the material of the wire.

The frequency of the given tuning fork is calculated by substituting the values of M/l^2 and 'm' in the formula.

Result:

The frequency of the given tuning fork (n) = Hz.

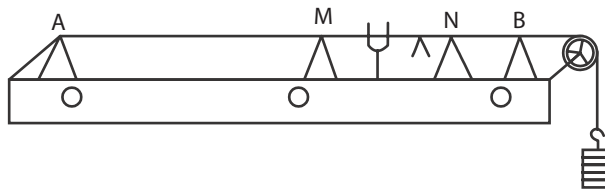

Observations:

Acceleration due to gravity $g = \text{ms}^{-2}$
 Density of the material of the wire (steel) $\rho = \text{kg m}^{-3}$

$$\text{Pitch of the screw} = \frac{\text{Distance moved in pitch scale}}{\text{No. of rotations given to HS}} =$$

(i) Least Count: Least Count = Pitch / No. of Head Scale Divisions

$$\text{Therefore, Least Count (LC)} = \frac{\text{pitch}}{\text{No. of HSD}} = \text{mm}$$

$$= \text{----- mm} = \text{mm}$$

Number of head scale divisions(HSD) = div

$$\text{LC} = \text{mm}$$

(ii) Zero Error and Zero Correction:

Tabular column I:

To find $\frac{M}{l^2}$

Sl. No.	Mass placed at the end of the sonometer wire [mass of the hanger + mass placed on the hanger] M		First resonating length l		l^2	$\frac{M}{l^2}$
	Unit	Kg	cm	m		
1.	Hanger + 0.5	1.0				
2.	Hanger + 1.0	1.5				
3.	Hanger + 1.5	2.0				
4.	Hanger + 2.0	2.5				
5.	Hanger + 2.5	3.0				

Tabular Column II:

To find the diameter of the wire

$$\text{LC} = \text{mm} \quad \text{ZE} = \text{mm} \quad \text{ZC} = \text{mm}$$

Sl. No.	PSR	HSC	HSR = HSC × LC	OR = PSR + HSR	CR = OR + ZC
Unit	mm	div	mm	mm	mm
1.					
2.					
3.					
4.					
5.					

Mean

$$\begin{aligned}
 \text{The average diameter of the wire} &= \text{m m} \\
 \text{Radius of the wire } r = d/2 &= \text{m m} \\
 R &= \times 10^{-3} \text{ m}
 \end{aligned}$$

Calculation:

$$\begin{aligned}
 \text{The Mass per unit length of the wire } m &= \pi r^2 \rho \\
 &= \\
 &= \text{kg m}^{-1} \\
 \text{The frequency of the tuning fork } n &= \frac{1}{2} \sqrt{\left(\frac{M}{l^2}\right) \frac{g}{m}} \\
 &= \\
 &= \text{Hz}
 \end{aligned}$$

DEFLECTION MAGNETOMETER (TAN A – POSITION) COMPARISON OF MAGNETIC MOMENTS

Experiment No.:

Date:

Aim:

To compare the magnetic moments of the given two bar magnets using a deflection magnetometer in Tan A position, by equal distance method.

Apparatus Required:

$$\frac{m_1}{m_{11}} = \frac{\tan \theta_1}{\tan \theta_{11}} \quad (\text{No unit})$$

Deflection magnetometer, two bar magnets, metre scale, etc.

Formula:

The ratio of the magnetic moments of two given short bar magnets where

m_1 = the magnetic moment of first magnet

m_{11} = the magnetic moment of second magnet

θ_1 = mean deflection for first magnet

θ_{11} = mean deflection for second magnet

Description:

The magnetometer is arranged in tan A position. For arranging tan A position the following adjustments are to be made.

i) The magnetometer is placed on a horizontal table and the arms of the magnetometer are kept along the east-west direction and it is adjusted so that the arms are parallel to the length of the aluminium pointer.

ii) Without disturbing the adjustment, the compass box is slowly rotated until the pointer reads $0^\circ - 0^\circ$.

Procedure:

Equal distance method:

The magnetometer is arranged in tan A position. One of the two given bar magnets of magnetic moment m_1 is placed on one side (Eastern arm) of the two arms with its axis along the east-west direction in the magnetometer. The distance of the magnet is suitably adjusted so that the deflection lies between 30° and 60° . The distance between the centre of the magnet and the centre of the magnetometer is measured as 'd'. The readings of both the ends of the pointer are taken as θ_1 and θ_2 . The magnet is reversed from pole to pole, in the same place and two more readings θ_3 and θ_4 are taken.

The magnet is then kept at the same distance on the other side of the arm (Western arm) and four deflections $\theta_5, \theta_6, \theta_7$ and θ_8 are noted, as mentioned above. The average of the eight deflections is found and taken as θ_1 . The same procedure is repeated with the second magnet of magnetic moment m_{11} , keeping at the same distance and the average deflection θ_{11} is found. The experiment is repeated for different values of d and the readings are tabulated. The ratio of magnetic moments (m_1/m_{11}) is calculated using the formula.

Result:

- i) The magnetic moments of the given two bar magnets are compared.
- ii) The ratio of the magnetic moments of two given bar magnets by equal distance method =

Tan A position:

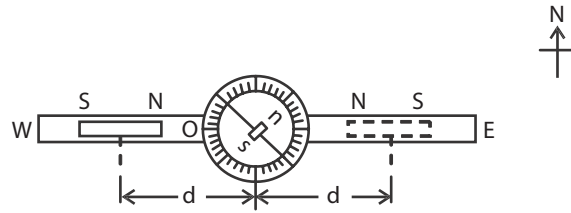

Equal distance method.

To find $\frac{m_1}{m_{11}}$ by equal distance method

Distance d	Magnetic Moment	Deflection in degrees								Mean θ	$\frac{m_1}{m_{11}} = \frac{\tan \theta_1}{\tan \theta_{11}}$
		Eastern arm				Western arm					
		Direct		Reversed		Direct		Reversed			
		θ_1	θ_2	θ_3	θ_4	θ_5	θ_6	θ_7	θ_8		
	m_1									$\theta_1 =$	
	m_{11}									$\theta_{11} =$	
	m_1									$\theta_1 =$	
	m_{11}									$\theta_{11} =$	
	m_1									$\theta_1 =$	
	m_{11}									$\theta_{11} =$	
	m_1									$\theta_1 =$	
	m_{11}									$\theta_{11} =$	

Average of $\frac{m_1}{m_{11}} =$

Calculation:

a) $d =$ cm
 $\frac{m_1}{m_{11}} = \frac{\tan \theta_1}{\tan \theta_{11}}$

b) $d =$ cm
 $\frac{m_1}{m_{11}} = \frac{\tan \theta_1}{\tan \theta_{11}}$

c) $d =$ cm
 $\frac{m_1}{m_{11}} = \frac{\tan \theta_1}{\tan \theta_{11}}$

d) $d =$ cm
 $\frac{m_1}{m_{11}} = \frac{\tan \theta_1}{\tan \theta_{11}}$

MODEL QUESTION PAPER

1. Measure the thickness of the given irregular glass plate using micrometer. Determine the area of the glass plate using a graph sheet and calculate the volume of the glass plate.
2. Measure the length and diameter of the given solid cylinder using vernier calipers and then calculate the volume of the solid cylinder.
3. Verify the parallelogram law of forces and Lami's theorem using concurrent forces.
4. Determine the comparison of coefficient of viscosities of two liquid by capillary flow method
5. Determine the coefficient of viscosity of a high viscous liquid by Stokes' method.
6. Determine the surface tension of water by capillary rise method.
7. Determine the frequency of the given tuning fork using sonometer.
8. Compare the magnetic moments of the two bar magnets using deflection magnetometer in Tan-A position, by equal distance method.

NOTES

www.padeepz.net

UNIT

1

HEAT

1.1 TRANSFER OF HEAT

Introduction:

Heat is a form of energy, which is responsible for the hot condition or the cold condition of a body. Since it is a form of energy, the quantity of heat is measured in 'joule' with symbol 'J'.

We can realize the hotness or coldness of a body by our sense of touch. But there should be a method to determine the degree of hotness or coldness.

Temperature is a measure of the relative degree of hotness or coldness of the body. For quantitative measurement of temperature some standard temperatures are required, which can be easily reproduced in any laboratory. Generally, we take the melting point of ice as lower fixed point and the boiling point of water (steam point) as upper fixed point.

To measure the temperature, different scales are in use.

1. Centigrade scale :

In this scale, the temperature is measured in 'degree Celsius' with symbol °C. In this scale, the lower fixed point is taken as 0 °C for ice point and the upper fixed point is taken as 100° C for steam point.

2. Fahrenheit scale :

In this scale, the temperature is measured in 'degree Fahrenheit' with symbol °F. Here, the lower fixed point (ice point) is taken as 32 °F and the upper fixed point (steam point) is taken as 212 °F.

3. Absolute scale or Kelvin scale:

In this scale, the temperature is measured by the unit 'kelvin' with symbol 'K'. Usually, the temperatures are measured in centigrade scale in laboratories. To convert the temperature from centigrade scale to Kelvin scale, we have to add 273.15, because 0 K corresponds to -273.15 °C.

$$\begin{aligned} \text{Ex: The room temperature} &= 32^\circ \text{C} \\ &= (32 + 273.15) \text{K} = 305.15 \text{K} \end{aligned}$$

The relation between Celsius 'C', Kelvin 'K' and Fahrenheit 'F' is

$$\frac{C}{100} = \frac{F - 32}{180} = \frac{K - 273}{100}$$

Heat Transfer :

There are three methods of transfer of heat from one place to another. They are Conduction, Convection and Radiation. Conduction takes place both in solids and fluids. Convection cannot occur in solids. Radiation does not require the presence of any medium.

Conduction:

In Conduction, the molecules of the body are responsible for the heat transfer. Here there is no actual movement of molecules from one place to another place. When a rod is heated at one end, the molecules at the hot end vibrate about their mean position and transfer the heat energy to the neighbouring molecules and thus the heat energy reaches the other end of the rod.

Conduction is the process by which heat is transmitted from one point to another without the actual movement of the particles from their equilibrium positions. Conduction takes place in solids, liquids and gases.

Coefficient of thermal conductivity:

Let us consider a metallic rod of cross sectional area A . Let the two ends be separated by a distance d , maintained at temperatures θ_1 and θ_2 . Let θ_1 be greater than θ_2 . Heat flows from the end at the higher temperature to the end at the lower temperature.

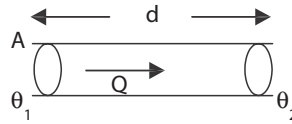

When the steady state is reached, the quantity of heat Q conducted is

- directly proportional to the area of cross section A
- directly proportional to the difference in temperature between the ends $(\theta_1 - \theta_2)$
- directly proportional to the time for which the heat is conducted (t)
- and inversely proportional to the distance between the two ends.

$$\text{Hence } Q \propto A \frac{(\theta_1 - \theta_2)t}{d}$$

or

$$Q = \lambda A \frac{(\theta_1 - \theta_2)t}{d}$$

where λ is a constant known as the coefficient of thermal conductivity of the material and $(\theta_1 - \theta_2)/d$ is known as temperature gradient.

$$\text{when } A = 1, \quad \frac{(\theta_1 - \theta_2)}{d} = 1 \quad \text{and } t = 1, \quad \text{then } Q = \lambda$$

Hence, Coefficient of thermal conductivity (λ) of the material of a conductor is defined as the quantity of heat conducted per second per unit area per unit temperature gradient at the steady state.
unit of λ :

$$Q = \lambda A \frac{(\theta_1 - \theta_2)t}{d} \quad \text{or}$$

$$\lambda = \frac{Qd}{A(\theta_1 - \theta_2)t}$$

Substituting the units,

$$\text{Unit of } \lambda = \frac{\text{Jm}}{\text{m}^2 \text{Ks}} = \text{Js}^{-1} \text{m}^{-1} \text{K}^{-1} = \text{Wm}^{-1} \text{K}^{-1} \quad (\text{as } \text{Js}^{-1} \text{ is } \text{W})$$

Good and poor thermal conductors:-

Substance	λ ($\text{Wm}^{-1} \text{K}^{-1}$)	Substance	λ ($\text{Wm}^{-1} \text{K}^{-1}$)
Silver	420	Water	0.6
Copper	390	Red brick	0.6
Aluminium	240	Rubber	0.5
Steel	14	Wood	0.04 to 0.1
Lead	35	Glass	0.8
Concrete	1.1	Ebonite	0.2

We require both good and poor thermal conductors according to the need. Materials having higher values of coefficient of thermal conductivity are termed as good thermal conductors and the materials having lower values of coefficient of thermal conductivity are called as poor thermal conductors or insulators. The presence of free electrons in metals helps the easy transfer of heat from one part of the metal to the other part. So, all metals are good thermal conductors of heat. Some important materials and their values of coefficient of thermal conductivity are listed above.

Uses of thermal conductors:-

1. Handles made of wood or ebonite are provided for cookers and hot water vessels.
2. Hot water bottles made of rubber are able to keep hot water at high temperature for a considerable period of time.
3. Use of double windows with a thin layer of air enclosed in between them keep the room warm in cold countries.
4. Wool, cork and ebonite are used for the purpose of heat insulation in refrigeration.
5. Woolen clothes are used in winter to keep the body warm.
6. Sawdust and jute sheet is used to cover ice to prevent it from melting.
7. Vessels made of copper, aluminum, etc., are used for cooking purpose as they easily conduct heat.
8. Copper is used in boilers and radiators, because of its good conductivity.

Convection:-

In the case of heat transfer by convection, there is actual movement or motion of molecules of the fluid (liquid or gas).The portions of the fluid that get warmed up by contact with the heat source, expand and so move up through the body of the fluid due to the decrease in density. There is an inflow of cooler molecules to take the place of heated mass of the fluid which has moved up. This circulatory motion of the fluid mass by which heat is transferred from place to place is called Convection.

Convection is the process in which heat is transmitted from one place to the other by the actual movement of heated particles.

Convection takes place only in liquids and gases. It cannot take place in solids.

Applications of Convection.

1. The wind flow is due to the convection currents in the atmosphere. During day time, parts of earth get heated by the Sun. As the air expands, it rises up and its place is taken by the flow of air from colder areas.
2. The land breeze and sea breeze are due to the convection in the atmosphere. During day time, land mass is heated to a higher level than the sea. So, the warm air over the land rises giving place to the cool air flow from the ocean. This gives the sea breeze. During night time, the land mass cools quickly than the water in the sea. So, cool air flows from land mass towards sea which gives the land breeze.

Radiation:-

For heat transfer by radiation, no medium is required. The heat from the Sun is received by earth only by radiation. Both heat and light travel through space with same velocity and they are similar in nature. Both are generated and transmitted in the same way. They are transverse waves and electromagnetic in character, but they differ in wavelength and frequency. The thermal radiations are detected in the 'infra-red" region of the electro-magnetic spectrum.

Radiation is the process by which heat energy is transmitted from one place to another without the aid of an intervening material medium.

Properties of thermal radiation :

The nature of thermal radiation is similar to that of light. Following are some of the properties of thermal radiation.

1. Thermal radiation travels with the velocity of light, which is $3 \times 10^8 \text{ ms}^{-1}$.
2. Thermal radiation obeys the same laws of reflection, refraction etc., as light.
3. Thermal radiation travels through vacuum.
4. It obeys the law of inverse square, as light.
5. It travels in straight lines.
6. When thermal radiation falls on any body, which can absorb it, then converted into ordinary heat, which raises its temperature.
7. It is absorbed by dark rough surfaces and reflected by light smooth surface.

Applications of Radiation.

1. White coloured dresses are used in hot countries to keep the inside cool.
2. In some countries, shining aluminium sheets are used to cover the roof of the house to reflect back the radiant heat and to keep the inside cool.
3. A cooking vessel is painted black at the bottom for greater absorption of heat, but polished at the top to minimize radiation losses.
4. In cold countries, hot air or water runs through the pipes along the walls inside a building and the radiant heat energy keeps the occupants warm by 'Central Heating'.

1.2 KINETIC THEORY OF GASES

A gas consists of a large number of particles called molecules. The molecules are in the state of continuous motion. The pressure of a gas is due to the collision of individual molecules on the walls of the container. The behaviour of the gas can be explained on the basis of kinetic theory of gases. The kinetic theory of gases has found better applications to explain various properties of gases. This theory was developed by Clausius, Boltzmann and Maxwell

1. Postulates of Kinetic Theory of gases:-

1. A gas consists of large number of tiny, rigid particles called molecules.
2. The gas molecules are identical in all respects, like mass, size, etc.
3. The molecules are perfectly elastic spheres.
4. The molecules are in random motion and travel with all possible velocities in all possible directions.
5. The molecules collide with each other and also with the walls of the container.
6. Between two successive collisions, the molecules travel in the straight line.
7. The average distance between two successive collisions is called the mean free path.
8. The time of collision is negligible when compared to the time taken by the molecule to travel its mean free path.
9. The volume of the molecules is negligible when compared to the volume of the gas.
10. The force of attraction between the molecules is negligible.
11. As the molecules of a gas are always in random motion, the energy of the gas is in the form of kinetic energy and it is directly proportional to the absolute temperature of the gas. When the temperature of the gas remains constant, the molecular velocities will not change.

Mean square velocity and Root Mean Square velocity (R.M.S. velocity) :-

Let C_1, C_2, C_3, C_4 be the velocities of 1st, 2nd, 3rdnth molecule present in the gas, then the mean square velocity is,

$$\overline{C^2} = \frac{C_1^2 + C_2^2 + C_3^2 + \dots + C_n^2}{n}$$

The mean square velocity is defined as the average of the square of velocities of all the molecules.

Now R.M.S. velocity is obtained by taking square root of the mean square velocity of the molecules. R.M.S velocity is

$$\sqrt{\overline{C^2}} = \sqrt{\frac{C_1^2 + C_2^2 + C_3^2 + \dots + C_n^2}{n}}$$

The R.M.S. velocity is defined as the square root of the average of squares of velocities of all molecules

Expression for the pressure of a gas :-

Consider a cubical vessel of side one metre containing a perfect gas. The gas contains n-number of molecules and m be the mass of each molecule. The molecules are in continuous motion and they collide with the wall of the container. The force experienced by the wall per unit area, due to the molecular collision gives the pressure of the gas.

$$\text{Pressure} = \frac{\text{Force}}{\text{Area}}$$

Consider a single molecule moving in the X-direction with velocity v. It collides with the wall BCGF of the container and then it rebounds with velocity -v.

- The momentum of the molecule before collision = mv
- The momentum of the molecule after collision = -mv
- ∴ The change in momentum for single molecule = mv - (-mv)
- = 2mv.

After recoil from the wall BCGF, the molecule travels towards the wall AEHD and collide then rebound back to the wall BCGF. So, the molecule travels 2 metre (1m + 1m) for every next collision on the same wall.

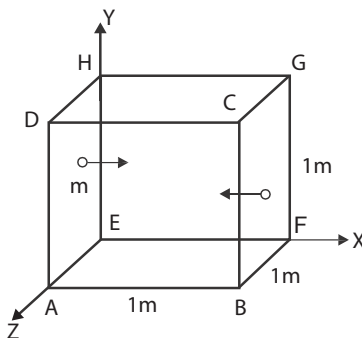

$$\left. \begin{array}{l} \text{Time required to travel} \\ 2m \text{ for next collision} \end{array} \right\} t = \text{distance} / \text{velocity} = 2 / v \text{ second}$$

The rate of change in momentum = change in momentum/ time taken

$$= \frac{2mv}{2/v} = mv^2$$

According to Newton's second law of motion,

Force = Rate of change in momentum.

∴ Force acting on the wall due to 1 molecule = mv^2

An average $n/3$ molecules can be considered to move in each of the three directions X, Y and Z.

$$\begin{aligned} \text{The force acting on the wall due to } n/3 \text{ molecules} &= n/3 (mv^2) \\ \text{Pressure on the wall} &= \text{Force} / \text{Area} \\ &= \frac{(n/3)mv^2}{1} \end{aligned}$$

{Since the area of any side $A = 1 \times 1 = 1 \text{ m}^2$ }

Since the pressure will be the same on all sides,

Pressure of the gas $P = (1/3)nmv^2$

But all the molecules are not moving with the same velocity v .

Let $C_1, C_2, C_3, \dots, C_n$ be the velocities of the molecules,

The mean square velocity $\overline{C^2} = (C_1^2 + C_2^2 + C_3^2 + \dots + C_n^2) / n$

Substituting this average square of the velocity $\overline{C^2}$ for v^2

$$\text{Then, Pressure of the gas } P = \frac{1}{3}nm\overline{C^2}$$

As we have taken m as the mass of each molecule and there are n molecules in the gas,

The total mass of the gas present in the vessel of 1 m^3 volume = nm .

But, mass per unit volume of the gas = $nm = \rho$ the density of the gas.

$$\therefore \text{Pressure of the gas } P = \frac{1}{3}\rho\overline{C^2}$$

Relation between Pressure and kinetic Energy of a Gas:

Consider a perfect gas having unit volume with density ρ and $\overline{C^2}$ be the mean square velocity of gas molecules, then

$$\therefore \text{pressure of the gas } \rho = \frac{1}{3}P\overline{C^2}$$

$$\therefore \text{The Pressure, } P = \frac{1}{3}M\overline{C^2}$$

$$\text{The density } \rho = \frac{M}{V} = M \text{ \{Since volume } V=1 \text{ m}^3\}$$

Dividing and multiplying by 2,

$$P = \frac{2}{2} \times \frac{1}{3}M\overline{C^2} = \frac{2}{3} \times \frac{1}{2}M\overline{C^2}$$

The mean Kinetic energy per unit volume of the gas

$$\text{K.E.} = \frac{1}{2}M\overline{C^2}$$

$$\text{The Pressure } P = \frac{2}{3} \text{ K.E}$$

The pressure of a gas is equal to two third of the mean kinetic energy per unit volume of the gas.

But, the mean square velocity of the molecules $\overline{C^2}$ is directly proportional to the absolute temperature of the gas.

Hence, the pressure of a gas is directly proportional to the absolute temperature of the gas.

Worked Problems:

1. Find the r.m.s. velocity of hydrogen molecule at S.T.P. if density of hydrogen is 0.0899 kgm^{-3} at S.T.P.

Given: $\rho = 0.0899 \text{ kgm}^{-3}$; $P = h\rho g$

Known: At S.T.P, $P = 0.76\text{m of Hg} = 0.76 \times 13.6 \times 10^3 \times 9.8$

$$P = \frac{1}{3} \rho \overline{C^2}, \text{ R.M.S. Velocity, } C = \sqrt{3P/\rho}$$

$$\text{R.M.S. Velocity, } C = \sqrt{\frac{3 \times 0.76 \times 13.6 \times 10^3 \times 9.8}{0.0899}} = 1.838 \times 10^3 \text{ ms}^{-1}$$

2. The root mean square velocity of argon gas molecule at S.T.P. is 434ms^{-1} . Find the density of argon gas at S.T.P.

Given: R.M.S. Velocity, $c = 434 \text{ ms}^{-1}$

Known At S.T.P $P = 0.76\text{m of Hg}$

$$P = \frac{1}{3} \rho \overline{C^2}$$

$$\rho = \frac{3P}{C^2}$$

$$\rho = \frac{3 \times 0.76 \times 13.6 \times 10^3 \times 9.8}{434 \times 434} = 1.6133\text{kgm}^{-3}$$

3. Find the temperature at which the root mean square velocity of hydrogen will double its value at S.T.P. pressure remaining constant.

Let t -be the temperature at which the r.m.s. velocity of hydrogen will double its value at S.T.P.

Let C_0 and C_t be the R.M.S Velocity of molecules at S.T.P and at temperature 't' . i.e. $c_t = 2c_0$

$$\text{Known, } c \propto \sqrt{T} \quad C_t \propto \sqrt{(273+t)} \text{ and } C_0 \propto \sqrt{273}$$

$$C_t = 2C_0 = \sqrt{(273+t)}$$

$$2 \times \sqrt{273} = \sqrt{273+t}$$

Squaring both sides

$$4 \times 273 = 273 + t$$

$$\therefore t = 1092 - 273 = 819 \text{ K or } 546^\circ \text{ C}$$

1.3 SPECIFIC HEAT CAPACITY

When a substance is heated, it gains heat and its temperature increases. The quantity of heat gained by different substances is specified in terms of the value known as specific heat capacity.

Specific heat of solid and liquid :

To increase the temperature of a substance, heat energy should be supplied to it. It is found that the quantity of heat energy supplied to the substance (or) taken by the substance (Q) is directly proportional to

- i) the mass of the substance (m) and
- ii) increase in temperature of the substance ($T_2 - T_1$)

where T_1 initial temperature of the substance and T_2 final temperature of the substance.

$$Q \propto m (T_2 - T_1)$$

$$\text{(or) } Q = S m (T_2 - T_1) \quad (1)$$

Where S is the constant of proportionality and is called as the specific heat capacity of the substance.

In equation (1) when $m = 1 \text{ kg}$ and $(T_2 - T_1) = 1 \text{ K}$, then,

$$Q = S$$

\therefore Specific heat capacity of solid or liquid (or substance) is defined as the quantity of heat energy required to increase the temperature of 1 kg of the substance through 1 K.

Unit for specific heat capacity :

We know $Q = Sm (T_2 - T_1)$

$$\therefore S = \frac{Q}{m(T_2 - T_1)}$$

Substituting the respective units in R.H.S, the unit for specific heat capacity is $\frac{\text{joule}}{\text{kilogram-kelvin}}$ with symbol $\text{J kg}^{-1} \text{K}^{-1}$.

For example, the specific heat capacity of water is $4190 \text{ J kg}^{-1} \text{K}^{-1}$. It means, to increase the temperature of 1 kg of water through 1 K, 4190 J of heat energy is required.

Similarly, the specific heat capacity of copper is $385 \text{ J kg}^{-1} \text{K}^{-1}$. It means, to increase the temperature of 1 kg of copper through 1 K, 385 J of heat energy is required.

Specific heat capacities of a gas :

When a solid or liquid is heated, its temperature alone is increased, neglecting the little increase in its volume. But, when a gas is heated, its pressure and volume change in addition to its temperature. So, to study the effect of heating on a gas, we have to keep either the pressure or volume of the gas as constant. Accordingly, for each and every gas, there are two specific heat capacities.

1. Specific heat capacity at constant pressure (C_p) :

The specific heat capacity of a gas at constant pressure is the quantity of heat energy required to increase the temperature of one mole of the gas through 1K, when the pressure is kept constant.

2. Specific heat at constant volume (C_v) :

The specific heat capacity of a gas at constant volume is the quantity of heat energy required to increase the temperature of one mole of the gas through 1K, when the volume is kept constant.

The unit for C_p and C_v is $\text{J K}^{-1} \text{mol}^{-1}$

Ratio of specific heat capacities (γ) :

For a gas, the ratio of the specific heat capacity at constant pressure to the specific heat capacity at constant volume is a constant. i.e.

$$\frac{\text{Specific heat capacity at constant pressure } (C_p)}{\text{Specific heat capacity at constant volume } (C_v)} = \gamma \text{ (constant)}$$

Since C_p is always greater than C_v , the value of γ is always greater than one for any gas.

3. Ratio between C_p and C_v

The ratio of the specific heat capacity of gas at constant pressure to the specific heat capacity of gas at constant volume is a constant and is denoted by the letter (γ)

$$\text{Then, } \gamma = \frac{C_p}{C_v}$$

When a gas is heated at constant volume the heat supplied to the gas is wholly used to raise the temperature of the gas whereas when the gas is heated at constant pressure, a part is used to external work to keep the pressure constant.

For monoatomic gases $\gamma = 5/3$ for diatomic gases, $\gamma = 7/5$ and for triatomic gases $\gamma = 4/3$

Explanation for C_p greater than C_v :

The Specific heat capacity of a gas at constant pressure (C_p) is the heat energy required to increase the temperature of 1 mole of a gas through 1K, at constant pressure.

The Specific heat capacity of a gas at constant volume (C_v) is the heat energy required to increase the temperature of 1 mole of a gas through 1K, at constant volume.

When a gas is heated, keeping the volume of the gas as constant, the entire heat energy supplied is used only to increase its internal energy i.e. temperature.

When a gas is heated, keeping the pressure of the gas as constant, the supplied heat energy is simultaneously used for two purposes. A part of heat energy is used to increase the temperature of the gas and rest of the energy is used to do the external work of pushing the piston up, to maintain the constant pressure. Hence, in this case more heat energy is to be supplied to the gas. Thus C_p is greater than C_v .

Mayer's relation $C_p - C_v = R$ (Relation between C_p and C_v)

Consider 1 mole of a perfect gas inside a cylinder in which there is a tight piston moving without any friction. The internal energy of the gas is directly proportional to its absolute temperature. Let dQ_1 be the heat energy supplied to the gas at constant volume. Consequently, the temperature increases by dT .

We know, quantity of heat supplied =

$$\text{mass} \times \text{specific heat capacity} \times \text{increase in temperature}$$

$$\text{So, } dQ_1 = 1 C_v dT \tag{1}$$

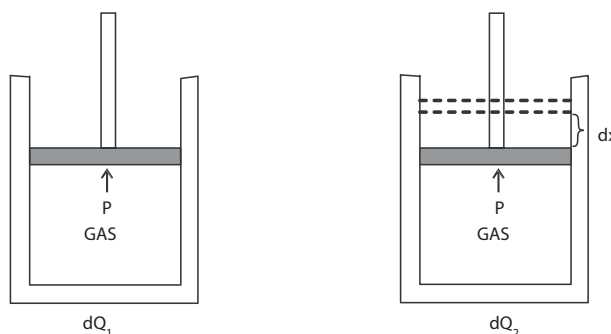

Here, the entire heat is used to increase the temperature of the gas i.e. to increase the internal energy of the gas and no external work is done.

Let us now consider one mole of a perfect gas enclosed in a cylinder as before. Let the pressure and volume of the gas be P and V_1 respectively. Let A be the area of the piston. A quantity of heat dQ_2 be given to the gas at constant pressure, such that the increase in temperature is same dT .

$$\text{Now } dQ_2 = 1 C_p dT \quad (2)$$

As the pressure of the gas is constant, the volume increases to V_2 .

So, some external work is done by the gas on the piston. Here the heat supplied is used for two purposes.

A portion of the heat dQ_2 is used to increase the internal energy and the rest is used to do external work. i.e. dQ_2 is used to

(i) to increase the temperature of the gas by dT . and

(ii) to push the piston up.

$\therefore dQ_2 = dQ_1 + \text{work done in pushing the piston up.}$

$$dQ_2 = dQ_1 + \{ \text{Force} \times \text{displacement of the piston} \} \quad (3)$$

We know that, Pressure = Force / Area

\therefore Force acting on the piston = Pressure \times Area = PA

Let dx be the distance moved by the piston, as shown in fig (ii). Therefore (3) becomes,

$$dQ_2 = dQ_1 + PA dx. \quad \text{But } A dx = dV$$

where $dV = V_2 - V_1$ is the increase in volume of the gas.

$$dQ_2 = dQ_1 + P dV \quad (4)$$

Using (2) & (1), (4) becomes,

$$1 C_p dT = 1 C_v dT + P dV$$

$$C_p dT = C_v dT + P dV$$

$$(C_p - C_v) dT = P dV$$

The equation for a perfect gas is $PV = RT$

On differentiating, $P dV = R dT$

So, the above expression becomes

$$(C_p - C_v) dT = R dT ; \quad (C_p - C_v) = R \frac{dT}{dT} ; \quad \text{But, } \frac{dT}{dT} = 1$$

$$\therefore (C_p - C_v) = R$$

Note: Since value of the Universal gas constant R is positive, the value of C_p is always greater than C_v for any gas.

Value of Universal Gas Constant: (R)

Calculate the value of R from the gas equation $PV = RT$ (OR) Calculate the universal gas constant of given gas, given one gram molecule of at gas at N.T.P. occupies a volume of 22.4 litres.

$$\begin{aligned} \text{AT N.T.P. Pressure } P &= 0.76 \text{ m of Hg} \\ &= 0.76 \times 13.6 \times 10^3 \times 9.8 \end{aligned}$$

$$\begin{aligned} \text{Volume } V &= 22.4 \text{ litres} \\ &= 22.4 \times 10^{-3} \text{ m}^3 \end{aligned}$$

$$\text{Temperature } T = 273 \text{ K}$$

$$\text{Gas equation } PV = RT$$

$$R = PV/T$$

$$= \frac{0.76 \times 13.6 \times 10^3 \times 9.8 \times 22.4 \times 10^{-3}}{273}$$

$$\text{Universal gas constant } R = 8.31 \text{ JK}^{-1} \text{ per gram mole (or) } R = 8310 \text{ JK}^{-1} \text{ per k. mole}$$

Worked Examples:

1. A gas at 1.5 atmospheres occupies a volume of 2m^3 at 25°C . What will be the volume of gas at 40°C and at 3 atmospheres?

$$\text{Gas equation, } PV = RT \text{ (or) } \frac{PV}{T} = R$$

$$\text{Also } \frac{P_1 V_1}{T_1} = \frac{P_2 V_2}{T_2}$$

$$P_1 = 1.5 \text{ Atm.pre.}, T_1 = 25^\circ\text{C} + 273 = 298\text{K}$$

$$P_2 = 3 \text{ Atm.pre.}, T_2 = 40^\circ\text{C} + 273 = 313\text{K}$$

$$\text{And } V_1 = 2 \text{ m}^3$$

$$V_2 = \frac{(P_1 V_1 T_2)}{P_2 T_1} = \frac{(1.5 \times 2 \times 313)}{(3 \times 298)} = 1.05 \text{ m}^3$$

2. The ratio between two specific heats of a gas is 1.36. The specific heat capacity of the gas at constant volume is 23094 JK^{-1} per k. mole. Find the value of Universal gas constant.

$$C_p / C_v = 1.36 \text{ and } C_v = 23094 \text{ JK}^{-1} \text{ per k.mole}$$

$$C_p = 1.36 \times C_v = 1.36 \times 23094 = 31407.84 \text{ JK}^{-1} \text{ per k mole.}$$

$$\text{By Mayers relation } C_p - C_v = R$$

$$\text{i.e., } R = 31407.84 - 23094$$

$$R = 8313.84 \text{ JK}^{-1} \text{ per k. mole}$$

3. Find the specific heat capacity at constant pressure of helium if $C_v = 12525 \text{ JK}^{-1}$ per k. mole. One gram molecule of the gas occupies 22.42 litres at NTP Given $g = 9.8\text{ms}^{-2}$ and density of mercury = 13600 kgm^{-3}

$$\text{Given: } C_v = 12525 \text{ JK}^{-1} \text{ per k. mole}$$

$$V = 22.42 \text{ litres } = 22.42 \times 10^{-3} \text{ m}^3$$

$$\text{At. N.T.P. } P = 0.76 \times 136000 \times 9.8 \text{ and } T = 273 \text{ K}$$

$$\text{Gas equation } PV = RT$$

$$R = \frac{PV}{T} = \frac{0.76 \times 136000 \times 9.8 \times 22.42 \times 10^{-3}}{273}$$

$$= 8.313 \text{ JK}^{-1} \text{ permole}$$

$$= 8313 \text{ JK}^{-1} \text{ k mole}^{-1}$$

$$\text{By Meyer's relation, } C_p - C_v = R$$

$$C_p = R + C_v$$

$$= 8313 + 12525$$

$$\text{i.e., } C_p = 20838 \text{ JK}^{-1} \text{ per k. mole}$$

4. The ratio of two specific heats of Ammonia is 1.31 and universal gas constant is 8314 JK^{-1} per k.mole. Calculate the specific heat of the gas at constant pressure and at constant volume.

$$\text{The ratio, } C_p / C_v = \gamma, C_p = \gamma C_v$$

$$\text{By Meyer's Relation, } C_p - C_v = R, C_p = R + C_v$$

$$\text{Then } R + C_v = \gamma C_v$$

$$R = \gamma C_v - C_v = C_v (\gamma - 1)$$

$$C_v = \frac{R}{(\gamma - 1)} = 8314 / (1.31 - 1)$$

$$\text{i.e., } C_v = 26819 \text{ JK}^{-1} \text{ per k. mole}$$

$$C_p = R + C_v = 8314 + 26819$$

$$\text{i.e., } C_p = 35133 \text{ JK}^{-1} \text{ per k. mole}$$

QUESTIONS

Part -A and Part – B

1. What is Heat?
2. What is temperature?
3. What are the three important scales of temperature?
4. Define Conduction.
5. Define Convection.
6. Define Radiation.
7. Give examples for two good and two poor thermal conductors.
8. Define the coefficient of thermal conductivity.
9. Give the relation between pressure and kinetic energy of a gas.
10. Define mean square velocity of molecules.
11. Define Root Mean Square velocity of molecules.
12. Give the relation between two specific heats of a gas with universal gas constant.
13. State any two postulates of kinetic theory of gases.
14. Define mean free path.
15. Define specific heat capacity of a solid.
16. Define specific heat capacity of a liquid
17. Define specific heat capacity of a gas at constant pressure.
18. Define specific heat capacity of a gas at constant volume
19. Define ratio of specific heat capacities of gases.

Part –C

1. Explain the process of conduction, convection and radiation.
2. Explain the selection and uses of good and poor thermal conductors.
3. List the properties and uses of thermal radiation.
4. List the postulates of kinetic theory of gases.

5. Derive an expression for the pressure of a gas on the basis of Kinetic theory of gases.
6. Derive the relation between pressure and kinetic energy and absolute temperature of a gas.
7. Derive the expression for the mean kinetic energy per molecule of a gas.
8. Derive Meyer's relation between two specific heat capacities C_p and C_v of a perfect gas. (or) Derive $C_p - C_v = R$, for a perfect gas.
9. Calculate the value of universal gas constant from the equation $PV = RT$.

Exercise problems:

1. Find the RMS velocity of hydrogen molecules at S.T.P., if the density of hydrogen is 0.0899 kg m^{-3} at S.T.P. (Ans: 1838.52 m s^{-1})
(Hint: - S.T.P. means standard temperature and pressure Standard pressure = 1 atmospheric pressure = 76 cm of mercury $P = h\rho g = 0.76 \times 13,600 \times 9.81 = 101396.16 \text{ N m}^{-2}$)
2. At atmospheric pressure, the density of Nitrogen gas is 1.25 kg m^{-3} . Find the R.M.S. velocity of Nitrogen molecules. (Ans: 493.05 m s^{-1})
3. The density of carbon dioxide gas at S.T.P. is 1.977 kg m^{-3} . Find the R.M.S. velocity of carbon dioxide molecules. (Ans: 392.05 m s^{-1})
4. Calculate R.M.S. velocity of air molecules at N.T.P., if the density of air is 1.29 kg m^{-3} . (Ans: 485.35 m s^{-1})
5. The density of Helium gas at S.T.P. is 0.1786 kg m^{-3} . Calculate the RMS velocity of Helium molecules. (Ans: 1304.4 m s^{-1})
6. The molecular weight of carbon di-oxide is 44. Calculate the RMS velocity of CO_2 molecules at N.T.P. (Ans: 393.32 m s^{-1})
7. The specific heat capacity of a gas at constant volume is $23,094 \text{ J K}^{-1} \text{ k mol}^{-1}$. The ratio of specific heat capacities of the gas is 1.36. Calculate the specific heat capacity of the gas at constant pressure and also the value of the universal gas constant R for that gas. (Ans: $8313.84 \text{ J K}^{-1} \text{ k mol}^{-1}$)
8. The specific heat capacity of Helium gas at constant volume is $12,525 \text{ J K}^{-1} \text{ k mol}^{-1}$. Find the specific heat capacity of the gas at constant pressure. 1 gram molecule of the gas occupies 22.4 litres at N.T.P. (Ans: $20836.2 \text{ J K}^{-1} \text{ k mol}^{-1}$)
9. The ratio of specific heat capacities of Helium is 1.667. Calculate its specific heat capacity at constant volume and at constant pressure. Given $R = 8.3151 \text{ J K}^{-1} \text{ mol}^{-1}$. (Ans: $C = 12.430 \text{ J K}^{-1} \text{ mol}^{-1}$ & $C = 20.72 \text{ J K}^{-1} \text{ mol}^{-1}$)
10. Calculate the value of gas constant for nitrogen if its density is 1.251 kg m^{-3} at N.T.P. (Molecular mass of nitrogen is 28g.) (Ans: $R = 8.3048 \text{ JK}^{-1} \text{ mol}^{-1}$)

Brain Teasers:

- 1) Calculate the value of gas constant for hydrogen, given density of hydrogen at NTP is 0.09 kg m^{-3} and molecular mass is 2 g (Ans: $R = 8.140 \text{ J K}^{-1} \text{ mol}^{-1}$)
- 2) The ratio of the specific heats of methane is 1.313. The specific heat capacity at constant pressure is 35200 JK^{-1} per k mole. Calculate the value of specific heat at constant volume and hence calculate the value of gas constant.

(Ans: $C = 26808.8 \text{ JK}^{-1} \text{ k mol}^{-1}$ $R = 8911 \text{ JK}^{-1} \text{ k mol}^{-1}$)

UNIT 2

THERMODYNAMICS, LIQUEFACTION OF GASES & NON-CONVENTIONAL ENERGY

2.1 THERMODYNAMICS

Introduction:

Energy exists in various forms in nature. They are mechanical energy (kinetic and potential), heat energy, electrical energy, radiant energy, chemical energy, etc.

In a hydroelectric power station, mechanical energy is converted into electrical energy. In a steam engine, heat energy is converted into mechanical energy. When a metal piece is hammered mechanical energy is converted into heat energy.

Thermodynamics deals with the conversion of heat energy into mechanical energy and vice versa. But in a mere general sense, it includes the relation of heat to other forms of energy like electrical energy, chemical energy, etc. In our discussions we will be concerned mainly about the conversion of heat energy into mechanical energy.

The science of thermodynamics is guided by the three laws of thermodynamics which will be discussed here.

First Law of Thermodynamics:-

When a certain quantity of heat is supplied to a system, the whole of the heat energy may not be converted into work. Part of the heat may be used in doing external work and the rest of the heat might be used in increasing the internal energy of the molecules. Let the quantity of heat supplied to the system be ΔQ , ΔW is the work done by the system and ΔU is the change in internal energy of the system.

$$\Delta Q = \Delta W + \Delta U$$

Hence the first law of thermodynamics states that the amount of heat energy supplied to a system is equal to the sum of the change in internal energy of the system and the work done by the system.

According to First Law of Thermodynamics, heat energy can be converted into mechanical work and vice versa.

ISOTHERMAL AND ADIABATIC CHANGES:

In general, when a quantity of heat is given to the gas a part of the heat is used to increase the internal energy of the gas and the rest is used to do external work by the gas. Let dQ be the quantity of heat given to the gas, dE the increase in internal energy and W the external workdone by the gas. Then

$$dQ = dE + W$$

This equation is called Gas - energy equation.

Isothermal Change

Any change in the pressure and volume of a gas at constant temperature is called as isothermal change.

Consider a gas inside the cylinder with a piston moving in it without friction. When the gas is compressed slowly, the temperature of the gas increases due to the workdone on the gas. If the cylinder and the piston are madeup of conducting materials then the gas gives out the excess heat to the surroundings. Hence there is no rise in temperature.

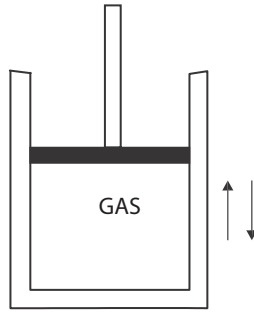

When the piston moves upwards slowly, the gas expands and the temperature of gas decreases due to the work done by the gas. Then the gas gained shortage of heat from the surroundings. Hence the temperature and therefore there is no change in internal energy. The gas- energy equation for Isothermal change becomes,

$$dQ = \text{change in internal energy} + \text{External work for isothermal change, } dQ = 0 + W$$

For a perfect gas, isothermal change can be represented by the equation,

$$PV = \text{a constant} \quad \text{Also} \quad P_1 V_1 = P_2 V_2$$

2. Adiabatic Change :

When the pressure and volume of a gas change, but no heat is allowed to enter or leave the gas, this change. is called as adiabatic change.

Consider a gas inside the cylinder with a piston moving in it without friction. When the gas is compressed suddenly, the temperature of the gas is increased and the work is done on the gas. Similarly when the piston moves upwards suddenly, the temperature of the gas is decreased and work is done by the gas. Due to the sudden compression or expansion, the gas neither gives out heat to the surroundings nor receives heat from the surroundings, when the cylinder and the piston are made up of non conducting materials.

During the adiabatic change, no heat leaves or enters the gas. That is $dQ = 0$. The work is done at the cost of internal energy. The gas energy equation, for the adiabatic change becomes,

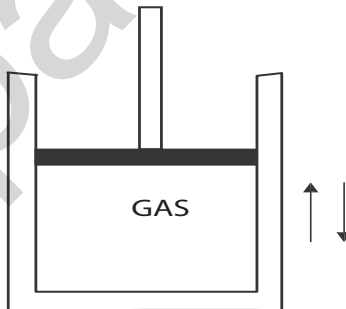

$$dQ = \text{Change in internal energy} + \text{External work}$$

For a perfect gas, adiabatic change can be represented by the equation,

$$PV^\gamma = \text{a constant} \quad \text{Also} \quad P_1 V_1^\gamma = P_2 V_2^\gamma$$

The equation relating the temperature and volume of the gas is $T_1 V_1^{\gamma-1} = T_2 V_2^{\gamma-1}$

The equation relating the temperature and pressure of the gas is $T_1^\gamma P_1^{1-\gamma} = T_2^\gamma P_2^{1-\gamma}$

Where $\gamma = C_p / C_v$ is the ratio of the two specific heat capacities of the gas.

3. Worked Problems:

1. A gas at 2 ATP is compressed to half of its original volume. Calculate the final pressure, if the compression is (i) isothermal and (ii) adiabatic ($\gamma = 1.4$)

Let V be the original volume

Given; $P_1 = 2$ atmosphere, $V_1 = V$ and $V_2 = \frac{1}{2} V$

1) For Isothermal change, the equation is $P_1 V_1 = P_2 V_2$

$$\therefore P_2 = \frac{P_1 V_1}{V_2} = \frac{2 \times V}{(1/2)V} = 4 \text{ atmospheric pressure}$$

ii) Adiabatic equation is $P_1 V_1^\gamma = P_2 V_2^\gamma$

$$\begin{aligned} \therefore P_2 &= \frac{P_1 V_1^\gamma}{V_2^\gamma} = \frac{2 \times V^\gamma}{\left(\frac{V}{2}\right)^\gamma} = \frac{2 \times V^\gamma \times 2^\gamma}{V^\gamma} \\ &= 2 \times 2^\gamma = 2 \times 2^{1.4} \\ &= 2 \times 2^{1.4} = 5.278 \text{ Atmospheric Pressure.} \end{aligned}$$

2. Air at a pressure of 0.75 m of mercury and of volume 1 litre is compressed to a pressure of 1.5 m of mercury under isothermal process. Calculate the resulting volume.

The equation for Isothermal change is $P_1 V_1 = P_2 V_2$

Given; $P_1 = 0.75\text{m of Hg}$

$P_2 = 1.5\text{m of Hg}$

$V_1 = 1 \text{ litre}$

$$\therefore V_2 = (P_1 V_1) / P_2 = (0.75 \times 1) / 1.5 = 0.5 \text{ litre}$$

3. A certain mass of gas at 3 atmosphere is compressed adiabatically to half of its volume. Calculate the resulting pressure if $\gamma = 1.4$

Given; $V_1 = V$, $V_2 = \frac{1}{2} V$ and $P_1 = 3$ atmosphere pressure

$$P_2 = P_1 V_1^\gamma / V_2^\gamma$$

$$P_2 = P_1 V^\gamma / (\frac{1}{2} V)^\gamma$$

$$P_2 = (3 \times V^{1.4}) / (\frac{1}{2} V)^{1.4} = 3 \times 2^{1.4} = 7.92 \text{ atmosphere pressure}$$

Second Law of Thermodynamics:-

A heat engine is mainly used for the conversion of heat energy into mechanical work. A refrigerator is a device used to cool a certain space below the temperature of its surroundings. The first law does not contradict the existence of 100% efficient heat engine or a refrigerator, which are not attainable in practice. These phenomena led to the formulation of second law of thermodynamics. There are two versions of this second law of thermodynamics.

a. Clausius Statement :

It is impossible for a self acting mechanism working in a cyclic process unaided by an external agency to transfer heat from a body at a lower temperature to the body at a higher temperature.

This part of the law is applicable in the case of ice plants and refrigerators. i.e., Heat itself cannot flow from a body at a lower temperature to a body at a higher temperature, on its own.

b. Kelvin's Statement:

It is impossible to derive a continuous supply of work from a body by cooling it to a temperature lower than that of its surroundings. This part of the law is applicable in the case of Heat engines. In a heat engine the working substance does some work and rejects the remaining heat to the sink. The temperature of the source must be higher than the surroundings. The engine will not work when the temperatures of the source and the sink are same.

Carnot's Engine:

The Carnot Engine is an ideal engine, operating between a source and a sink is free from friction and the other imperfections of actual engines. Which absorbs all its heat at a constant high temperature, works in a cycle of operations which is perfectly reversible and rejects remaining heat at constant low temperature.

A Carnot's Engine consists of the following parts.

1. Source:

A source is a hot body at a constant temperature T_1 K. The heat engine can draw heat from the source.

2. Sink:

This sink is a cold body at constant temperature T_2 K in which any amount of heat can be rejected.

3. Working substance:

The working substance is an ideal gas enclosed in a cylinder piston arrangement. The cylinder has perfectly non-conducting walls but a perfectly conducting bottom fitted with a perfectly non conducting and frictionless piston.

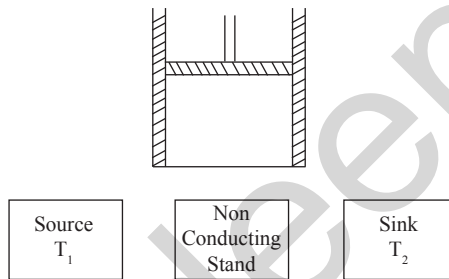

A perfectly non-conducting stand is provided so that the working substance can undergo adiabatic processes.

Working of Carnot Engine (Carnot's Cycle):

The Carnot's Engine is based on a reversible cycle of four operations.

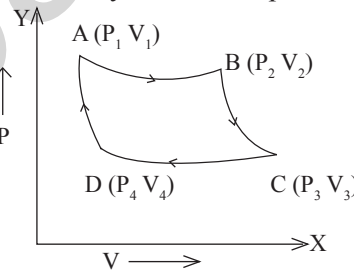

Pressure Volume Indicator diagram

1. The working substance is placed on the source (T_1). Now the gas expands isothermally. In this process gas does work on the piston whence its temperature falls which is immediately taken from the source. The pressure of gas decreases from P_1 to P_2 and volume of gas increases from V_1 to V_2 . This isothermal expansion of gas at constant temperature T_1 is represented by AB on the indicator diagram.
2. The cylinder is removed from the source and placed over the insulating stand. Now, the gas is thermally isolated and allowed to undergo an adiabatic expansion at the expense of its internal energy till temperature falls to T_2 . In this adiabatic expansion pressure and volume of gas change from P_2, V_2 to P_3, V_3 which is represented by BC of the indicator diagram.

- The working substance at C is unable to perform work (P_3 very low) hence it is brought back to the initial state A. For this cylinder is kept on the sink and the piston is moved down so that the gas is compressed from P_3, V_3 to P_4, V_4 . Heat produced due to compression passes to the sink. This isothermal process is represented by CD of the PV diagram. Here, work done is equal to the Heat rejected.
- At this stage D, the cylinder is again kept over the insulating stand and compressed adiabatically so that the initial state is attained.

Efficiency:

The efficiency of the Carnot's engine depends on the temperature of the source (T_1) and the temperature of the sink (T_2).

$$\text{Efficiency } \eta = 1 - \frac{T_2}{T_1} \quad \eta = \frac{\text{Output}}{\text{Input}} = \frac{\text{Heat Converted into Work}}{\text{Heat received from the Source}}$$

2.2. LIQUEFACTION OF GASES

The work on the liquefaction of gases started in 1823 by Faraday. Gases like chlorine, hydrogen chloride, hydrogen sulphide, sulphur dioxide, ammonia and carbon dioxide were liquefied under high pressure with the aid of simple freezing mixtures. But this method cannot be used to liquefy oxygen, nitrogen, hydrogen and helium.

In 1863, Andrews had discovered the phenomenon of critical state of the gas. According to Andrew's discovery, a gas cannot be liquefied when it is at above a particular temperature. That particular temperature is called critical temperature. The pressure and volume of the gas corresponding to that temperature are called the critical pressure and critical volume. After Andrew's discovery, the liquefaction was done easily by cooling the gas below its critical temperature, even though the process is difficult to liquefy oxygen, nitrogen, hydrogen and helium since they have very low critical temperatures. For example, the critical temperature for oxygen is -119°C and for hydrogen is -240°C .

Then in 1877, Pictet liquefied the oxygen by cascade (step by step) process in which low temperatures are obtained in step by step by the evaporation of suitable liquids. In 1896, Linde performed a process to liquefy air by using Joule - Thomson effect.

Critical constants:

The critical temperature, critical pressure and critical volume are called critical constants T_c

1. Critical Temperature (T_c): The critical temperature of gas is defined as that temperature above which the gas cannot be liquefied however great the pressure applied may be.

2. Critical pressure (P_c): The critical pressure is the minimum pressure required to liquefy a gas when it is at its critical temperature.

3. Critical volume (V_c): The critical volume is the volume of unit mass of a gas when it is at its critical temperature and critical pressure.

Note: Below the critical temperature the gas is termed as vapour and above the critical temperature it is termed as gas. The gas can be liquefied easily when it is in the state of vapour. Gases like oxygen, nitrogen, hydrogen and helium are termed as permanent gases since they have very low critical temperatures.

2. Cascade Process - Liquefaction of oxygen:

The critical temperatures for oxygen -119°C and critical pressure is 49.7 atm .

Principle: When a liquid is allowed to evaporate under reduced pressure, it produces high cooling.

The apparatus arrangement used in this process is shown in the figure. It consists of three narrow tubes, A, B and C enclosed by three outer jackets P, Q and R respectively. The narrow tubes and the outer jackets are linked with the compression pumps P_1 , P_2 and P_3 as shown in the figure. The methyl chloride gas of critical temperature 145°C is compressed by the pump P_1 through the tube A. It is cooled by the cold water circulating in the jacket P. Here the methyl chloride reaches the temperature lower than its critical temperature. Then it is liquefied under high pressure. The liquid methyl chloride is collected in the jacket Q and evaporates under reduced pressure lowering the temperature to -90°C .

The ethylene gas of critical temperature 10°C is compressed by the pump P_2 through the tube B. It is cooled to -90°C by liquid methyl chloride. Then it is liquefied under high pressure. The liquid ethylene is collected in the jacket R and evaporates under reduced pressure lowering the temperature to -160°C .

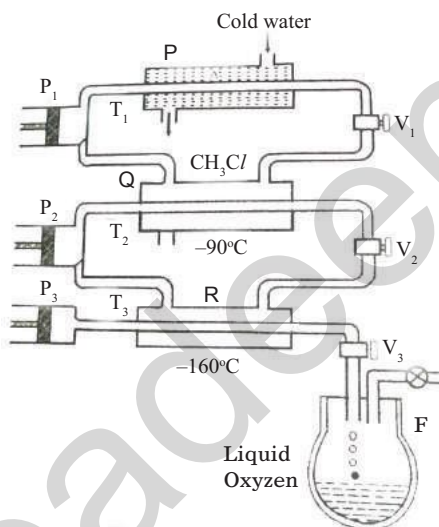

The oxygen gas of critical temperature -119°C is compressed to 50 atmospheric pressure by the pump P_3 and passed through the tube C. It is cooled to -160°C by liquid ethylene in R. Then it is liquefied and the liquid oxygen is collected in the Dewar flask D.

Disadvantage: The lowest temperature obtained in this process is -160°C . Therefore the cascade process cannot be used to liquefy hydrogen and helium whose critical temperatures are lower than -160°C .

3. Joule - Thompson Effect:

Using the principle of Joule - Thompson effect, air, hydrogen and helium were also liquefied. Joule performed an experiment to study the effect of change in the temperature of a gas when it is allowed to pass through a porous plug from the high pressure side to the low pressure side.

Joule - Thompson effect : When a gas is allowed to expand from a high pressure side to a low pressure side through a porous or nozzle or jet then it produces intense cooling, if the temperature of the gas is less than the temperature of inversion. This effect is called Joule - Thompson effect.

Temperature of inversion : If a gas is at a particular temperature no cooling or heating is observed when it is passed through the porous plug. If the temperature of the gas on the high pressure side is more than that temperature, heating will take place instead of cooling. That particular temperature is called the temperature of inversion.

Temperature of inversion may be defined as the temperature at which there is neither cooling nor heating due to Joule Thomson effect.

4. Linde's Process - Liquefaction of Air:

The principle of Joule - Thompson effect is used in this process. The apparatus arrangement used in this process is shown in the figure. It consists of two compressors C_1 and C_2 , a cold water jacket, freezing mixture jacket, narrow tube having nozzle N_1 and a wide tube having nozzle N_2 .

Air is compressed to 25 atmospheres by the compressor C_1 . The compressed air is passed through a tube surrounded by a cold water jacket. Again this air is compressed to 200 atmospheres by the compressor C_2 . This compressed air is passed through a spiral tube surrounded by a freezing mixture jacket. Now the air reaches to a temperature of -20°C . This cooled air at high pressure is allowed to expand through a nozzle N_1 and it is further cooled by Joule - Thompson effect. This cooled air is circulated back to the compressor C_2 and is compressed again.

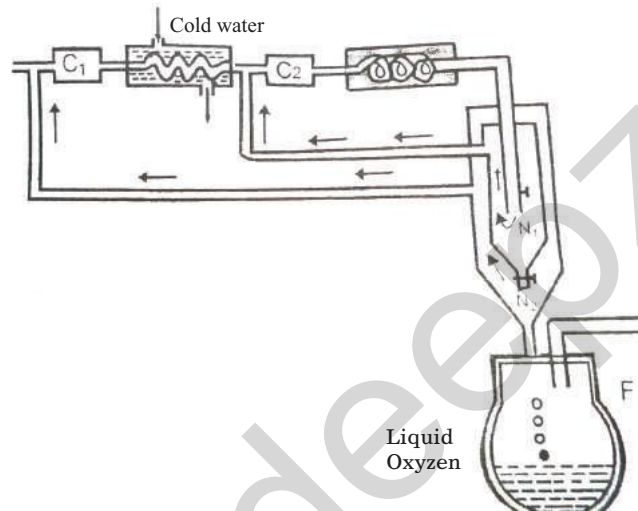

As the process continues, after a few cycles, the air gets cooled to a sufficiently low temperature. Finally the air expands from high pressure side to the low pressure side through the nozzle N_2 . Again the temperature is reduced by Joule - Thompson effect and the air gets liquefied. The liquid air is collected in the Dewar flask. The unliquefied air is again circulated back to the compressor C_1 and the process is repeated. The whole apparatus arrangement is packed in cotton or thermal wool to avoid any conduction and radiation.

2.3 NON CONVENTIONAL ENERGY

Energy is an important input for all sectors of a country's economical development. For India, the energy needs is increasing rapidly day by day. It is a well-known fact that the currently available conventional energy resources like coal, oil, natural gas, etc., are depleting very fast.

54% of our energy need is provided by coal, which may be available for another 80 years at the current rate of usage. 32% of energy need is fulfilled by oil, which may last up to 22 years and the rest 14% is met by hydro, nuclear, natural gas, etc. So, we will have to increasingly depend on other non conventional energy resources like solar, wind, tidal, geothermal, hot dry rock, bio mass, etc.

The sources of energy utilised by human beings fall into two categories:

1. Non-renewable energy resources are sources of power that cannot be replaced once they are used, because the energy source has taken millions of years to form (ex. coal, oil). These energy resources are also called as finite energy resources.

2. Renewable energy resources are sources of power that quickly replenish (fill again) themselves and can be used again and again repeatedly (ex. Wind, tidal). These energy resources are also called as infinite energy resources.

Conventional or Non – renewable sources of energy:

The conventional or non – renewable energy sources are classified as primary and secondary energy sources. The primary energy sources are which provide a net supply of energy, like coal, oil, natural gas, uranium, etc. These fuels are called primary fuels, from which the energy yield ratio is very high. i.e., the energy required to obtain these fuels is much less than what they can produce by combustion or nuclear reaction. The secondary fuels like wood, animal wastes, agricultural wastes, etc., produce no net energy.

Non – conventional or renewable sources of energy:

To meet our future energy requirements, we have to tap other available non conventional or renewable energy sources. The renewable sources of energy are also called as non conventional (or) alternate sources of energy. They are Solar, Wind, Tidal, Geothermal, Bio mass, Hot dry rock, Chemical, etc. Various technologies are designed and developed to tap these earth's natural energy resources which are renewable. They are called renewable because, they are available in plenty and freely.

Solar energy:

The sun is a large sphere of very hot gases, the energy being generated by various kinds of nuclear fusion reactions.

Sun gives us 1000 times more power than we need. Therefore, solar energy can be a major source of power. Even if we could tap one thousandth of solar power, that will meet our requirements. But so far it could not be developed on a large scale.

Energy produced and radiated by the sun, which reaches the earth, is termed as “Solar energy”. Energy is radiated by the sun, as electromagnetic waves. Solar energy, received in the form of electro magnetic radiation, can be converted directly or indirectly into other forms of energy, such as heat and electricity, which can be utilised by human being. Since the sun can radiate energy at constant rate for a few billion years, it may be regarded as an inexhaustible source of useful energy.

As India is situated near equator, where sunlight is abundant for a major part of the year, utilising the solar energy to a greater extent is the best option available to us.

Some important applications of solar energy are

(I) Solar water heating, (ii) Heating and cooling of residential buildings, (iii) salt production by evaporation of sea water, (iv) Solar cookers, (v) Solar furnaces, (vi) Solar pumps for water pumping and (vii) Solar electric power generation.

From solar energy electricity can be produced with the help of photovoltaic or solar cells. The solar cells directly generate electricity by photovoltaic process. When the photons from the sun's light is absorbed by special type of semi conducting material they create free electrons.

These free electrons induce higher energy electrons to flow out of the semiconductor. The flow of higher energy electrons in the circuit constitutes the electric current.

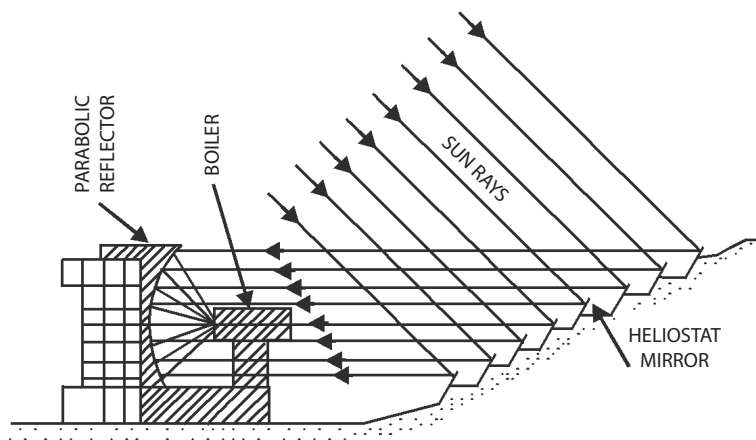

Solar water heating system

This system is used to drive turbo-generators to produce electricity. A plant of this type is operating in France and produces 1000 KW.

2. Wind energy :

Wind is basically caused by the solar energy irradiating the earth. Energy of wind can be economically used for the generation of electrical energy. Wind is caused due to two main factors:

- (a) Due to air in motion. Air motion arises from a pressure gradient. The surface winds flow from the poles toward the equator. Solar radiation heats the air near the equator, and this low density heated air buoyed up. At the surface, it is displaced by cooler, more dense higher pressure air flowing from the poles. In the upper atmosphere near the equator the air tend to flow towards the poles and away from the equator. The net result is a flow of surface winds from north to south in the northern hemisphere. Similarly the flow of surface winds is from south to north in the southern hemisphere of the earth.
- (b) Due to the rotation of the earth with respect to atmosphere, and its motion around the sun.

Wind energy which is an indirect source of solar energy conversion can be utilized to run windmill, which in turn drives a generator to produce electricity. Wind can also be used to provide mechanical power, such as for water pumping.

Some characteristics of wind energy are stated below:

- i) It is a renewable source of energy.
- ii) Wind-power systems are non-polluting, so it does not affect the environment.
- iii) Wind energy systems avoid fuel provision and transport.
- iv) Large areas are needed to install wind forms for electrical power generation and wind energy needs storage means because of its irregularity in the speed of flow.
- v) Manufacture and implementation of wind farms can be costly.

As our country has lot of wind throughout the year, the energy in the wind can be used to generate power that can be used for domestic and industrial uses. The wind mill is the form in which we can convert the wind energy to electricity. The potential of wind energy is of the order of 1.6×10^7 MW.

The wind mill generally consists of a turbine (a dynamo which can produce electricity when rotated) connected to large rotating blades. The blades rotate by using the wind.

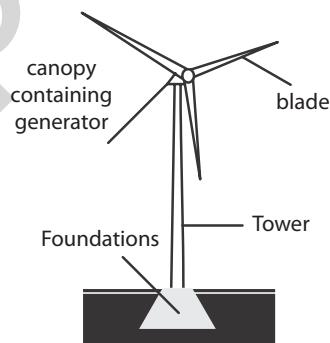

The setting up cost of these windmills is high but the running cost is very low. Use of this would help in producing cheap power. Tamilnadu has set up a large number of wind mills in the state especially in places like Tiruppur, Muppandal in Kanyakumari, Coimbatore and their surroundings.

Advantages of renewable energy:

1. Use of renewable energy resources is less pollutant.
2. Energy from renewable resources can be produced quickly.
3. Several renewable options are financially and economically competitive for certain applications in remote locations, where the costs of transmitting electrical power or transporting conventional fuels are high.

4. The plants which use renewable sources of energy can be built nearer to the site, where energy is needed, and reducing transportation cost of conventional fuels.
5. They can be produced in large numbers and introduced quickly, unlike large power stations which take often 10 years or more to become operational.
6. They can be built on, or close to the site where the energy is required. This minimises the transmission costs.
7. The important advantage is the availability in plenty, almost inexhaustible.

Disadvantages of renewable energy :

1. Even a bad weather can interrupt the supply of electricity produced by wind, tidal, solar energy, etc.
2. The electrical energy produced by these renewable sources has to be stored suitably for continuous reliability.
3. Non existence of a proper planning, policy to finance, nodal agency for implementing renewable energy systems, etc. at the government level.
4. Lack of qualified trained persons to design, manufacture, market, operate and maintain renewable energy sources plants.
5. Inadequate documentation and evaluation of past experience and a lack of clear priorities for future work.

QUESTION

Part – A and Part – B

1. Write First law of thermo dynamics.
2. What is an isothermal change?
3. What is an adiabatic change?
4. Write the Clausius statement of second law of thermo dynamics.
5. Write the Kelvin's statement of second law of thermo dynamics.
6. Define efficiency of Carnot's heat engine.
7. Define Critical temperature.
8. Define Critical pressure.
9. Define Critical volume.
10. What is the difference between a gas and vapour ?
11. What is the principle used in cascade process?
12. What is the disadvantage of cascade process of liquefaction of gases?
13. What is temperature of inversion?
14. What is Joule–Thompson effect?
15. What are the renewable sources of energy?.
16. What are the non-renewable sources of energy?
17. Define conventional energy with examples.
18. Define non-conventional energy with examples.
19. Write any two advantages of Non-conventional sources of energy.
20. Write any two disadvantages of Non–conventional sources of energy.

Part – C

1. Explain isothermal and adiabatic change.
2. Describe the working of Carnot's reversible engine and efficiency with indicator diagram.
3. Describe the cascade process for the liquefaction of oxygen.
4. Describe Linde's process for the liquefaction of air.
5. What are the advantages and disadvantages of non conventional energy over conventional energy?
6. Write a note on solar energy and wind energy.

Exercise Problems:

1. Air at 2 atmospheric pressure is compressed isothermally to one fourth of its original volume. Find the final pressure. [Ans: $P_2 = 8 \text{ At.pr}$]
2. A gas at a pressure of 0.75 m of mercury and volume one litre is compressed slowly to a pressure of 1.5 m of mercury. Find the resulting volume (Ans: 0.5 litre)
3. Air at a pressure of 5 atmosphere is compressed slowly to half of its original volume. Find the resulting pressure. (Ans: 10 atm)
4. A certain mass of gas at 1 atm pressure is suddenly compressed to one-fourth of its original volume. Find the resulting pressure. Given $\gamma = 1.4$ (Ans: 6.964 atm)
5. A certain mass of gas at 50 atm is suddenly expanded to 10 times of its initial volume. Find the resulting pressure. Given $\gamma = 1.4$ (Ans: 1.9905 atm)
6. A gas at 2 atm pressure is compressed to half of its original volume. Calculate the final pressure, if the compression takes place, (i) slowly and (ii) suddenly. Given $\gamma = 1.4$. (Ans: (i) 4 atm (ii) 5.2780 atm)
7. Ten litres of gas at 50 atmospheric pressure is suddenly expanded to 5 atmospheres. Find the resulting volume. Given $\gamma = 1.4$ (Ans: 51.7129 litre)
8. Five litres of a gas at 5 atmospheric pressure is suddenly compresses to a pressure of 5 times the original pressure. Find the resulting volume. Given $\gamma = 1.4$. (Ans: 1.5837litre)

Brain Teasers:

1. The ratio of the specific heat capacities of an ideal gas is 1.4. One atmosphere of the gas is compressed adiabatically to one-fifth of its original volume. Find its final pressure. [Ans: 9.52 At.pr]
2. Air at 5 atmospheres is suddenly compressed to half of its volume. Find the resulting pressure of the air ($\gamma = 1.4$) [Ans: $P_2 = 13.19 \text{ At.pr}$]

UNIT

3

LIGHT AND REMOTE SENSING

LIGHT

Light is a form of energy radiated by luminous bodies. When it enters our eyes, it stimulates the retina to a sense of vision. An object is visible only by the scattering of light from the object reaches the eyes.

The objects which emit light rays (energy) are called light sources. For example, Sun, Stars, lamp etc are the light sources. Light can pass through the transparent medium like glass, air, water etc. Light rays undergo reflection, refraction interference, diffraction, polarization, etc. Light is propagated with a finite velocity $3 \times 10^8 \text{ ms}^{-1}$. Light plays dual role. In some places it behaves like particles and in some places it behaves like waves, traveling in a straight line.

3.1 OPTICS

Refraction

When a ray of light travels from one transparent medium into another medium, it bends while crossing the interface, separating the media. This phenomenon is called refraction.

Laws of Refraction

I Law : The incident ray, the refracted ray and the normal to the refracting surface at the point of incidence are in the same plane.

II law : The ratio of the sine of the angle of incidence to the sine of the angle of refraction is a constant for any two given medium for one particular colour of light. This is known as Snell's law.

Refractive index of a medium

When a ray of light passes from air or vacuum to the given medium, the ratio between the sine of the angle of incidence and the sine of the angle of refraction is called the refractive index of the given medium. If 'i' is the angle of incidence and 'r' is the angle of refraction,

$$\text{Refractive index of the medium } \mu = \frac{\sin i}{\sin r}$$

According to wave theory of light, if 'c' is the velocity of light in air or vacuum and 'v' is the velocity of light in the medium, then

Refractive Index of the medium

$$\mu = \frac{\text{Velocity of light in air (or) vacuum (c)}}{\text{Velocity of light in the medium (v)}}$$

SPECTROMETER

Spectrometer is used to determine the refractive index of the material of the prism and to study spectra.

The three main parts of the spectrometer are Collimator, Prism table and Telescope.

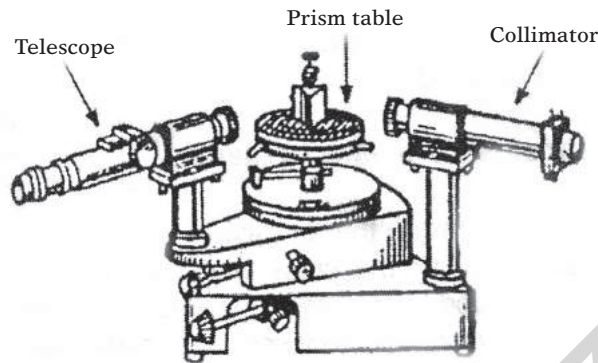

Collimator

The collimator consists of two co-axial brass tubes, one is capable of sliding into the other. An adjustable slit is provided at one end and a convex lens is fixed at the other end of the collimator. The distance between the slit and the convex lens can be changed using the screw provided. The width of the slit can also be changed. The collimator is rigidly fixed to the instrument. It is used to get parallel rays of light.

Prism table

It consists of two circular metal discs with three leveling screws. The prism table can be rotated about an axis passing through its centre. The prism table can be raised or lowered and can be fixed at any desired height. The prism table can be made horizontal by adjusting the levelling screws with the help of a spirit level.

Telescope

It consists of two co-axial brass tubes, one is capable of sliding into the other. An eye-piece is provided at one end and an objective lens is fixed at the other end of the telescope. The telescope can be rotated about the central axis of the instrument. A circular scale graduated in half degree is attached to the telescope. Therefore when the telescope rotates, the circular graduated scale also rotates. The telescope can be fixed in any position using the clamping screw. For fine adjustment of the telescope, the tangential screw is used.

Initial adjustments of a spectrometer

1. The eye-piece in the telescope is gently pulled out or pushed in, till the cross wires are seen clearly.
2. The telescope is turned towards a distant object. Then the distance between the eye-piece and the objective lens of the telescope is adjusted, till the clear image of the object is seen in the field of view of the telescope.
3. The slit is illuminated by a monochromatic source of light. The width of the slit is adjusted suitably by viewing through the convex lens in the collimator. Then the telescope is brought in line with the collimator. Clear image of the slit is obtained by using the screws in the collimator and telescope. Using the tangential screws, the vertical cross wire is made to coincide with the left edge of the image of the slit.
4. The prism table is made horizontal by adjusting the leveling screws in it using a spirit level.

Refraction

When a ray of light passes from one medium to the second its direction changes at the point where it enters the second medium. This phenomenon is known as refraction.

Expression for the refractive index of the material of the prism

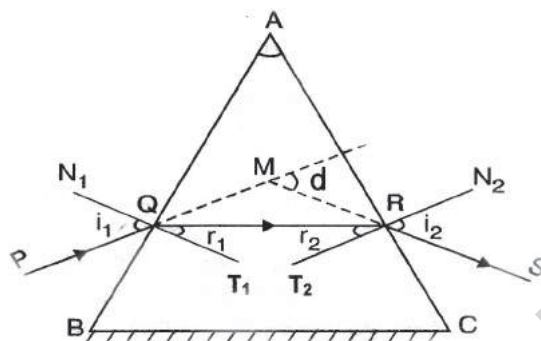

ABC is a glass prism. AB and AC are the refracting faces. BC is the base of the prism. A ray of light PQ is incident on the face AB at angle of incidence i_1 . QR is the refracted ray. The angle of refraction is r_1 . The refracted ray QR is incident on the face AC at an angle of incidence r_2 . RS is the emergent ray. The angle of emergence is i_2 . N_1T_1 and N_2T_2 are the normals drawn to the faces AB and AC at Q and R respectively. By producing PQ and SR the angle of deviation d is obtained.

In ΔAQR ,

$$\angle AQR = 90^\circ - r_1 \text{ and } \angle ARQ = 90^\circ - r_2$$

Again in ΔAQR ,

$$\angle A + \angle AQR + \angle ARQ = 180^\circ$$

$$\text{i.e. } A + (90^\circ - r_1) + (90^\circ - r_2) = 180^\circ$$

$$A - (r_1 + r_2) + 180^\circ = 180^\circ$$

$$A - (r_1 + r_2) = 180^\circ - 180^\circ = 0$$

$$\text{or } A = r_1 + r_2 \dots\dots\dots (1)$$

Here A is the angle of the prism.

$$\text{In } \Delta MQR, \angle MQR = i_1 - r_1 \text{ and } \angle MRQ = i_2 - r_2$$

The exterior angle = sum of interior angles

$$\text{i.e. } d = \angle MQR + \angle MRQ$$

$$\therefore d = i_1 - r_1 + i_2 - r_2 = i_1 + i_2 - (r_1 + r_2)$$

$$d = i_1 + i_2 - A$$

$$\text{i.e. } A + d = i_1 + i_2 \dots\dots\dots (2)$$

As the angle of incidence increases, the angle of deviation decreases to a minimum value and then increases. The minimum value of the angle of deviation is known as the angle of minimum deviation 'D'.

When the deviation is minimum,

$$i_1 = i_2 = i \text{ and } r_1 = r_2 = r$$

Therefore from eqn. (1)

$$A = r + r = 2r$$

$$\therefore r = \frac{A}{2}$$

From equation (2), $A + D = i + i = 2i$

$$\therefore i = \frac{A + D}{2}$$

Refractive index of the glass prism is

$$\mu = \frac{\sin i}{\sin r}$$

$$\therefore \mu = \frac{\sin\left(\frac{A + D}{2}\right)}{\sin\left(\frac{A}{2}\right)}$$

Experiment to determine the refractive index of the material of the prism:

The refractive index of the material of prism is determined by measuring the angle of prism and the angle of minimum deviated ray by using Spectrometer.

Before, starting the experiment the following initial adjustment is made for the spectrometer

1. The telescope is kept in focus by capturing the clear image of distance object.
2. The prism table is kept horizontal by levelling screws in it using spirit level.
3. The slit is illuminated by monochromatic source of light. The collimator screw is adjusted to produce narrow slit. Then, the clear image of the slit is viewed through the telescope and coincide with vertical cross wire of the telescope. Now, the vernier table is adjusted to $0^\circ - 180^\circ$.

Determination of angle of prism A:

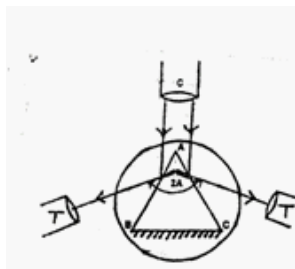

After making initial adjustments, the least count of the spectrometer is determined (as in Vernier Calipers).

Having a very fine slit, the telescope is adjusted for direct ray. A prism is placed on the prism table as shown in the figure. The telescope is turned to catch the reflected image from one polished face AB of the prism. Fixing in that position, the tangential screw is adjusted till the vertical cross wire is made to coincide with the fixed edge of the image of the slit. The readings in the scales I and II are noted.

The telescope is then turned to the other polished face AC of the prism. The readings in the scales I and II are noted when the vertical cross wire coincides with the fixed edge of the image of the slit. The difference between both the scale I readings is $2A$. Similarly the difference between both the scale II readings is $2A$. Then the average of the angle of the prism A is calculated.

Tabular column I:

To determine the angle of the prism A

LC =

Ray	Spectrometer readings in degree							
	Scale I				Scale II			
	MSR	VSC	VSR= VSC \times LC	OR= MSR+VSR	MSR	VSC	VSR= VSC 'LC	OR= MSR+VSR
Reading of the reflected ray (left)				$x_1 =$				$x_3 =$
Reading of the reflected ray (right)				$x_2 =$				$x_4 =$

Determination of angle of minimum deviation:

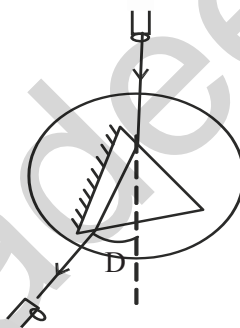

Tabular column II:

To determine the angle of the minimum deviation D

LC =

Ray	Spectrometer readings in degree							
	Scale I				Scale II			
	MSR	VSC	VSR= VSC \times LC	OR= MSR+VSR	MSR	VSC	VSR= VSC 'LC	OR= MSR+VSR
Reading of minimum deviated ray				$d =$				$d =$
Reading of Direct ray				$d =$				$d =$

The prism is placed on the prism table as shown in the figure. The ray of light from the collimator incident on one polished face of the prism gets refracted and emerges out of the other polished face. Viewing the image of the slit through the telescope, the prism table and telescope are rotated simultaneously through small angle such that the image of the slit moves towards the direct ray. At one stage, it is found that the image of the slit is stationary for a moment and on rotating the prism table further in the same direction the image begins to retrace its path. The telescope is fixed at that position, the cross wire is made to coincide with the fixed edge of the image of the slit. At this minimum deviation position, the readings of scales I and II are noted.

The prism is removed from the prism table. The telescope is brought in line with the collimator and the image of the slit is seen through the telescope. The vertical cross wire is made to coincide with the fixed edge of the image of the slit. The readings in the scales I and II are noted.

The difference between the two readings of scale I or scale II gives the angle of minimum deviation D . Hence the refractive index of the material of the prism is calculated using the formula.

The refractive index of the prism is determined by using the formula,

$$\mu = \frac{\sin\left(\frac{A+D}{2}\right)}{\sin\left(\frac{A}{2}\right)}$$

FIBRE OPTICS

Fibre optics deals with the light propagation through thin glass fibres. Fibre optics plays an important role in the modern communication systems. In this system, television voice and digital data signals are transmitted from one place to another place in the form of light waves. The light waves are transmitted along a thin cylindrical glass fibre by using the phenomenon of total internal reflection. It was first demonstrated by John Tyndall in 1870. But in the field of communication it was tried only from 1927. After the discovery of laser beam in 1960, fibre optical communication further developed and extended to medical field.

A bundle of fine fibres is used in the fibre optical communication. The bundle has the advantage of flexibility. A beam entering at one end can be transmitted at the other end through the fibre even though the fibre is curved. The study of such properties of a bundle of fibres is known as fibre optics.

Total Internal Reflection

When a ray of light passes from a denser to a rarer medium, it is bent away from the normal. When the angle of incidence is gradually increased, the corresponding angle of refraction also increases. At a particular angle of incidence, the angle of refraction reaches to 90° . That particular value of angle of incidence is called the critical angle of the medium.

Critical angle is defined as a particular angle of incidence in the denser medium for which the corresponding angle of refraction in the rarer medium is 90° .

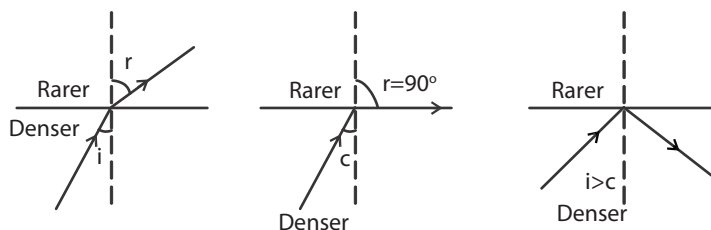

When the angle of incidence is further increased above the critical angle, the ray is totally reflected back in the same denser medium itself. This phenomenon is called total internal reflection.

Two conditions are to be satisfied for total internal reflection.

- 1) Light should travel from denser medium to rarer medium.
- 2) The angle of incidence should be greater than the critical angle of the medium.

According to Snell's law,

$$\mu_r^d = \frac{\sin i}{\sin r}$$

The refractive index of the rarer medium with respect to denser medium,

$$\mu_d^r = \frac{\sin r}{\sin i}$$

Also, the refractive index of the denser medium with respect to rare medium

In critical angle position, $i = c$ and $r = 90^\circ$

$$\therefore \mu_d^r = \frac{\sin r}{\sin i} = \frac{\sin 90^\circ}{\sin c}$$

$$\text{i.e., } \mu_d^r = \frac{1}{\sin C} (\because \sin 90^\circ = 1)$$

The sparkling of the diamond, the phenomenon of mirage and the propagation of light waves along optical fibre are due to the total internal reflection.

Sl.No.	Medium	Refractive index μ w.r.t air	Critical angle : C
1	Water	1.33	48°45'
2	Glass	1.5	41°48'
3	Diamond	2.42	24°24'

SOLVED EXAMPLES

1. Calculate the angle of minimum deviation for an equilateral glass prism of refractive index 1.4.

Refractive index, $\mu = 1.5$

For an equilateral glass prism, $A = 60^\circ$

Angle of minimum deviation, $D = ?$

$$\text{The refractive index, } \mu = \frac{\sin\left(\frac{A+D}{2}\right)}{\sin\left(\frac{A}{2}\right)}$$

$$\sin\left(\frac{A+D}{2}\right) = \mu \times \sin\left(\frac{A}{2}\right) = 1.5 \times \sin\left(\frac{60^\circ}{2}\right)$$

$$\text{i.e. } \sin\left(\frac{A+D}{2}\right) = 1.5 \times \sin 30^\circ = 0.75$$

$$\therefore \frac{A+D}{2} = \sin^{-1}(0.75) = 48^\circ 35'$$

$$A + D = 2 \times 48^\circ 35' = 60^\circ = 37^\circ 10'$$

2. The angle of prism is 60° and a refractive index of its material is 1.512. Calculate the angle of minimum deviation.

Refractive index $\mu = 1.512$

Angle of the prism, $A = 60^\circ$

Angle of minimum deviation, $D = ?$

$$\text{The refractive index, } \mu = \frac{\sin\left(\frac{A+D}{2}\right)}{\sin\left(\frac{A}{2}\right)}$$

$$\sin\left(\frac{A+D}{2}\right) = \mu \times \sin\left(\frac{A}{2}\right) = 1.512 \times \sin\left(\frac{60^\circ}{2}\right)$$

$$\text{i.e. } \sin\left(\frac{A+D}{2}\right) = 1.512 \times \sin 30^\circ = 0.756$$

$$\therefore \frac{A+D}{2} = \sin^{-1}(0.756) = 49^\circ 6'$$

$$A + D = 2 \times 49^\circ 6' = 98^\circ 12'$$

$$D = 98^\circ 12' - A = 98^\circ 12' - 60^\circ = 38^\circ 12'$$

i.e. The angle of minimum deviation $D = 38^\circ 12'$

3. Calculate the refractive index of a prism, if the angle of the prism is 59° and the angle of minimum deviation is 40° .

Angle of the prism, $A = 59^\circ$

Angle of minimum deviation, $D = 40^\circ$

Refractive index, $\mu = ?$

$$\mu = \frac{\sin\left(\frac{A+D}{2}\right)}{\sin\left(\frac{A}{2}\right)} = \frac{\sin\left(\frac{59^\circ + 40^\circ}{2}\right)}{\sin\left(\frac{59^\circ}{2}\right)} = 1.544$$

4. In an experiment the angle of the prism and the angle of minimum deviation were found to be $59^\circ 52'$ and $40^\circ 30'$. Find the refractive index of the material of the prism.

Angle of the prism, $A = 59^\circ 52'$

Angle of minimum deviation, $D = 40^\circ 30'$

Refractive index, $\mu = ?$

$$\mu = \frac{\sin\left(\frac{A+D}{2}\right)}{\sin\left(\frac{A}{2}\right)} = \frac{\sin\left(\frac{59^\circ 52' + 40^\circ 30'}{2}\right)}{\sin\left(\frac{59^\circ 52'}{2}\right)}$$

$$\mu = \frac{\sin 50^\circ 11'}{\sin 29^\circ 56'} = 1.539$$

Refractive index of the material of the prism is 1.539.

5. The minimum deviation produced by a glass prism having an angle of 60° is 30° . If the velocity of light in vacuum is $3 \times 10^8 \text{ ms}^{-1}$, calculate the velocity of light in glass.

$$A = 60^\circ, D = 30^\circ$$

$$\text{Velocity of light in vacuum, } C = 3 \times 10^8 \text{ m s}^{-1}$$

Refractive index of glass, $\mu = ?$

$$\mu = \frac{\sin\left(\frac{A+D}{2}\right)}{\sin\left(\frac{A}{2}\right)}$$

$$\mu = \frac{\sin\left(\frac{60^\circ + 30^\circ}{2}\right)}{\sin\left(\frac{60^\circ}{2}\right)} = \frac{\sin 45^\circ}{\sin 30^\circ} = 1.414$$

Refractive index of glass is

$$\mu = \frac{\text{Velocity of light in air or vacuum (C)}}{\text{Velocity of light in the medium (V)}}$$

$$\text{Velocity of light glass (V)} = \frac{C}{\mu} = \frac{3 \times 10^8}{1.414}$$

$$= 2.122 \times 10^8 \text{ ms}^{-1}$$

3.2 LASER

An atom consists of an electron cloud revolving around the central nucleus having protons and neutrons. The atoms are constantly in motion, they vibrate, move and rotate. Also they are in different states of excitation and hence have different energies. If some external energy in the form of light, heat, or electricity is supplied to an atom, the electrons from low energy level called ground state may jump to higher energy level called excited state. The electrons in the higher energy orbit cannot stay there for a long time. Therefore they return to the ground state spontaneously releasing the absorbed energy in the form of radiations.

LASER

The term LASER stands for Light Amplification by Stimulated Emission of Radiation. The LASER is a device which amplifies light waves similar to the transistor which amplifies electric current. The laser is a powerful source of light.

Characteristics of LASER

Laser radiation is different from normal light radiation. The characteristics of laser are given below:

1. Laser radiation is monochromatic. It contains only one particular wavelength (colour) of light. The wavelength is determined by the amount of energy released.
2. Laser radiation is coherent. In emitted radiation all the photons are having the same phase and amplitude.

3. Laser radiation is highly directional. Laser beam of light can travel very long distance, without much divergence.
4. Laser radiation is very intense. The intensity and hence the brightness of the laser radiation is high.

The radiation having single wavelength, same amplitude and same phase is called 'coherent radiation'.

Principle of LASER

Laser works on the principle of quantum theory of radiation. When an atom in the lower energy E_1 absorbs the photon energy of incident radiation, it is excited to the higher energy level of energy E_2 . This process is called absorption. The number of absorption transition take place per unit time per unit volume is directly proportional to the number of atoms in the lower energy level and the number of photons in the incident radiation.

The energy difference $E_2 - E_1$ is called excitation energy and it is equal to the energy of the photon absorbed by the atom. In higher energy level (E_2), the atom cannot remain long time, since it has a tendency to drop energy. So the atom jumps to the lower energy level (E_1). At that time, the energy difference $E_2 - E_1$ is emitted in the form of radiation as photon.

The energy of the photon released, $E_2 - E_1 = h\gamma$, where γ is the frequency of the radiation and h , the Planck's constant. (6.623×10^{-34} JS)

Spontaneous emission

Spontaneous emission is the process of photon emission takes place immediately without any inducement during the transition of atoms from higher energy levels to lower energy levels. This is a random process in which the photons are emitted at different time. So, in the emitted radiation each photon has different phase and are incoherent.

The number of spontaneous transition (N_{sp}) taking place per unit time per unit volume is directly proportional to the number of atoms in the higher energy level (N_2).

$$\text{is } N_{sp} \propto N_2 \text{ (or) } N_{sp} = AN_2$$

where A is a constant known as the probability of spontaneous transition per unit time. Also it is called Einstein's co-efficient of spontaneous emission.

Stimulated emission

Einstein found a new process called stimulated emission to increase the number of transition of atoms from higher energy levels to lower energy levels.

Stimulated emission is the process of photon emissions takes place by an inducement given by another photon incident on the atoms in higher energy levels. The energy of the photon emitted is equal to the energy of the photon incident.

Consider an atom in the higher energy level (E_2). When an external radiation of photon energy $E_2 - E_1$ is incident on the excited atom, the photon stimulates the atom to make transition from higher to lower energy level. As a result the same photon energy $E_2 - E_1$ is emitted in the form of radiation. During this process, the stimulating photon and the photon emitted by the excited atom are emitted simultaneously in the same direction. Hence they are identical in phase, direction and frequency and are coherent. This process of stimulated emission is used to produce laser beam.

The number of stimulated transition (N_{st}) taking place per unit time per unit volume is directly proportional to

- 1) the number of atoms in the higher energy level (N_2)
- 2) The number of photons in the incident radiation (Q)

$$\text{ie } N_{st} \propto N_2 Q \text{ (or) } N_{st} = BN_2 Q$$

Where B is a constant known as the probability of stimulated transition per unit time. Also it is called Einstein's co-efficient of stimulated emission.

The stimulated emission can be multiplied through a chain reaction as shown in the figure. When a single photon hits an atom in the higher energy level, two photons are emitted by stimulated emission.

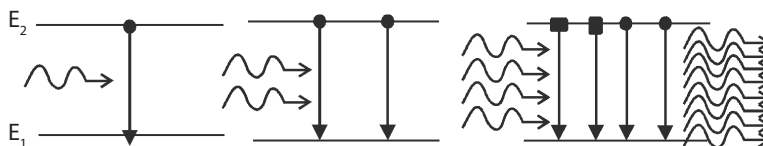

Then these two photons hit on two atoms of higher level, four photons are emitted. This process is continued as a chain reaction and the photons are getting multiplied. Finally it leads to the emission of the powerful, coherent, monochromatic and highly directional beam of laser light. This is called Light amplification by stimulated emission of radiation. This amplification takes place only if there are more number of atoms in the excited state (higher energy level) than in the ground state (lower energy level).

Population inversion

Population inversion is the establishment of the situation to make more number of atoms in the excited state required for the chain reaction of stimulated emission.

For achieving the population inversion, the number of atoms must be raised continuously to the excited state. When a sufficient energy is given to the atoms in the ground state, they are excited to the higher energy levels. This process is called pumping. If the atoms in the ground state are brought to the excited state by means of light energy, the process is called optical pumping.

Construction and working Ruby Laser

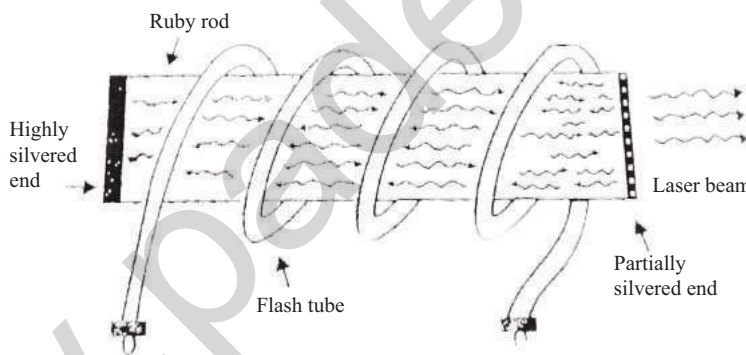

Ruby is a crystal of Aluminium oxide (Al_2O_3) with an addition of 0.05% chromium oxide (Cr_2O_3). Pink ruby is machined into a rod of about 10 cm in length and 0.5 cm in diameter. One end of the ruby rod is highly silvered and the other end is partially silvered.

Energy Level diagram for Ruby Laser

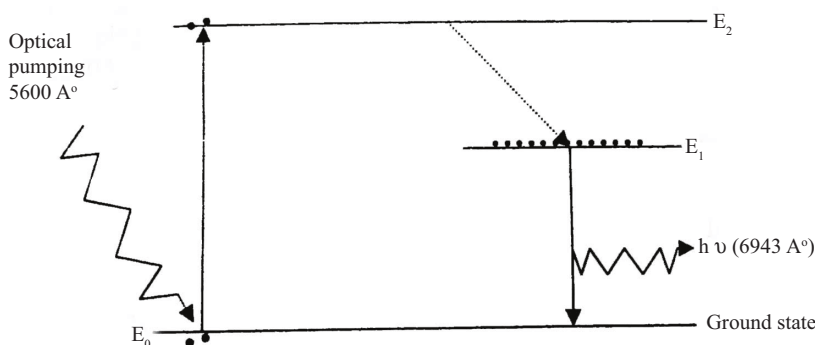

The flash light from the Xenon lamp makes the chromium ions (Cr^{3+}) in the ground state (E_0) to go to the meta stable state (E_1) by giving out energy in the form of heat. From the E_1 level the atoms jump to the E_0 level, giving out light photons of energy $(E_1 - E_0) = h \nu$.

Uses of Laser :

1. Laser is used to find the long distances by direct pulse reflection method. Using this method, the distance between the moon and earth was measured accurately.
2. It is used to produce high temperature to melt and vapourise the metals in a very short period.
3. It is used to bore holes in hard substances like tungsten and diamond.
4. It can be modulated to transmit hundred messages at a time on radio, television and telephone.
5. The big size objects like aeroplanes, missiles etc can be destroyed in a few seconds by passing a powerful laser beam on to them. For this reason, laser is called a “Death ray” instrument.
6. In surgery, a laser beam is used in spot-welding of a detached retina in the eye ball. It is also used for painless drilling and welding the surface of a tooth to prevent its decay.
7. The laser beam is not easily absorbed by water. So it can be used in under-water communication between submarines.

3.3 REMOTE SENSING

Remote sensing is the process of sensing and measuring the objects in a long distance without physical contact with them. A device used for the above purpose is called remote sensor.

Remote sensors are mounted on the aircraft or satellite platforms. The sensors receive the reflected or emitted radiations from a particular place on the earth's surface and measure the energy. These measurements are being made at a large number of points from the image of the earth's surfaces. The sensed images are interpreted in terms of geographical variations. The active power of the remote sensors depends upon the detection of energy emitted or reflected by the object.

Types of remote sensing (Active and Passive) :

The system of remote sensing is classified into two types. They are

- 1) Active remote sensing
 - 2) Passive remote sensing
- (1) Active remote sensing is the process of sensing the distant target in which the sensors direct their own generated radiations towards the target and then it detect the amount of energy reflected by the target.

Examples: Radar, Radar Altimeter, Wind scatterometer, Synthetic Aperture Radar (SAR) and Camera with flash.

- (2) Passive remote sensing is the process of sensing the distant object in which the sensors detect only the amount of energy radiated by the object.

Examples: Aerial photography, Camera without flash and Microwave radiometer.

Components of remote sensing:

The electromagnetic remote sensing process is divided into two components namely

- (1) Data acquisition and
- (2) Data analysis

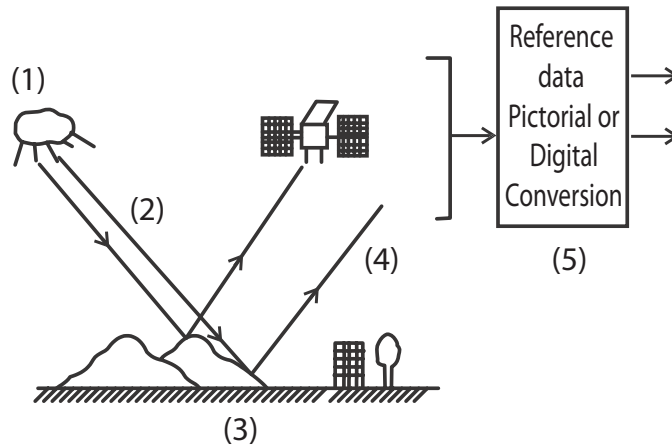

Data acquisition : The schematic diagram of data acquisition is shown in the figure. In this process, five distinct elements are involved.

They are

1. Energy Sources.
2. Propagation of energy through the atmosphere.
3. Energy interaction on earth surface.
4. Space borne sensors record the reflected energy.
5. Conversion of sensors data in the form of pictures or digital information.

The electromagnetic radiations emitted by the energy source are propagated through the atmosphere and incident on the surface of the earth. Then the radiations are reflected back towards the space borne remote sensors. The sensors generate the receiving data into picture or digital forms.

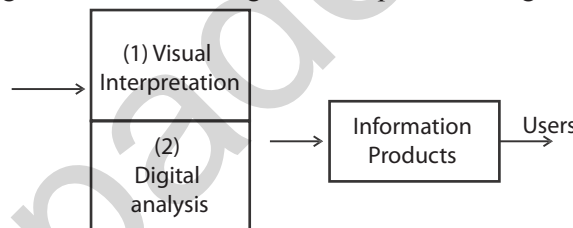

Data analysis: The schematic diagram of data analysis is shown in the figure. The data analysis is divided into two separate processes.

They are

- 1) visual interpretation technique
- 2) Digital analysis

In visual interpretation techniques, various viewing instruments are used for examining and analysing the pictorial data. In digital analysis the computers are used to analyse the digital data. All analyzing data are viewed in the information products by users. The data analysis can be carried only with the help of reference data.

The process that involves examination and analysis of pictorial data is called visual image interpretation techniques. This process involves the use of fundamental picture elements like tone, texture, pattern, shape and size in order to identify the various objects. Stereoscopic instruments are used for this purpose.

Use of computers to analyse digital data is known as digital image processing techniques. If the data is available in digital form, it can be analysed on interactive computer systems for getting statistical data. This statistical data is analysed using computers by comparing with the actual “signatures” of the objects collected through field visits. This system of classification of objects is quite accurate.

Reference data:

Whether it is pictorial data analysis or digital data analysis, reference data should be generated as supporting data. Reference data is called ground truth or field check. The reference data is used to analyse and interpret remotely sensed data and also to verify information obtained from remote sensing data. The acquisition of reference data is through actual field visits.

The collection of reference data may depend upon time-critical or time-stable measurements. The time-critical measurements are those vegetation conditions, water pollutants and climatic conditions. The time-stable are other geological measurements.

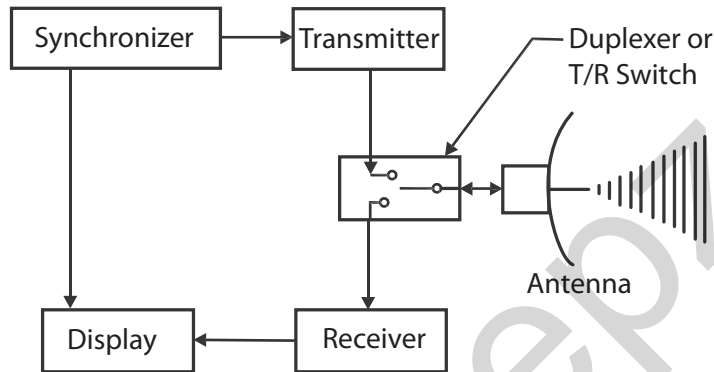
RADAR

The RADAR is an acronym derived from Radio Detection and Ranging. Radar is an electromagnetic device for detecting the presence and location of objects. The presence of the object, their range and direction are determined by the transmission and return of electromagnetic energy. The radar antenna transmits short burst pulses of energy to the target and echoes from this target carry information about the position and quality of the illuminated object. The block diagram of an elementary pulsed radar set is given above.

Radar consists of a transmitter and a receiver each connected to a directional antenna through a Duplexer or Transmitter/Receiver switch. The transmitter sends out microwave power through the antenna. The receiver collects as much energy as possible from the echoes reflected in its direction by the target. In most of the radar systems the receiving antenna is same as the transmitting antenna.

The transmitter generates a short pulse and sends it to the antenna via duplexer. As soon as a small fraction of the pulse is fed to the duplexer, it disconnects the transmitter from the antenna and connects the receiver to it. The transmitted pulse is reflected by the target and a portion of it reaches the antenna. Now the duplexer connects the receiver to the antenna so that the returning echoes can be processed. The processed pulses are fed to the necessary display devices which gives the nature and position (range) of the target. In most radars, the antenna moves in a predetermined pattern and this process is known as scanning.

QUESTION**Part –A & B**

1. What is Refraction?
2. Write the laws of refraction.
3. Define refractive index.
4. What is total internal reflection?
5. Define critical angle.
6. What is spectrometer?
7. What are the three major part of spectrometer?
8. Define angle of minimum deviation.
9. Give the formula for refractive index of the material of the prism.
10. Expand the acronym LASER.
11. Write any two of the characteristics of LASER.
12. What is the principle of LASER?
13. What is spontaneous emission?
14. What is the stimulate emission?
15. What is population inversion?
16. Write any two uses of LASER.
17. What is remote sensing?
18. What is active remote sensing?
19. What is passive remote sensing?
20. What are the important components of remote sensing?
21. What are the uses of reference data?
22. Expand the acronym RADAR.

Part-C

1. Explain the phenomenon of total internal reflection with the help of ray diagram and give the relation between critical angle and refractive index.
2. Derive the expression for refractive index of material of prism using minimum deviation.
3. Describe an experiment of determine the refractive index of the material of prism using angle of minimum deviation method.
4. Write a note on spontaneous emission, stimulated emission and population in version.
5. Describe the construction and working of RUBY LASER.
6. List the uses of Laser
7. Describe the data acquisition and data analysis of remote sensing.
8. Explain the working of RADAR with block diagram.

PROBLEMS:

1. The minimum deviation for a glass prism is 38° and the refractive index of glass is 1.509. Find the angle of the prism.

Note: use $\sin(A + B) = \sin A \cos B + \cos A \sin B$

(Ans: $A=60^\circ 8'$)

2. The refractive index of the material of a prism is 1.5. When the prism is placed in the minimum deviation position, the angle of incidence is 51° . Calculate the angle of prism and angle of minimum deviation.
(Ans: $62^\circ 24', 39^\circ 36'$)
3. Calculate the refractive index of the material of an equilateral prism. The angle of minimum deviation is 38° .
(Ans: 1.509)
4. The angle of glass prism is 59° . Calculate the angle of minimum deviation, if the refractive index of the material of the prism is 1.642.
(Ans: $48^\circ 52'$)

NOTES

www.padeepz.net

UNIT

4

ELECTRICITY

Introduction

The flow of free electrons in a conductor constitutes electric current. The current is defined as the rate of flow of charges across any cross sectional area of a conductor. The current is expressed in ampere and it is a scalar quantity. The direction of current is the direction of flow of positive charges or opposite to the direction of flow of electrons. The electric current is the flow of positive charge from a point at a higher potential to a point at a lower potential. Current flows only if there are charge carriers present in a conductor which can move freely when an electric field source is connected between the ends of the conductor. When charges are in motion, they produce magnetic effects. The current flowing through a conductor is one ampere if a charge of one coulomb flows through any section of it per second.

4.1 ELECTRICAL CIRCUITS

In an electrical circuit there must be a source of energy which provides energy to electrons so that they can move and constitute an electric current. For easy flow of current, the connecting wires must be made of conductor material. The energy source creates a potential difference across the circuit and therefore it forces electric charges to move along the conductor. When a voltage (V) is applied across a conductor, a current (I) flows in the conductor. The magnitude of current in a conductor depends on its resistance and the resistance plays an important part in the conduction.

Ohm's law

George Simon Ohm in 1826 established the relationship between potential difference and current in a conductor which is known as Ohm's law. It states that the current (I) flowing through a conductor is directly proportional to the potential difference (V) across the ends of the conductor, if its temperature remains the same.

$$\text{ie } I \propto V$$

$$\text{or } V \propto I$$

$$\text{or } V = R I$$

Where R is called the resistance of the conductor. The unit of resistance is ohm with symbol ' Ω '

There are several materials which do not obey Ohm's law. Conductor which do not obey Ohm's law are called non-ohmic conductors. This is due to increase in the resistance of the conductor when the current increases. Transistors, crystal rectifiers etc., do not obey Ohm's law.

Laws of Resistances

When more than one resistor is to be connected in an electric circuit they can be connected either in series or in parallel. The equivalent resistance offered in the circuit by a group of resistor depends on the way of their combination.

Resistances in Series

The resistances are connected in series combination will increase the effective resistance in the circuit. When a number of conductors are connected end to end so that the same current flows through all of them, then they are said to be in the series combination.

Consider AB, BC and CD are three conductors of resistances R_1 , R_2 and R_3 respectively connected in series as shown in the figure. Let I be the current flowing through them and V_1 , V_2 and V_3 be the potential differences across R_1 , R_2 and R_3 respectively.

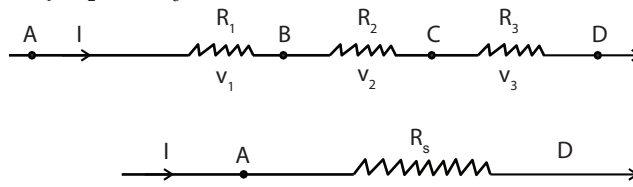

Let AD be the equivalent resistance (R_s) carrying the same current I and having a potential difference V across the ends A and D such that

$$V = V_1 + V_2 + V_3$$

Applying Ohm's law we get,

$$IR_s = IR_1 + IR_2 + IR_3$$

i.e. $R_s = R_1 + R_2 + R_3$

Thus, when a number of conductors are connected in series, the equivalent resistance is equal to the sum of the individual resistances.

Resistances in Parallel

The resistances are connected in parallel combination to decrease the effective resistance in the circuit. When a number of resistors are connected to common terminals so that the potential difference across each conductor is the same, then they are said to be in parallel combination.

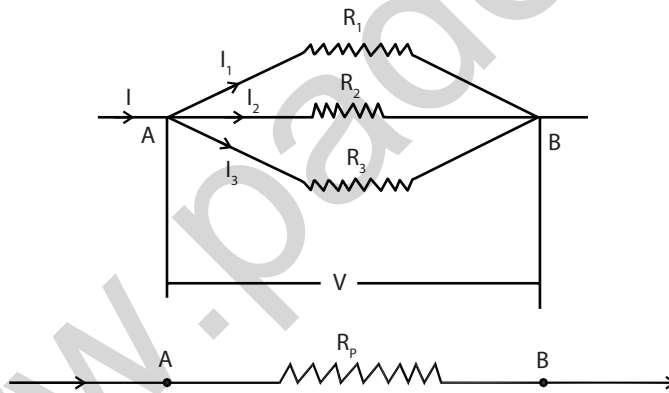

Consider R_1 , R_2 and R_3 are the resistances of the conductors connected between the point A and B and V is the common potential difference across AB. Let I_1 , I_2 and I_3 be the current through the individual branches.

Let AB be the equivalent resistance (R_p) having a potential difference V and carrying a current I such that,

$$I = I_1 + I_2 + I_3$$

Applying Ohm's law we get,

$$\frac{V}{R_p} = \frac{V}{R_1} + \frac{V}{R_2} + \frac{V}{R_3}$$

i.e., $\frac{1}{R_p} = \frac{1}{R_1} + \frac{1}{R_2} + \frac{1}{R_3}$

Thus, when a number of conductors are connected in parallel, the reciprocal of the equivalent resistance is equal to the sum of the reciprocals of the individual resistances.

Resistivity

The resistance of a conductor is directly proportional to the length of the conductor and inversely proportional to the area of cross section of the conductor.

$$R \propto l$$

$$R \propto \frac{1}{A}$$

$$\text{i.e., } R \propto \frac{l}{A}$$

$$R = (\rho) \frac{l}{A}$$

$$\therefore \rho = \frac{RA}{l}$$

ρ is called the resistivity or specific resistance of the material of the conductor.

The resistivity or specific resistance of a material is defined as the resistance offered by a conductor of unit length having unit area of cross section. The unit of resistivity is ohm metre ($\Omega \text{ m}$).

Conductivity

The reciprocal of resistivity of the material of a conductor is called as its conductivity. It is denoted by σ

Based on the above expression of conductivity, the unit of conductivity is mho/m.

$$\sigma = \frac{1}{\rho}$$

$$\sigma = \frac{l}{RA}$$

Superconductivity

At very low temperature the resistance of the most of the conductors becomes very low essentially zero. And so, the current passes freely through them, this phenomenon is called Superconductivity. The temperature below which a conductor becomes superconductor are called transition temperature. The material which goes to super conducting state when called below transition temperature are called superconductors.

Meissner Effect

When a specimen is placed in a magnetic field and then cooled below its transition temperature for superconductivity the magnetic flux originally present inside the specimen is ejected from the specimen. This process of ejection of magnetic flux from the super conducting material as the material goes transition from conducting state into super conducting state is known as Meissner effect.

Kirchoff's current and voltage laws

In electrical circuits which consist of simple arrangement of resistors in series or in parallel with a given source of emf, all calculations can be carried out using Ohm's law. But in more complicated circuits where there are junctions between more conductors and where more than one source of emf are active, then Kirchoff's laws can be useful for calculation purposes. There are two laws called Kirchoff's current law and Kirchoff's voltage law.

First law – Kirchoff's Current law or junction law

“In any network of conductors, the algebraic sum of the currents meeting at any junction is zero”.

The convention applied in the junction rule is that the current flowing towards a junction is taken as positive and the current flowing away from the junction is taken as negative.

Let i_1, i_2, i_3, i_4 and i_5 be the current passing through the five conductors and meeting at the junction 'O'. Then according to Kirchoff's first law,

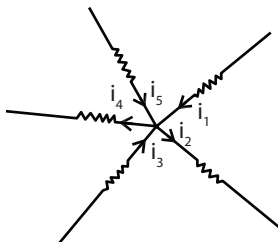

$$i_1 - i_2 + i_3 - i_4 + i_5 = 0$$

$$\text{or } i_1 + i_3 + i_5 = i_2 + i_4$$

That is, the sum of the currents flowing towards the junction is equal to the sum of the currents flowing away from the junction.

Second law – Kirchoff's Voltage law or mesh law

“In any closed electrical network, the algebraic sum of the products of current and resistance in each branch of a network is equal to the algebraic sum of the emfs in that network.”

The current direction may be assumed either clockwise or anti- clockwise. The convention applied is, if the current flows in the same direction in which we are considering the network or mesh, it is taken as positive and the current in opposite direction is taken as negative. The emf which sends the current in the same direction in which the mesh is considered, it is taken to be positive and emf which sends the current in the opposite direction is taken to be negative.

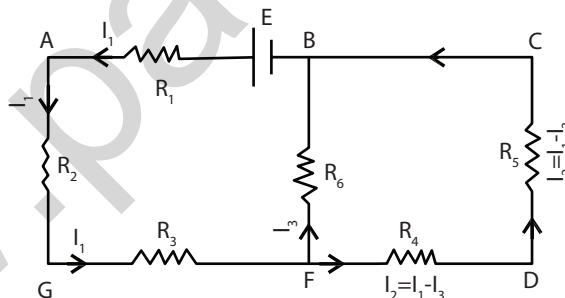

For the network BAGFB we have

$$I_1 R_1 + I R_2 + I_1 R_3 + I_3 R_6 = E$$

For the network FBCDF we have

$$I_3 R_6 - (I_1 - I_3) R_5 - (I_1 - I_3) R_4 = 0$$

Condition for balancing the Wheat stone's Bridge

Wheatstone bridge is a very accurate and precise method of determining an unknown resistance and it is an important application of Kirchoff's laws. Since it is a null method, the measurement of unknown resistance is not affected by the internal resistance of the battery used.

Wheatstone bridge or network consists of four resistances P,Q,R and S connected in the form of a quadrilateral ABCD. A galvanometer of resistance G is connected between the opposite end points B and D. A cell of emf E and a key are connected between the opposite end points A and C.

When the circuit is closed different currents flow through various branches of the network as shown in the diagram. According to Kirchoff's current law I_g is the current passing through the galvanometer. Considering the network ABDA, applying Kirchoff's second law,

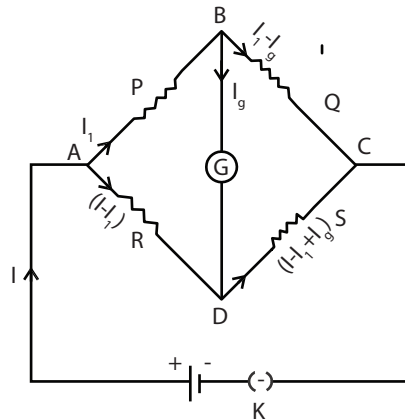

$$I_1 P + I_g G - (I - I_1) R = 0$$

$$\text{or } I_1 P + I_g G = (I - I_1) R \quad (1)$$

Considering the network BCDB, applying Kirchoff's second law

$$(I_1 - I_g) Q - (I - I_1 + I_g) S - I_g G = 0$$

$$\text{or } (I_1 - I_g) Q = (I - I_1 + I_g) S + I_g G \quad (2)$$

The four resistances P, Q, R and S are adjusted so that there is no deflection in the galvanometer. i.e. $I_g = 0$. Now the bridge is said to be balanced.

Now, equation (1) becomes

$$I_1 P = (I - I_1) R \quad (3)$$

and equation (2) becomes

$$I_1 Q = (I - I_1) S \quad (4)$$

dividing (3) by (4) we get

$$\frac{I_1 P}{I_1 Q} = \frac{(I - I_1) R}{(I - I_1) S}$$

$$\frac{P}{Q} = \frac{R}{S}$$

This is the balancing condition of Wheatstone's bridge network.

Solved Examples

1. Calculate the resistance of a wire of length 1.5 m and diameter 0.8 mm.

The specific resistance of the material of the wire is 45×10^{-8} ohm m

Given

$$l = 1.5 \text{ m}$$

$$d = 0.8 \text{ mm} \quad r = 0.4 \text{ mm}$$

$$= 0.4 \times 10^{-3} \text{ m}$$

$$\rho = 45 \times 10^{-8} \text{ ohm m}$$

We know specific resistance $\rho = \frac{RA}{l}$

$$\text{Resistance } R = \frac{\rho l}{A}$$

$$\text{ie } R = \frac{\rho l}{\pi r^2}$$

$$\frac{45 \times 10^{-8} \times 1.5}{3.14 \times (0.4 \times 10^{-3})^2} = 1.343 \text{ ohm.}$$

2. Calculate the resistivity of a material of a wire whose resistance is 1.5 ohm with a diameter of 0.32 cm and length 80 cm.

Given

$$R = 1.5 \text{ ohm}$$

$$\text{Diameter} = 0.32 \text{ cm} \quad r = 0.16 \text{ cm}$$

$$r = 0.16 \times 10^{-2} \text{ m}$$

$$l = 80 \text{ cm}$$

$$= 80 \times 10^{-2} \text{ m.}$$

We know specific resistance $\rho = \frac{RA}{l}$

$$= \frac{R\pi r^2}{l}$$

$$= \frac{1.5 \times 3.14 \times (0.16 \times 10^{-2})^2}{80 \times 10^{-2}}$$

$$= 15.07 \times 10^{-6} \text{ ohm m}$$

4.2 EFFECTS OF CURRENT

If a positive charge is moved from a point at a higher potential to a point at a lower potential, energy is liberated. When current flows in a conductor, the electrons collide with the ions because of the acceleration of electrons and energy is transferred to the ions. Therefore, there is increase in the energy of the ions and the temperature of the conductor rises and thereby it is heated. This is called heating effect of electric current. This heating effect was studied by Joule.

Joule's law of heating

The quantity of heat developed (H) in a conductor is

(i) directly proportional to the square of the current passing through the conductor ie $H \propto I^2$

(ii) directly proportional to the resistance of the conductor ie $H \propto R$

(iii) directly proportional to the time of flow of current ie $H \propto t$

$$\text{ie } H \propto I^2 R t$$

$$H = I^2 R t$$

where I is in ampere ,R is in ohm and t is in second

$$\text{But } R = E/I$$

$$\therefore H = I^2 \frac{E}{I} t$$

$$H = EI t \text{ joule}$$

The heating effect of electric current is applied in the working principle of electric fuse wire, electric heater, electric welding and electric furnace.

Experimental determination of specific heat capacity of a liquid using Joule's calorimeter

The specific heat capacity of a liquid can be determined experimentally using Joule's calorimeter.

The Joule's calorimeter is a polished copper or aluminum vessel containing the given liquid.

It is covered by a non-conducting lid and a suitable resistance coil is immersed in the liquid and its ends are connected to connecting terminals provided in the lid. There are holes in the lid for a stirrer and inserting a thermometer. The calorimeter is placed inside a wooden box and it is filled with cotton or wool to minimize the radiation losses.

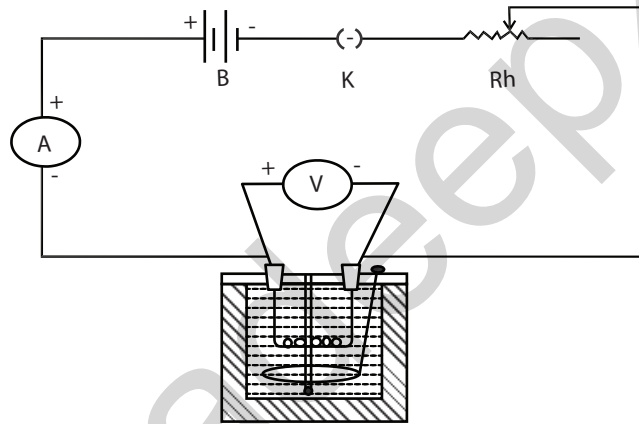

The mass of the clean, empty calorimeter with stirrer is determined and it is taken as m_1 kg. Now the calorimeter is filled with the given liquid and its mass is determined with stirrer and it is taken as m_2 kg. The heating coil should be immersed well in the liquid. The calorimeter is now placed inside the wooden box.

A battery, an ammeter, a key and a rheostat are connected in series with the coil and a voltmeter is connected in parallel across the coil. The current is adjusted for about one ampere. The circuit is kept open. The ammeter reading and the voltmeter reading are noted as I and E . Now, a thermometer is inserted through the hole in the lid. The initial temperature of the liquid is noted (θ_1 °C). When the circuit is closed, simultaneously a stop clock is started. The liquid is stirred well and when the temperature rises about 5°C, the circuit is kept open and the stop clock is stopped and the final temperature θ_2 °C is noted. The time is noted as t second.

The heat produced by the heating coil = $E I t$ joule.

Heat is absorbed by both the calorimeter and the liquid.

Heat absorbed by the calorimeter = $m_1 s(\theta_2 - \theta_1)$ joule

where 's' is the specific heat capacity of the material of the calorimeter.

[Heat absorbed = mass \times specific heat capacity \times rise in temperature]

Heat absorbed by the liquid = $(m_2 - m_1) S (\theta_2 - \theta_1)$ joule.

Heat produced = Heat absorbed

i.e. $EIt = m_1 s (\theta_2 - \theta_1) + (m_2 - m_1) S (\theta_2 - \theta_1)$ J kg⁻¹ K⁻¹

The specific heat capacity of the liquid S is given by

$$\frac{EIt}{(m_2 - m_1) (\theta_2 - \theta_1)} - \frac{m_1 s}{(m_2 - m_1)} \text{ J kg}^{-1} \text{ K}^{-1}$$

CHEMICAL EFFECT OF CURRENT

The phenomenon of conduction of electricity through liquid was first studied by Faraday in 1833. Pure liquid does not conduct electricity, but the conductivity of a liquid increases if the solution contains an acid. The molecules of a salt in solution are supposed to break up into two parts, positive and negative ions and this process is called dissociation.

When an electric field is applied between two electrodes dipping in the solution, the positively charged ions move towards the negative electrode (cathode) and they are called as Cations. The negatively charged ions move towards the positive electrode (anode) and they are called as Anions.

The process of chemical decomposition of an electrolyte by the passage of electric current through it is called electrolysis.

The liquid containing the compound is called an electrolyte and the vessel containing the electrolyte is called a voltameter.

Faraday's laws of electrolysis

The two laws of electrolysis are stated as follows.

First law

The mass of an element liberated at cathode from an electrolyte by passing of electric current is directly proportional to

(I) The strength of the current (I)

(ii) The time for which the current is passed through the electrolyte (t)

ie $m \propto I$

and $m \propto t$

ie $m \propto I t$

or $m = ZIt$

Here, the constant Z is known as the electrochemical equivalent (e.c.e) of the element.

Second law

If the same current passes through different electrolytes for the same time then the masses of the elements liberated from electrolytes are directly proportional to their respective chemical equivalent weights.

Let m_1 , m_2 and m_3 be the masses of the elements liberated by the passage of the same current through the electrolytes for the same time whose chemical equivalent weights are E_1 , E_2 and E_3 , then according to second law,

$m_1 \propto E_1$; $m_2 \propto E_2$ and $m_3 \propto E_3$

$$\text{or } \frac{m_1}{E_1} = \frac{m_2}{E_2} = \frac{m_3}{E_3}$$

Electro-chemical equivalent (e.c.e) of an element

According to Faraday's First law of electrolysis

$$m \propto It$$

or $m = ZIt$

Where Z is a constant called electrochemical equivalent of the given element

When $I = 1$ ampere and $t = 1$ second, then $Z = m$

Therefore the electro-chemical equivalent of an element is defined as the mass of the element liberated from an electrolyte when one ampere current is passed through it for one second. Since $Z = m/It$ the unit of e.c.e is kilogram per ampere second or kg C^{-1} (ampere second = coulomb).

Experimental determination of e.c.e of copper

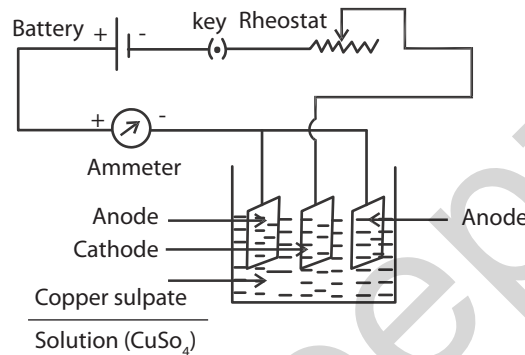

Copper voltameter is used for the determination of electro-chemical equivalent of copper. It consists of a glass vessel containing copper sulphate solution and this is the electrolyte. There are three electrodes of copper plates dipped in the solution. The two outer plates are connected to the positive terminal of the battery through the ammeter and they act as anodes. The central copper plate is connected to the negative terminal of the battery and this plate is the cathode plate.

A battery, a plug key, a rheostat and an ammeter are connected in series with the copper voltameter. The circuit is closed and the rheostat is adjusted to send suitable current for a while and then the circuit is kept open.

The cathode plate is taken out, polished well with sand paper, washed and dried. The mass of the cathode is determined carefully correct to a milligram, using a digital balance. The cathode is then kept in its position and when the circuit is closed, simultaneously a stop clock is started. The current value is maintained the same by adjusting the rheostat, if necessary, and it is allowed to pass for thirty minutes. After the time the current is stopped and the cathode plate is taken out, rinsed with water, dried and then weighed correct to a milligram.

The difference between the final and the initial mass gives the mass of copper deposited on the cathode plate and this is taken as m . Let I be the current that is passed through the electrolyte and t the time for which current is passed. Then electro-chemical equivalent

$$Z = m / It \text{ Kg C}^{-1}$$

Thus, the e.c.e of copper is determined using the above equation.

Solved Examples:

1. Calculate the electro-chemical equivalent of copper when a current of one ampere passing through a coppervoltmeter for one hour liberates 1.2 g of copper.

Given,

$$\begin{aligned} m &= 1.2 \text{ g} \\ &= 1.2 \times 10^{-3} \text{ kg} \end{aligned}$$

$$\begin{aligned} t &= 1 \text{ hour} \\ &= 3600 \text{ s} \end{aligned}$$

$$I = 1 \text{ ampere}$$

$$\begin{aligned} \text{ECE of copper } Z &= \frac{m}{It} \\ &= \frac{1.2 \times 10^{-3}}{1 \times 3600} \\ &= 3.33 \times 10^{-7} \text{ kg C}^{-1} \end{aligned}$$

2. Calculate the mass of copper deposited when a current of one ampere flows for 30 minutes in a copper voltameter. e.c.e of copper = $3.33 \times 10^{-7} \text{ kg C}^{-1}$.

Given,

$$\begin{aligned} I &= 1 \text{ ampere} \\ t &= 30 \text{ minutes} \\ &= 30 \times 60 \\ &= 1800 \text{ s} \\ Z &= 3.33 \times 10^{-7} \text{ kg C}^{-1} \end{aligned}$$

$$\begin{aligned} \text{We know } Z &= \frac{m}{It} \\ m &= Z I t \\ m &= 3.33 \times 10^{-7} \times 1 \times 1800 \\ m &= 5.994 \times 10^{-4} \text{ kg.} \end{aligned}$$

3. Calculate the current required to deposit 3.3 g of silver in 45 minutes. e.c.e of silver = $1.118 \times 10^{-6} \text{ kg C}^{-1}$

Given,

$$\begin{aligned} m &= 3.3 \text{ g} \\ &= 3.3 \times 10^{-3} \text{ kg} \\ t &= 45 \text{ minutes} \\ &= 45 \times 60 \\ &= 2700 \text{ s} \\ Z &= 1.118 \times 10^{-6} \text{ kg C}^{-1} \end{aligned}$$

We know,

$$\begin{aligned} Z &= \frac{m}{It} \\ I &= \frac{m}{Zt} \\ &= \frac{3.3 \times 10^{-3}}{1.118 \times 10^{-6} \times 2700} \end{aligned}$$

$$I = 1.093 \text{ ampere}$$

4. 2×10^{-3} kg of gold is to be deposited electrolytically by passing a current of 1.2 ampere. What will be the time taken? e.c.e of gold is 68×10^{-6} kg C⁻¹

Given,

$$m = 2 \times 10^{-3} \text{ kg}$$

$$I = 1.2 \text{ ampere}$$

$$Z = 0.68 \times 10^{-6} \text{ kg C}^{-1}$$

We know,

$$Z = \frac{m}{It}$$

$$\therefore t = \frac{m}{ZI}$$

$$t = \frac{2 \times 10^{-3}}{0.68 \times 10^{-6} \times 1.2}$$

$$t = 2451 \text{ s.}$$

CAPACITORS

Apart from resistors and insulators, a capacitor is also the other basic passive component commonly used in electrical circuits. Capacitor is a device which has the ability to store charges in the form of electrical energy, which neither a resistor nor an insulator can do.

An ideal capacitor may retain the charges stored in it for a long time, after power supply is removed from the circuit. That is, it can store charges for ever. This stored charge can discharge through a conductor (or) wire. This discharge can cause shock or damage to the connected equipment, during the misuse of capacitors in a circuit.

Construction of a capacitor :

Two similar metallic conductors separated by an insulator (or) dielectric medium forms a capacitor. Conductor – insulator – conductor sequence is the basic idea behind a capacitor.

The basic difference between insulator and dielectric medium is :

The materials which do not have free electrons in them are unable to conduct electricity and they are termed as insulators.

Some material like ceramic behaves as a dielectric medium. Charges are induced in the opposite faces of it, because of the external applied electric field. Such material is called dielectric.

All dielectric materials are insulators, but not all insulators make good dielectric materials.

The dielectric medium could be air, mica, ceramic, paper, polyester, Teflon, etc.

In the figure shown below two metallic conductors of equal area “A” separated by a dielectric medium, forms a two terminal device, named as Capacitor.

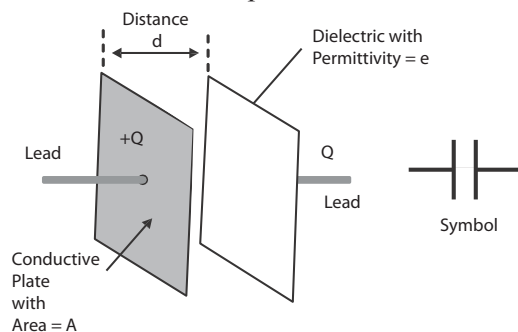

The plates are kept perfectly parallel to each other. So it is called as parallel plate capacitor. The conducting plates of a capacitor can be either square or circular or rectangular or cylindrical or spherical in shape. Shape selection depends on its application and voltage rating.

Capacitance:

An ideal capacitor is characterized by a single constant value named as capacitance. The capacitance of a capacitor is defined as amount of charge required to create a unit potential difference between its plates or capacitance can also be defined as the ratio of charge to potential difference.

$$C = \text{Charge} / \text{p.d} = \frac{Q}{V} \text{ farad}$$

If $Q = 1 \text{ coulomb}$ and $V = 1 \text{ volt}$

Then $C = 1 \text{ farad (F)}$

Capacitance of a capacitor depends upon the area of the plate, distance of separation between the plates “d” or thickness of the dielectric medium used.

The unit of capacitance is 'farad' with symbol 'F' named after British Physicist Michael Faraday.

Definition of ‘farad’:-

One farad is defined as the capacitance of a capacitor which requires a charge of one coulomb to establish a p.d of one volt between the plates.

How many electrons are present in one coulomb of charge?

Let there be “n” electrons in one coulomb. But charge $q = ne$, where ‘e’ is the charge of one electron.

Therefore $n = \frac{q}{e} = \frac{1}{1.6 \times 10^{-19}} = 6.25 \times 10^{18} \text{ electrons}$

So to establish one volt p.d. between the two plates, large number of electrons have to move from one plate to another plate. So one farad is too large for practical purposes.

In most of the cases we have smaller unit like

one milli farad = $1 \text{ mF} = 1 \times 10^{-3} \text{ F} = 0.001 \text{ F}$

one micro farad = $1 \text{ }\mu\text{F} = 1 \times 10^{-6} \text{ F} = 0.000\ 001 \text{ F}$

one nano farad = $1 \text{ nF} = 1 \times 10^{-9} \text{ F} = 0.000\ 000\ 001 \text{ F}$

The symbol for capacitors is not unique. In the modern electronic world, the symbol for capacitors are given below.

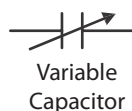

PRECAUTION:

Capacitors in series:-

Let us consider three capacitors of capacitances C_1 , C_2 and C_3 respectively connected in series as shown in the figure.

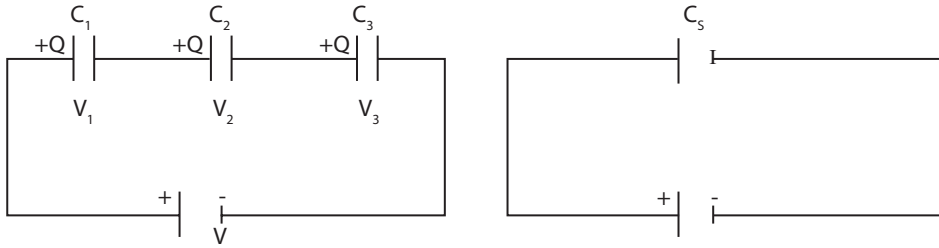

Due to the inducement of charges on the plates by the applied p.d.,

- 1) Charge on each capacitor is same irrespective of its capacitance.
- 2) p.d. across each capacitor is different
- 3) Sum of the voltage across the capacitors is equal to the applied battery Voltage “V”.

$$\text{So, } V = V_1 + V_2 + V_3 \quad \longrightarrow (1)$$

We know $C = \frac{Q}{V}$ (or) $V = \frac{Q}{C}$
So the p.d. between the first capacitor is

$$C_1 = \frac{Q}{V_1} \text{ (or) } V_1 = \frac{Q}{C_1}$$

Similarly for second and third capacitors

$$V_2 = \frac{Q}{C_2} \text{ and } V_3 = \frac{Q}{C_3}$$

substituting all in equation (1)

$$\frac{Q}{C} = \frac{Q}{C_1} + \frac{Q}{C_2} + \frac{Q}{C_3}$$

If C_s is the effective capacitance of the series connection, then

$$\frac{Q}{C_s} = Q \left(\frac{1}{C_1} + \frac{1}{C_2} + \frac{1}{C_3} \right)$$

Canceling Q on both sides

$$\frac{1}{C_s} = \left(\frac{1}{C_1} + \frac{1}{C_2} + \frac{1}{C_3} \right)$$

When capacitors are connected in series the reciprocal of the effective capacitance is equal to the sum of the reciprocals of the individual capacitances.

Hence connecting capacitors in series is equivalent to increasing the thickness of the electric medium. When we increase the thickness, distance increases. So capacitance decreases.

Capacitors connected in series block DC and allow AC.

Capacitors Connected in Parallel :-

Let us consider three capacitors of capacitances C_1 , C_2 and C_3 respectively connected in parallel as shown in the diagram.

The charge Q supplied by the battery is divided among the three capacitors as Q_1 , Q_2 and Q_3 . Therefore,

- 1) Charges across each capacitor are different.
- 2) p.d. across all capacitors is same
- 3) Sum of the charges stored in the capacitors is Q

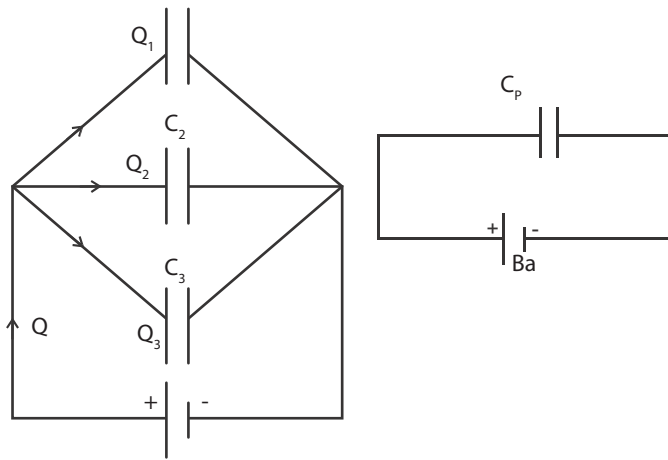

$$\therefore Q = Q_1 + Q_2 + Q_3$$

$$\text{We know } C = \frac{Q}{V} \text{ (or) } Q = CV$$

The charge stored on the first capacitor is

$$Q_1 = C_1 V.$$

Similarly for other two capacitors

$$Q_2 = C_2 V \text{ and } Q_3 = C_3 V$$

Substituting this in equation (1) above

$$CV = C_1 V + C_2 V + C_3 V$$

If C_p is the effective capacitance of the parallel connection, then $C_p V = V (C_1 + C_2 + C_3)$

Cancelling the “V” on both sides

$$C_p = C_1 + C_2 + C_3$$

When capacitors are connected in parallel, the effective capacitance is equal to the sum of the individual capacitances

Connecting capacitors in parallel is equivalent to adding their plate areas. Hence, combined capacitance equals to sum of the individual capacitances.

Solved Problems:

- Three capacitors each of capacitance 9 pF are connected in series. Calculate the effective capacitance of the capacitors and potential difference across each capacitor, when they are powered by 120V DC supply.

Given values:-

$$C_1 = 9 \text{ pF}, C_2 = 9 \text{ pF} \text{ and } C_3 = 9 \text{ pF}$$

In series connection with p.d. of 120 v.

$$C_1 = C_2 = C_3 = 9 \text{ pF}$$

For series connection,

$$\frac{1}{C_s} = \frac{1}{C} + \frac{1}{C} + \frac{1}{C} = 3 \left(\frac{1}{C} \right)$$

$$\frac{1}{C_s} = 3 \times \frac{1}{9 \times 10^{-12}} = \frac{1}{3 \times 10^{-12}}$$

Therefore $C_s = 3 \times 10^{-12} \text{ F} = 3 \text{ pF}$

In series connection, sum of the p.d across the capacitor is equal to supply voltage 120 V

$$V = V_1 + V_2 + V_3$$

$$120 = \frac{q}{C_1} + \frac{q}{C_2} + \frac{q}{C_3} = \frac{q}{C} + \frac{q}{C} + \frac{q}{C}$$

$$120 = 3 \frac{q}{C} = \frac{3q}{9 \times 10^{-12}} \quad 120 = \frac{q}{3 \times 10^{-12}}$$

$$q = 3 \times 120 \times 10^{-12} = 360 \text{ pC}$$

Therefore, potential difference across each capacitor

$$V = \frac{q}{\text{Capcitanace}} = \frac{360 \times 10^{-12}}{9 \times 10^{-12}} = 40 \text{ V}$$

2. Calculate the effective capacitance of three capacitors of capacitance 1 mF, 2 mF and 4 mF respectively, when they are connected in series and parallel configuration in a circuit.

Given values:-

$$C_1 = 1 \text{ mF}, C_2 = 2 \text{ mF} \text{ and } C_3 = 4 \text{ m F}$$

(a) When they are connected in series

$$\frac{1}{C_s} = \left(\frac{1}{C_1} + \frac{1}{C_2} + \frac{1}{C_3} \right)$$

$$= \left(\frac{1}{1} + \frac{1}{2} + \frac{1}{4} \right) \frac{1}{10^{-3}}$$

$$= \frac{1 + 0.5 + 0.25}{10^{-3}} = \frac{1.75}{10^{-3}}$$

$$C_s = \frac{1 \times 10^{-3}}{1.75} = \frac{1}{1.75} \times 10^{-3}$$

$$C_s = 0.571 \times 10^{-3} = 0.571 \text{ m F}$$

(b) When they are connected in parallel

$$C_p = C_1 + C_2 + C_3 = (1 + 2 + 4) \times 10^{-3} \text{ F}$$

$$C_p = 7 \times 10^{-3} \text{ F} \quad C_p = 7 \text{ m F}$$

4.3 MEASURING INSTRUMENTS

When charges are in motion they produce magnetic effect. An electric current produces magnetic field. Therefore moving charged particles in magnetic field experience force.

Expression for the force acting on a current carrying straight conductor placed in a uniform magnetic field

Let us consider a small element PQ of a straight conductor of length l , which carries a current I . This is placed in a uniform magnetic field of magnetic induction B . The current passing through the conductor is due to the flow of electric charges. Let θ be the angle between the direction of current flow and the magnetic induction B . Let there be 'n' number of free charges each of charge 'q' moving with a velocity v through the conductor.

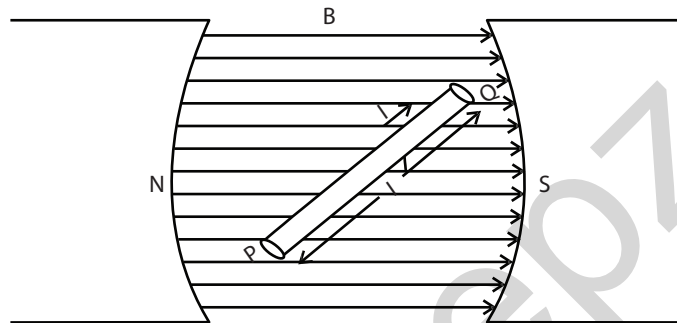

We know force on each charge $F = B q v \sin \theta$

Since there are n numbers of charges moving in the conductor of length l ,

The total force experienced by the conductor is given by

$$F = B n q v \sin \theta$$

In a conductor current is the rate of flow of charges

$$\text{i.e. Current} = \frac{\text{Charge}}{\text{time}}$$

$$I = \frac{nq}{t}$$

Here t is the time taken by a charge to travel a distance l of the conductor.

From the above relation $nq = I t$

The total force experienced by the conductor is given by

$$F = B I t v \sin \theta$$

The velocity of charges is the distance travelled by them in time t

$$\text{i.e., } v = \frac{l}{t}$$

$$F = B I t \frac{l}{t} \sin \theta$$

$$F = B I l \sin \theta$$

This expression gives the force on a straight conductor placed in a uniform magnetic field.

Suppose if the straight conductor is placed at right angles to the magnetic field then $\theta = 90^\circ$

The force acting on the conductor is given by

$$F = B I l \sin 90^\circ$$

$$\text{ie } F = B I l (\sin 90^\circ = 1)$$

The direction of the force is given by Fleming's left hand rule.

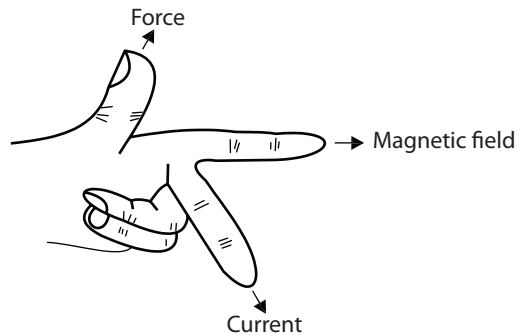
Fleming's Left Hand rule

The direction of motion of current carrying conductor placed in a uniform magnetic field is given by Fleming's Left Hand rule. According to this rule, when the forefinger, middle finger and thumb of the left hand are stretched mutually perpendicular to each other and if the forefinger represents the direction of magnetic field, the middle finger represents the direction of current in the conductor, then the thumb gives the direction of motion of the conductor.

Expression for the torque experienced by a rectangular current carrying coil placed in a uniform magnetic field

Consider a rectangular coil ABCD placed in a uniform magnetic field of induction B . Let l be the length of the coil and 'b' its breadth. The magnetic field acts parallel to the plane of the coil and perpendicular to the sides AB and CD. Let I be the current passing through the coil.

Now the side AB of length l experiences a force $B I l$, since the angle between this side and the magnetic field is 90° . The direction of this force is given by Fleming's left hand rule. The side CD also experiences an equal force of $B I l$ but in the opposite direction, since the current on this side flows in opposite direction.

But the sides BC and AD are parallel to the direction of the magnetic field and hence there is no force acting on these two sides.

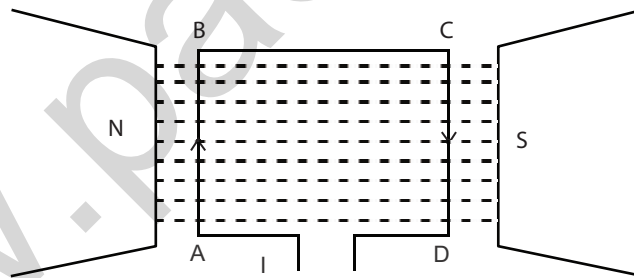

Therefore, the two equal unlike and parallel forces acting on the sides AB and CD constitute a couple. Torque is the moment of the couple in the coil.

Moment of the couple = One of the forces \times the perpendicular distance between the forces.

This perpendicular distance is the distance between the two sides AB and CD, measured along the direction of the field. It should be noted that this distance is not a constant and varies from position to position of the coil. The breadth BC of the coil (b) gives the maximum distance.

The maximum torque on the coil = $B I l \times b = B I A$

(where $l \times b = A$, The area of cross section of the rectangular coil)

If there is 'n' number of turns in the coil then the maximum torque is given by $n B I A$.

Working of a Moving coil galvanometer

The principle of the moving coil galvanometer is that a coil of conductor carrying current placed in a magnetic field experiences a torque.

The moving coil galvanometer consists of a rectangular coil of wire of many turns wound on a nonmagnetic metallic frame and is suspended between two strong permanent magnetic poles N and S. The coil is suspended by means of a fine phosphor bronze wire from a movable torsion head. The coil is held tight by a hair spring S. A small light mirror M is attached to the suspension fibre and the angle of deflection of the coil can be measured with a lamp and scale arrangement. A small soft iron cylinder is fixed at the centre of the coil for producing a radial magnetic field.

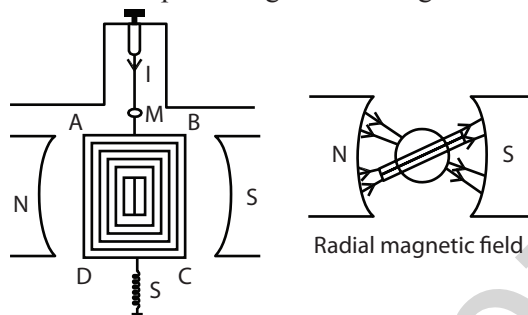

Now, when a current of I ampere passes through the vertical limb AD of the rectangular coil $ABCD$, it experiences a force perpendicular to it and directed outwards according to Fleming's left hand rule. Similarly the limb BC experiences an equal and opposite force to that of AD and directed inwards. It should be noted that in all the position of the coil, the forces on the sides AD and BC will always perpendicular to the magnetic field, since the plane of the coil remains parallel to the magnetic field. No force acts on the sides AB and CD , since they are parallel to the magnetic field. The coil will come to rest in a deflected position.

According to Fleming's left hand rule the forces experienced by the sides AD and BC are $B I l$ and $B I l$ where, l is the length of the sides and B is the magnetic induction. These forces constitute a couple and the controlling couple is provided by the torsion in the phosphor bronze suspension fibre.

For one turn of the coil, the deflection couple produced = $B I l \times b$ where b is the breadth of the coil.

$$\begin{aligned} \text{For 'n' turns of the coil, the deflection couple produced} &= n B I l \times b \\ &= n B I A \end{aligned}$$

where $l \times b = A$, the area of coil.

If C is the couple per unit twist of the suspension wire then for a twist θ , the restoring couple = $C \theta$ (The deflection θ can be measured from the lamp and scale arrangement)

For equilibrium position,

$$\begin{aligned} \text{Deflecting Couple} &= \text{Restoring couple;} \\ \text{i.e; } n B I A &= c \theta \end{aligned}$$

$$I = \frac{C}{n B A} \cdot \theta$$

The current required (I / θ) to produce unit deflection is called the figure of merit of the Galvano meter, $K = \frac{C}{n B A}$

Since C, n, B and A are all constants $I = K \theta$

$$\text{i.e, } I \propto \theta$$

The current is directly proportional to the deflection produced. For a small value of I , if the deflection θ is large, then the galvanometer is said to be sensitive.

Merits of moving coil galvanometer

- (i) The external magnetic fields do not alter the deflection of the coil since there is a strong magnetic field between the pole pieces, and the galvanometer can be placed in any position.
- (ii) Since the deflection of the coil is directly proportional to the current, a uniformly divided scale can be used to measure the current.

Conversion of a galvanometer in to an ammeter

A galvanometer is a very sensitive device used to detect the strength of flow of current and large current cannot be passed through it, because large current flow can easily damage the coil. Therefore a low resistance called shunt is connected in parallel to the galvanometer to avoid the damage of the coil and only a fraction of the current will pass through the galvanometer and most of the current passes through the shunt.

A galvanometer can be converted into an ammeter by connecting a suitable low resistance called shunt in parallel to it.

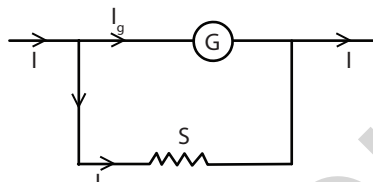

Consider a galvanometer of resistance G ohm. If the galvanometer is to be converted into an ammeter, a low resistance called shunt S should be connected in parallel with the galvanometer.

Let I_g be the maximum current that can be passed through the galvanometer and this current will give the full scale deflection in the galvanometer. Therefore out of the total current of I ampere in the circuit, the current passing through the shunt is

$$I_s = (I - I_g)$$

Since the galvanometer and the shunt are parallel.

$$I_g G = (I - I_g) S$$

$$\therefore S = \frac{I_g G}{I - I_g}$$

The current I_g is a fraction of I and the scale is marked in ampere. In an electrical circuit, ammeter is always to be connected in series.

Conversion of a galvanometer into a voltmeter

The voltmeter should have high resistance, then only it will not draw any appreciable current from the circuit. It is used to measure the potential difference across two points of an electrical circuit.

A galvanometer can be converted into a voltmeter by connecting a high resistance in series with the galvanometer.

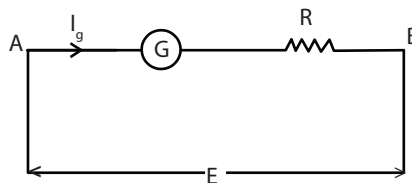

Consider a galvanometer of resistance G ohm. If it is to be converted into a voltmeter, a high resistance R should be connected in series with it to read E volt.

Let I_g be the current required to produce full scale deflection in the galvanometer. A and B are two terminals of the voltmeter. Since the high resistance R is connected in series with the galvanometer, the current I_g passes through both the galvanometer and the high resistance.

$$E = I_g (G + R)$$

$$\text{i.e. } \frac{E}{I_g} = G + R$$

$$\text{and } R = \frac{E}{I_g} - G$$

The scale is marked in volt. In an electrical circuit, a voltmeter is always connected in parallel between the two terminals across which the p.d. is to be measured.

Solved Examples

1. A galvanometer has a resistance of 5 ohm and full scale deflection is produced by 15 mA. Calculate what resistance must be used to enable it to read (i) 1.5 ampere (ii) 1.5 volt.

Given,

$$\text{Full scale deflection } I_g = 15 \text{ mA} = 15 \times 10^{-3}$$

$$\text{A Galvanometer resistance } G = 5 \text{ ohm}$$

$$I = 1.5 \text{ A}$$

$$\text{We know, } S = \frac{I_g G}{I - I_g}$$

$$S = \frac{1.5 \times 10^{-3} \times 5}{1.5 - (15 \times 10^{-3})} = 0.05 \text{ ohm}$$

A shunt of 0.05 ohm is to be connected in parallel with the galvanometer so as to measure upto 1.5 ampere.

$$\text{Potential difference } E = 1.5 \text{ volt}$$

$$\text{We know, } R = \frac{E}{I_g} - G$$

$$= \frac{1.5}{15 \times 10^{-3}} - 5$$

$$= 95 \text{ ohm}$$

A resistance of 95 ohm is to be connected in series with the galvanometer so as to measure up to 1.5 V.

2. A galvanometer has a resistance of 200 ohm and when a current of 1mA passes through it, produces a deflection of 1 division. How this can be converted into a voltmeter to read 10 volt per division ?

Given,

$$G = 200 \text{ ohm}$$

$$E = 10 \text{ volt}$$

$$I_g = 1 \text{ mA} = 1 \times 10^{-3} \text{ A}$$

$$\text{We know, } R = \frac{E}{I_g} - G$$

$$R = \frac{10}{10^{-3}} - 200$$

$$R = 10000 - 200 = 9800 \text{ ohm}$$

A high resistance of 9800 ohm is to be connected in series with the galvanometer so as to measure up to 10 volt / division

3. The resistance of a galvanometer is 100 ohm and it can withstand a maximum current of 100 mA. How this can be converted into an ammeter to read 10A.

Given,

$$G = 100 \text{ ohm}$$

$$I_g = 100 \text{ mA} = 100 \times 10^{-3} \text{ A}$$

$$i = 10 \text{ A}$$

$$\text{We know, } S = \frac{I_g G}{I - I_g}$$

$$S = \frac{100 \times 10^{-3} \times 100}{10 - 100 \times 10^{-3}}$$

$$S = \frac{10}{10 - 0.1}$$

$$S = 1.01 \text{ ohm}$$

A shunt of 1.01 ohm should be connected in parallel with the galvanometer to measure up to 10 A.

QUESTIONS

PART A & B

1. Write the law of resistances when the resistances are connected in series
2. Write the law of resistances when the resistances are connected in parallel
3. Define the term Resistivity
4. Define the term Conductivity
5. What is super conductivity?
6. What is Meissnor effect?
7. Write Kirchoff's current law
8. Write Kirchoff's voltage law
9. What is a Wheatstone's Bridge?
10. What is meant by heating effect of electric current?
11. Write Joule's law of heating
12. Define electrolysis
13. Write Faraday's first law of electrolysis
14. Write Faraday's second law of electrolysis
15. What is a Voltmeter?
16. Define Electro-chemical equivalent (e.c.e) of an element

17. Define capacitance of a capacitor.
18. Define farad.
19. Write three dielectric medium used in a capacitor.
20. Write the energy stored in capacitor, with details.
21. Write the expressions for effective capacitance when two capacitors are connected in Series and inparallel.
22. Find the effective capacitance when two equal capacitors are connected in series
23. Write Fleming's left hand rule
24. Write the principle of a moving coil galvanometer
25. What is meant by the figure of merit of a galvanometer?
26. What are the merits of a moving coil galvanometer?

Part-C

1. Derive the condition for balancing the Wheatstone's network.
2. Describe an experiment to determine the specific heat capacity of a liquid using Joule's calorimeter.
3. Describe an experiment to determine the electrochemical equivalent of copper using copper voltameter.
4. Derive the expression for effective capacitance when three capacitors are connected in series.
5. Derive the expression for effective capacitance when three capacitors are connected in parallel.
6. Derive an expression for the force acting on a current carrying straight conductor placed in a uniform magnetic field
7. Derive an expression for the torque experienced by a rectangular current carrying coil placed inside a uniform magnetic field.
8. Describe the construction and working of a moving coil galvanometer with a diagram
9. Describe how a galvanometer can be converted into i) an ammeter and ii) a voltmeter.

Exercise problems

1. Calculate the resistance of the wire of length 1.5 m and diameter 0.5mm if the resistivity of the material of the wire is 49×10^{-8} ohm metre. [Ans 3.745 ohm]
2. Calculate the resistivity of the material of a wire of length 25.6 m and diameter 0.84 mm whose resistance is 0.72 ohm [Ans 1.557×10^{-8} ohm metre]
3. Calculate the resistance of a wire of 1.5m long and area of cross - section 0.4mm^2 whose resistivity is 46×10^{-8} ohm metre [Ans 4.312 ohm]
4. Calculate the electro chemical equivalent of a metal when a current of one ampere liberates in one hour 1.2 g of metal from its electrolyte [Ans 3.33×10^{-7} kg C⁻¹]
5. What will be the time taken for 2.2×10^{-3} kg of gold is to be deposited electrolytically by passing a current of one ampere ? Given, e.c.e of gold = 0.68×10^{-6} kg C⁻¹ [Ans 3235 s]
6. Calculate the amount of current that should be passed through a copper voltameter to deposit 3.12g of copper in one hour (e.c.e of copper = 3.33×10^{-7} kg C⁻¹) [Ans 2.6A]
7. A galvanometer of resistance 30 ohm shows maximum deflection for a current of 2 mA. How this can be converted into a voltmeter to read 10V?
[Ans 4970 ohm connected in series with the galvanometer.]
8. An ammeter of resistance 0.60 ohm can measure current up to 1A. What must be the shunt resistance to enable the ammeter to measure current upto 5A ? [Ans 0.15 ohm]

9. Show that when two equal capacitors are connected in parallel, the system has four times the capacitance of that obtained, when they are connected in series ($C_p = 4C_s$)
10. Find the resultant capacitance of three capacitors of capacitance 20mF, 30mF and 50mF, when they are connected in series and in parallel.
11. The capacitors of capacitance 3mF and 5mF are connected in series. Calculate the effective capacitance of the capacitors and potential difference across each Capacitor, when they are powered by 60 V DC supply.

Brain Teaser

1. In the electrification of a house how the various lamps are connected? Explain Why?
2. Why does a silver voltameter give accurate results than a copper voltameter?
3. Two capacitors of capacitance 3mF and 6mF are connected in series and charged by connecting a battery of 10V. Next replace the battery from the circuit, connect a wire between the terminals (show circuiting process). What is the final charge stored on the capacitors?

UNIT

5

ELECTRONICS

5.1 SEMICONDUCTORS

Introduction

The branch of science and engineering dealing with current conduction through vacuum tube or semiconductor is known as electronics.

Initially, vacuum tubes were used in the process of electrical signal generation, amplification and transmission. With the advent of semiconductor devices like diode, transistor and other solid state electronic components, the vacuum tubes were replaced completely from all fields of applications. All modern gadgets like television, computer, CD player, automatic washing machine, etc., use microprocessors having integrated chips which consist a large number of logic gates, diodes, transistors, resistors, etc.,

Materials are classified as conductors, insulators and semi conductors according to their electric conductivity. This classification is purely based on the available number of free electrons within the materials, apart from the bonded orbital electrons.

So the word conductivity is used to describe a material's ability to transport electricity. The metals like copper and gold are good conductors. Glass and plastics, on the other hand, are very bad conductors. Semi conducting materials like germanium and silicon has conductivity somewhere between good conductors and insulators.

In semiconductors, charges movement can be manipulated according to our need to make electronic devices. So silicon and germanium are used as a base material for making electronic components like diode, transistors, etc.

New emerging organic semi conductors with similar properties resembling conventional semi conductors are available now. In general, now a day's semi conductors are classified as inorganic and organic semi conductors. One can fabricate diode, transistors and other devices using organic semiconductors which are bio degradable electronic devices.

Devices fabricated using inorganic semi conductors like silicon, Germanium, Gallium Arsenide, Silicon carbide etc., are not bio degradable which poses threat to our green environment. So the new organic semi conductors will give us biodegradable materials, to lead green electronic world.

Energy Band in Solids:

During solid formation, the outer most energy levels of the atoms overlap with each other to form a band of energy. An energy band consists of closely spaced energy levels, which are considered to be continuous.

The outermost electrons of an atom are called valence electrons and the band of energy occupied by the valence electrons is known as valence band (V.B.) This valence band may be partially filled or completely filled but it cannot be empty.

The next higher permitted band of energy is called the conduction band (C.B.). It is located above the valence band. The electrical conductivity of solids depends on the number of electrons present in the conduction band of their atoms. The conduction band may be empty or partially filled and can never be completely filled. When the electrons reach the conduction band from the valence band, they can freely move, so they are called as free electrons or conduction electrons. These free electrons are responsible for flow of electric current through the solid. The gap between the valence band and the conduction band is called the forbidden energy gap (F.G.).

Materials are classified as good conductors, insulators and semiconductors based on their ability to conduct electricity.

Energy band diagram for Conductors, insulators and semiconductors:-

Our interest is focused on conducting property of a material. In general, physical and chemical properties of an element are decided by the valence orbital electrons. For example, if valence orbit is filled, with element is inert like He, Ne, etc. On the other hand the materials with unfilled valence orbit exhibit electrical and magnetic properties like metals. So, only valence band is considered for further studies. The other low level bands are not contributing any significant changes in the conducting properties.

The energy band occupied by the valence electrons is called valence band (V.B.)

Next, the conducting band (C.B) lies above the valence band. Conduction band is due to the free electrons from the atoms of the crystal or solid. These free electrons possess kinetic energy and acts as a carrier within the crystal.

The energy band diagrams for good conductors, insulators and semi conductor are shown in the figure below.

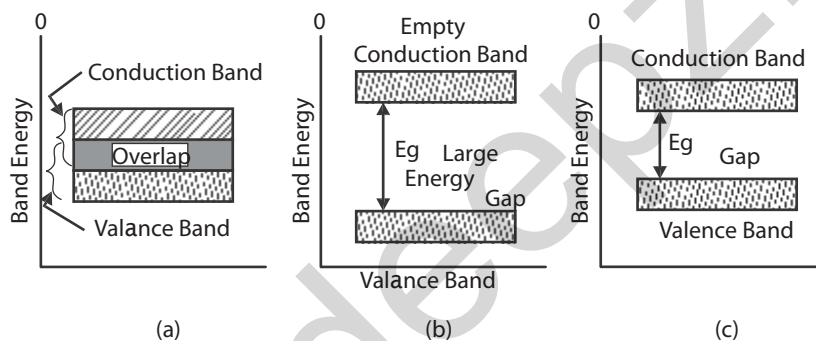

The above energy band diagram has a gap between V.B. and C.B, named as forbidden energy gap. So based on the energy gap between the valence band and conduction band, the materials are classified as good conductor, bad conductor and semi conductor.

(a) For good conductors, $E_g = 0$. Here valence band and conduction band is overlapping each other.

Zinc is a good example for conductor which has overlap of valence band and conduction band. In Zinc, valence band is completely filled and the conduction band is empty, but they overlap each other. Because of overlap, it is considered as single band. Hence conduction band is assumed as partially filled. Therefore, on applying a small electric field, the metals conduct electricity.

(b) For Insulator, E_g value is large.

In insulators like diamond, the forbidden energy gap is quite large. The forbidden energy gap value is 6 eV, so minimum of 6 eV energy is required for electron to move from valence band to conduction band. Normally conduction band is empty and valence band is full for insulators. Since there is no electron for conduction, these type of materials behave as insulators.

(c) For Semiconducting materials, the E_g value is very small.

The energy band structure of the semi conductor is similar to the insulator, but the forbidden gap is very narrow. The forbidden energy gap is 1.1 eV for Silicon. The semi conductor acts as an insulator at 0 K and at room temperature the thermal energy absorbed from the surrounding is enough for the electron to jump from the valence band to the conduction band. So a semiconductor starts conducting at room temperature.

Fermi level:-

At 0 K, the electrons start filling the energy levels in valence band, from bottom to top level. Few electrons fill the bottom level and other electrons above this level. So filling of energy starts from bottom of the band to top of the band.

The highest energy level, which an electron can occupy in the valence band at 0 K, is named as Fermi level.

Fermi level is also defined as the energy level corresponding to the average energy of electrons and holes present in the crystal.

Intrinsic Semi conductors:-

In general, semi conductors are classified as intrinsic and extrinsic semi conductors. Semiconductors in pure form are called intrinsic semi conductor. Example:- A crystal formed by silicon atoms alone. The silicon atoms are arranging themselves by sharing an electron between the neighbouring atoms. Such bond is covalent bond.

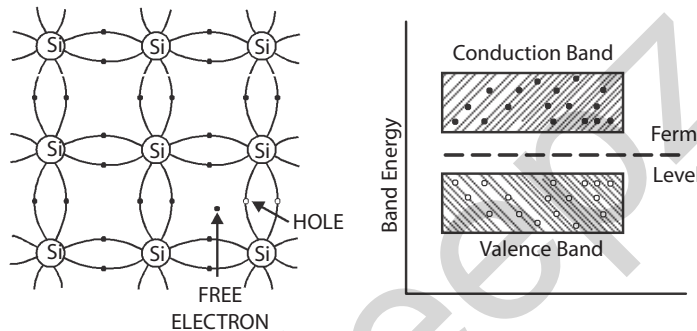

In intrinsic semiconductor like silicon forbidden energy gap value is 1.1 eV. This energy is available for semiconductors placed at room temperature. Due to that thermal energy some covalent bond within the crystal breaks (or) some electrons are pumped from valence band to conduction band. In the bond from which electron is freed, a vacancy is created there. This absence of electron is named as hole. Electron and hole pair is created. Thus at room temperature, a pure semi conductor will have both electrons and holes wandering in random directions. This electron and holes are called intrinsic carriers and such a semiconductor is called intrinsic semiconductor.

As the crystal is electrically neutral, the number of electron is equal to number of holes, in intrinsic semiconductor.

∴ Fermi level lies at the middle of the forbidden gap.

Concept of holes:

The vacant place created in the valence band due to the jumping of electron from the valence band to conduction band is called 'hole', which is having positive charge.

Doping:-

Pure semiconductor at room temperature possesses free electrons and holes but their number is so small that conductivity offered by the pure semiconductors cannot be used for any practical purpose like device making.

By the addition of certain selected impurities to the pure semi conductor in a very small ratio (1:10⁶), the conductivity of a silicon or germanium crystal can be remarkably improved.

The process of adding impurity to a pure semi conductor crystal to improve its conductivity is named as doping.

Extrinsic Semiconductor :-

The impurity added semiconductors are named as extrinsic semiconductors. The extrinsic semiconductors are classified as P-type and N-type semiconductors, based on the type of impurity atoms added to the semi conductors.

N-Type (Extrinsic) Semiconductor:-

Pentavalent element like antimony (Sb) or arsenic (As) is added to pure silicon crystals. These impurity atoms replace some of the silicon atoms, here and there in the crystal. The added arsenic (As) atom shares its four electrons with the neighbor atoms and releases its fifth electron to the crystal for conduction. So these pentavalent elements are called donor impurities, as they donate electrons. Without creating holes.

In silicon, an electron needs 1.1 eV to move from the valence band to the conduction band. This energy becomes available to the semiconductor even at room temperature. So at room temperature few covalent bonds within the material are broken by the thermal energy from the surrounding and some electrons from the valence band are pumped to the conduction band. This process leaves some absence of electrons in the valence band. Electron and hole pairs are created. At the same time, the number of electrons in the conduction band is increasing further by the addition of pentavalent impurities without any addition of holes which already exist within the crystal. So the numbers of electrons are donor electrons plus thermal electrons at room temperature. This thermal excitation produces very less pair of electrons and holes, whereas the added impurity donates more electrons. The majority charge carriers electrons are of the order of 10^{24} , whereas the minority charge carriers holes are of the order of 10^8 at 300 K.

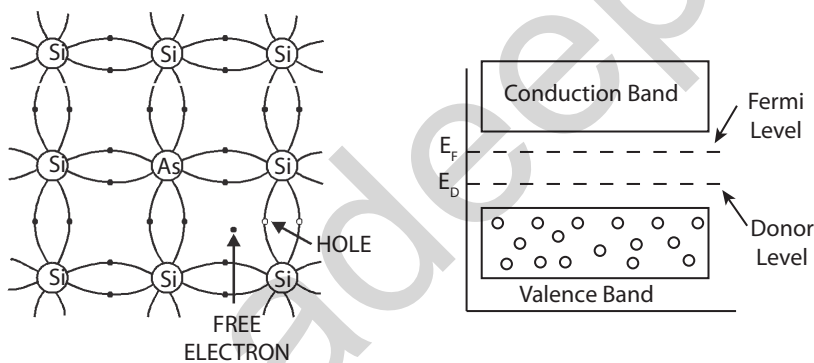

Hence, the majority charge carriers are electrons in this material. The electron carries negative charge, so it is named as N-type semiconductor and conduction is due to a large number of electrons.

As the number of electrons in the conduction band is more than the number of holes in the valence band, in an N-type semiconductor, the Fermi level lies nearer to the conduction band.

P-type Semiconductor:-

When a trivalent element like Indium, Aluminium, or Boron is doped with pure silicon, the added impurity atoms replace some of the silicon atoms, here and there in the crystal and establish covalent bonds with the neighboring atoms. Indium has three electrons but that Indium is covered by four silicon atoms as shown in the figure below. So, one of the covalent bonds is not completed by sharing of electrons between them. There is an absence of an electron which creates a hole.

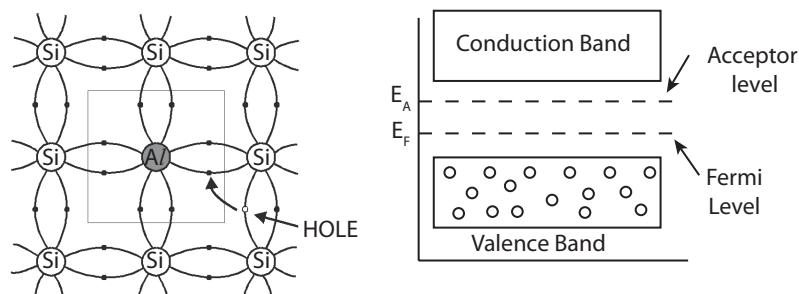

Indium needs one more electron to complete its covalent band. So indium is an acceptor of electrons. Now, this extrinsic semiconductor gains thermal energy from the surrounding at room temperature. So some electron absorbs this thermal energy and jumps to the conduction band. This creates electrons and holes pair due to thermal excitation. So the total number of holes in the valance band is due to donor's atom plus thermally generated holes.

The holes are majority and electrons are minority. Hence conduction is due to majority charge carriers which are holes. Here the holes are behaving like positive charge carriers. So this material is named as P-type.

As the number of holes in the valance band is more than the number of electrons in the conduction band, the Fermi level lies nearer to the valance band, in P type semiconductor.

5.2. DIODES AND TRANSISTORS

Introduction :-

To understand electronic devices and circuits, brief idea about semiconductor diodes is must. The semi conductor diode is a fundamental two terminal electronic device, similar to a resistor. The volt–ampere (V-I) relationship of a resistor is linear. However, the V-I characteristic of a diode is not only non linear but also depends on the operating condition. That is resistor allow the charge carriers at any condition and behaves like passive element. A diode allows current to pass through it in one direction and acts as a switch in electronic circuits.

P-N junction diode:-

At the room temperature, a piece of P-type material has majority of holes and N-type material has a majority of electrons. When a part of intrinsic semiconductor piece is doped with pentavalent impurities and the remaining part is doped with trivalent impurities, a P-N junction diode is formed.

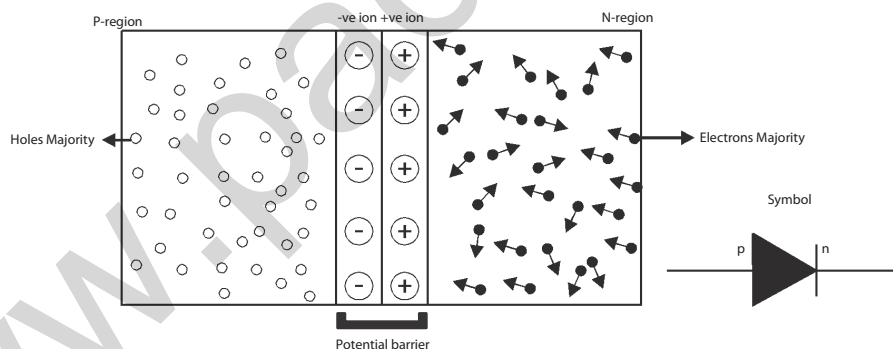

Potential barrier and depletion region:

In the PN junction diode as shown in the above figure, the P region has circles with a negative sign indicating immobile ions and the mobile holes are represented by small circle.

In the N region, the circles with a positive sign inside represents immobile ions and the mobile free electrons are represented by small dots.

During the junction formation, the free electrons and holes on both sides of the junction migrate across the junction by the process of diffusion. The electrons passing through the junction from N region into the P region recombines with holes in the P region very close to the junction.

Similarly the holes crossing the junction from the P region into the N region recombine with the electrons in the N region very close to the junction. This recombination of free or mobile charges produces a narrow region on either sides of the junction of width about 10^{-4} cm to 10^{-6} cm. This region is called the depletion region, where there are no mobile charges available.

In the depletion region, the atoms on the left side of the junction become negative ions (-) and the atoms on the right side of the junction become positive ions (+). Thus an internal potential difference (p.d.) is produced across the junction. This p.d. is called the internal potential barrier. This prevents the further flow of charge carrier from P-region to N-region. The potential barrier for germanium is 0.3 V and that for silicon is

0.7 V. The potential barrier of a PN junction diode can be decreased or increased by applying external voltage.

This barrier acts like a battery. However the value of potential barrier depends upon the number of diffused impurity atoms within the silicon crystal (or) depends upon the dopant concentration.

The arrow mark or arrow-head represents holes current flow direction (Conventional Current flow direction), when they form a circuit with an external source.

Forward and Reverse biasing of P-N junction diode:

Biasing:

Applying a suitable d.c. voltage to a diode is known as biasing. It can be done in two ways.

Forward Biasing:

When the positive terminal of the battery is connected to the P-type semiconductor and the negative terminal to the N-type semiconductor of the P-N junction diode, the junction is said to be forward biased.

When the applied voltage is increased from zero, the holes and the electrons move towards the junction. Therefore the depletion layer is decreased and disappeared i.e., the potential barrier is disappeared.

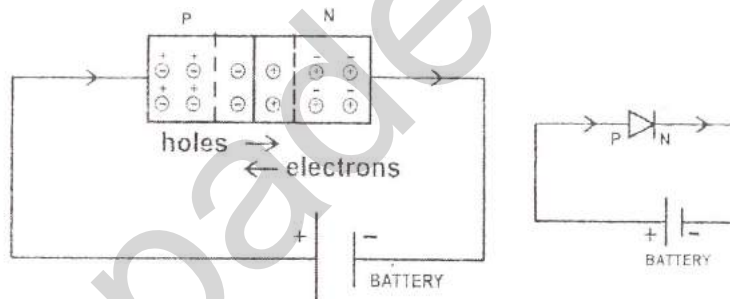

While the holes and the electrons move across the junction, they combine together and are neutralized. Electrons from the battery move into the N-type semiconductor. Further they move across the junction and come out of the P-type semiconductor. Hence there is a flow of current. The current is due to flow of electrons. Thus the P-N junction diode conducts electricity. As the battery voltage increases, the current also increases. The current is of the order of milli ampere (mA).

Reverse biasing:

When the negative terminal of the battery is connected to the P-type semiconductor and the positive terminal to the N-type semiconductor of the P-N junction diode, the P-N junction diode is said to be reverse biased. The negative potential of the battery attracts the holes. Similarly, the positive potential of the battery attracts the electrons. Therefore the holes and electrons move away from the junction. Hence the width of the depletion layer increases and there is no current flow through the junction during reverse bias. However, as the reverse bias voltage increases, the minority charge carriers move across the junction. Therefore there is a very feeble current, which is of the order of microampere (μA).

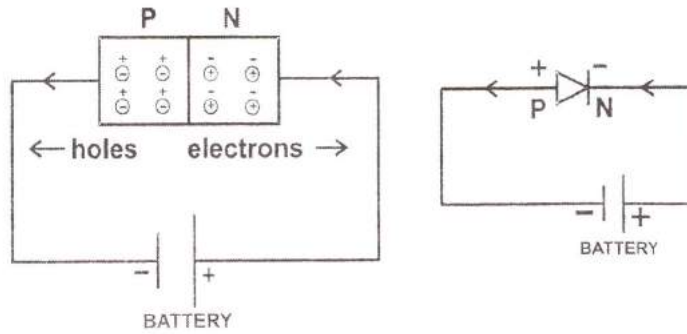

Diode acts as a switch. In forward biased state diode is in “ON” position and in the reverse biased condition the same diode is in “OFF” position. So diode is an electronic device which allows the conventional current flow in one direction alone.

Diodes can be used in a number of ways. For example, a device that uses batteries often contains a diode that protects the device if you insert the batteries backward. This diode simply blocks any current from leaving the battery if it is reversed. It protects the sensitive electronic devices.

P-N junction diode – Rectification:

A P-N junction diode conducts electricity when it is forward biased and it does not conduct electricity when it is reverse biased. Hence it is used to rectify alternating voltage (A.C).

The process in which an AC voltage is converted into a unidirectional (D.C) voltage is known as rectification and the circuit used for the conversion is called a rectifier.

An electronic device which converts a.c. signal into d.c. signal is named as rectifier.

Principle:-

It is based on the principle that a junction diode offers low resistance path for input signal, when forward biased and high resistance under reverse biased condition. When a.c. input is applied to a junction diode, it gets forward biased during the positive half cycle and reverse biased for negative half cycle.

The Full Wave Bridge Rectifier

This type of rectifier uses four diodes connected in a closed loop "bridge" configuration to produce the desired output. The main advantage of this bridge circuit is that it does not require a special centre tapped transformer, normally used in the two diodes based full wave rectifier, thereby reducing its size and cost. The secondary winding is connected to one pair of opposite ends of the diode bridge network and the load resistance to the other two opposite corners of the bridge as shown below.

Full wave rectifier

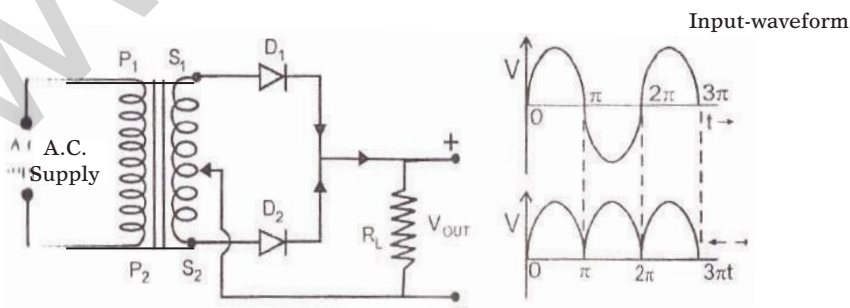

A simple circuit using PN junction diodes for full wave rectification is shown. A transformer is used to step down the input voltage P_1, P_2 are the primary coil of the transformer (through which the supply A/C. voltage(230 V) is applied. S_1, S_2 are the secondary coil of the transformer). O is the center tap of the secondary coil. Two PN junction diodes D_1, D_2 are used. R_L is the load resistance connected between the centre tap O of the secondary coil and the junction of the N-region of the two PN junction diodes.

During the first half positive cycle of the AC input, S_1 is positive and S_2 is negative with respect to O. Current flows through D_1 because it is forward biased and no current flows through D_2 as it is reverse biased. During the second half cycle of the AC input, S_1 is negative and S_2 is positive with respect to O. Current flows through D_2 because it is forward biased and no current flows through D_1 as it is reverse biased.

Thus during the positive and negative half cycles, current through R_L flows in the same direction. Thus unidirectional current or potential difference is obtained as output across R_L . Since both the positive and negative half cycles are converted into a unidirectional potential difference, is known as full wave rectifier.

The fluctuations in the output voltage across the load resistance can be smoothed, using suitable filter circuits.

Transistor :

A junction diode cannot be used for amplifying a signal. For amplification another type of semiconductor device called 'transistor' is used. Transistor is a three sectioned semiconductor. Transistor is a solid state device. Two P-N junction diodes placed back to back form a three layer transistor.

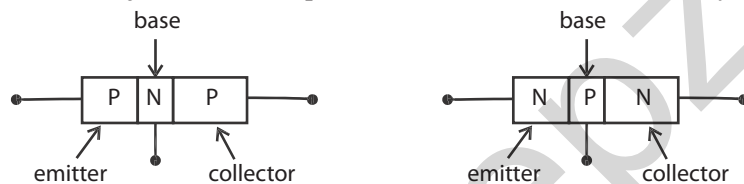

The three sections of the transistors are called emitter [E], base [B] and collector [C]. In a transistor the emitter is heavily doped, since emitter has to supply majority carriers. The base is lightly doped. Two types of transistors are available, namely N-P-N and P-N-P transistor.

Symbol for transistors:-

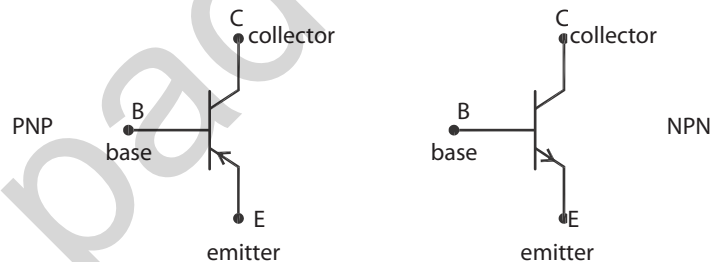

In the symbolic representation for a transistor, the arrow mark is placed on the emitter in the direction of conventional current flow, i.e., from P to N direction.

Three different Configurations :-

In an electronic circuit a transistor can be connected in three different ways. They are,

- (I) Common base (CB)
- (ii) Common emitter (CE)
- (iii) Common Collector (CC)

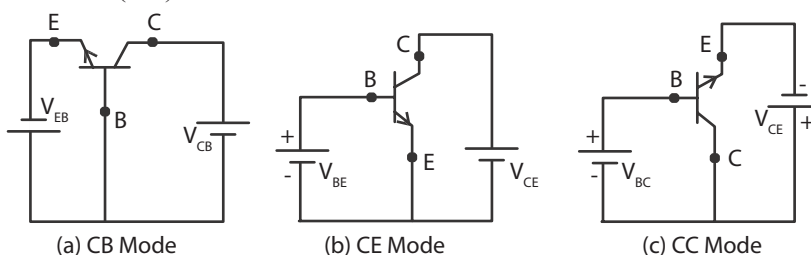

The term common is used to denote the lead that is common to the input and output circuits. The three different modes are shown above for NPN transistor .

For proper working of a transistor, the input junction should be forward biased and the output junction should be reverse biased.

Why do we need amplification ?

When we cannot hear a stereo system, we have to increase the volume, when picture in our television is too dark, we should increase the brightness control. In both of these cases, we are taking a relatively weak signal and making its stronger (i.e., increasing of its power). The process of increasing the power of an a.c. signal is called amplification.

The circuit used to perform this function is called amplifier. An amplifier may also be defined as a device, which amplifies the input weak signal. The input signal may be obtained from a phonograph, tape head or a transducer such as thermocouple, pressure gauge etc.

Transistor Amplifier- Common Emitter configuration (NPN):

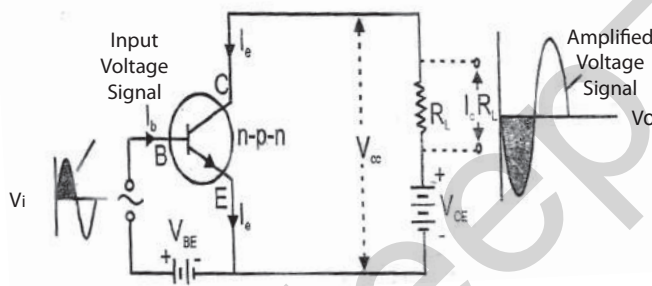

Amplifier is an electronic device which is used to magnify the amplitude of weak signal. A common emitter configuration of NPN transistor amplifier circuit is shown in the figure. The potential V_{BE} with input AC signal V_i is applied between base and emitter and the potential V_{CE} is applied between collector and emitter through the load resistance R_L . The output amplified signal voltage V_o is obtained between collector and emitter.

The amplification of the transistor is explained by using its transfer characteristic curve shown in the figure. It gives the variation of collector current I_c with increase of base current I_b at constant V_{CE} .

$$\text{Current gain, } \beta = dI_c / dI_b$$

In common emitter configuration, the collector current is β times larger than the input base current. So that the variation in I_c is much more than that in I_b . If the input signal raises, it increases the I_b from OP to OA and also there is a corresponding increase in I_c from PQ to AA'. If I_b decreases from OA to OP, I_c also decreases from AA' to PQ. Similarly it happens in reverse direction also. As it continues an amplified sine wave form of I_c flows in the circuit. Both the frequencies of input and output are the same. If I_c increases the potential drop across R_L also increases.

From circuit,
$$V_o = V_{CE} - I_c R_L$$

As per equation, the increase of potential across R_L opposes the V_{CE} . So that the input signal and the output voltage are out of phase that is differ the phase by 180° .

A.C. power gain :

It is the ratio of the change in output power to the change in input power.

$$\begin{aligned} \text{A.C. power gain} &= \frac{\text{Change in output power}}{\text{Change in input power}} \\ &= \left(\frac{dI_C}{dI_b} \right)^2 \frac{R_{out}}{R_{in}} \end{aligned}$$

Advantages of common emitter configuration :

On comparing the three different configurations of an amplifier, with help of their characteristics like input impedance, output impedance, current gain, voltage gain, power gain and phase reversal the following are the major advantages of common emitter configuration when compared with other configurations.

- (a) High input impedance
- (b) Low output resistance
- (c) Moderate current gain
- (d) High voltage gain
- (e) High Power gain
- (f) Phase reversal

In common emitter amplifier, the output signal is 180° out of phase with input signal.

5.3 DIGITAL ELECTRONICS**Introduction**

With the invention of the transistor in 1948 by W.H.Brattain and I.Bardeen, the electronic circuits became considerably reduced in size. It was due to the fact that a transistor is cheaper, easily available, smaller compare to vacuum tube, less power consuming. It is widely used in many electronic circuits.

With the development of printed circuit board (PCB) which further reduced the size of electronic equipments in the early 1960's a new field of "microelectronics" was born primarily to meet the requirements of the military, which wanted to reduce the size of its electronic equipment. The drive for extremely small size of microelectronic circuits ends up with an invention of integrated circuits (ICs). Integrated circuits can contain anything from one to millions of logic gates, flip-flops, multiplexers, and other circuits in a few square millimetre. The small size of these circuits allows high speed, low power dissipation and reduced manufacturing cost compared with board-level integration (PCB).

This increased capacity per unit area can be used to decrease cost and increase functionality.

In electronics, an integrated circuit (also known as IC chip, or microchip) is a miniaturized electronic circuit (consisting mainly of semiconductor devices, as well as passive components) that has been manufactured on the surface of a thin substrate of semiconductor material. Integrated circuits are used in almost all electronic equipment in use today and have revolutionized the world of electronics.

The integrated circuit was invented by Jack Kilby and Robert Noyce. This invention is a boon for digital technologies like computer, mobile phones, MP3 and DVD's. This list could be almost infinite.

Digital electronics :

In the modern electronic world, signal processing plays vital role. Different types of signals with different shapes are generated by different devices. Two shapes of signals or waves are considered here.

Analog signal and Digital signal :

The voltage signals which vary continuously with time are called continuous or analog voltage

signals. The Fig (a) below shows a typical voltage signal, varying as a sinusoidal wave of 0 to 5 v.

In general, symmetrical square wave forms a digital signal. Fig (b) below shows a digital voltage signal, which does not vary continually with time. The values will be equal to 0V or 5V. By representing these two voltage levels as a binary numbers, 0 and 1 can be formed.

Digital signal processing is familiar and formed a digital world. The counters, computers, etc are outcome of digital electronics.

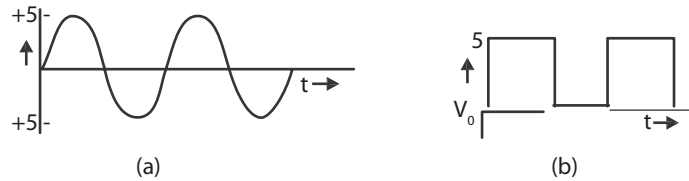

Positive and Negative Logic:

In computing system, the binary number symbols “0” and “1” represent two possible states of a circuit or an electronic device.

In positive logic, the “1” represents

1. an “ON” circuit
2. a “CLOSED” switch
3. a “HIGH” voltage
4. a ”PLUS” sign
5. a ”TRUE” statement.

Consequently, the “0” represents

1. an “OFF” circuit
2. an “OPEN” switch
3. a “LOW” voltage
- 4 a “MINUS” sign
5. a “FALSE” statement.

In Negative logic, just opposite conditions prevail.

Suppose, a digital system has two voltage levels like 0V and 5V.

If we say that value 1 stands for 5V and value 0 for 0V, then we have positive logic system.

If on the other hand, we decide that “1” should represent 0V (low voltage) and 0 should represent 5V (high voltage), then we have negative logic system.

Logic gates :

The logic gates are building blocks of digital electronics. They are used in digital electronics to change one voltage level (input voltage) into another (output voltage) according to some logical statement relating them.

Thus, logic gate is a digital circuit, which works according to some logical relationship between input and output voltage.

The logic gate may have one or more inputs, but only one output.

Truth table of a logic gate is a table that shows all possible input combinations and the corresponding output for the logic gate.

The logical statements that logic gates follow are called “Boolean expressions”.

1. In Boolean algebra, the addition sign (+) is referred as OR. The Boolean expression is

$$y = A + B$$

This Boolean expression is read as y is equal to A 'OR' B.

2. The multiplication sign (.) is referred as AND in Boolean algebra. The Boolean expression is

$$y = A.B$$

This Boolean expression is read as y is equal to A 'AND' B.

3. The bar sign (-) is referred to as NOT in Boolean algebra. The Boolean expression is

$$y = \overline{A}$$

This expression is read as y is equal to 'NOT' A.

BASIC LOGIC GATES:

The following three gates viz., OR gate, AND gate and NOT gate are called as basic logic gates.

OR-GATE

In general, the simple OR gate is a two input and one output logic gate. It combines the inputs A and B to give the output y, following the Boolean expression $y = A + B$. The symbol, truth table and equivalent electrical circuit are shown below.

The function of the OR gate is, the output is "TRUE" if any one of its inputs is in 'TRUE' condition.

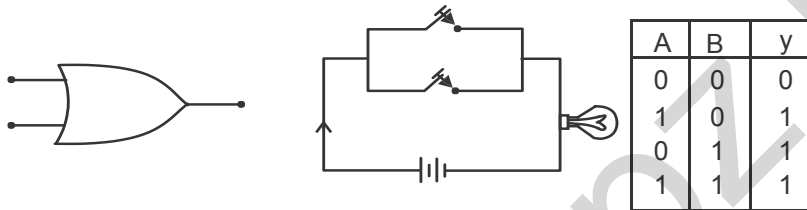

Two parallel Switches and Lamp is connected as shown above.

Lamp "ON" is equal to 1

Lamp "OFF" is equal to 0.

Case 1 :-

If both the Switches A and B are open. No current flow through the external wire. So Lamp is "OFF" i.e. equal to "0".

Case 2 :-

If the Switch A is closed and B is open. The conventional current pass through "A" Lamp is "ON" i.e.. equal to 1

$$1 + 0 = 1$$

Case 3 :-

If Switch A is open and Switch B is closed. Current pass through "B", So Lamp is "ON" i.e.. equal to 1.

$$0 + 1 = 1$$

Case 4 :-

If both the Switches are closed, Lamp is "ON", i.e. equal to 1.

$$1 + 1 = 1$$

So, for all possible input and the obtained output values are tabulated. It is called truth table.

AND gate :-

In general, the simple AND gate is also a two inputs and one output logic gate. It combines the inputs A and B to give the output Y, following the Boolean expression

$$y = A.B$$

i.e. y is equal to A "AND" B. The symbol, equivalent circuit and truth table are shown below.

The function of the AND gate is, the output is 'TRUE' if and only if all the inputs are in 'TRUE' condition.

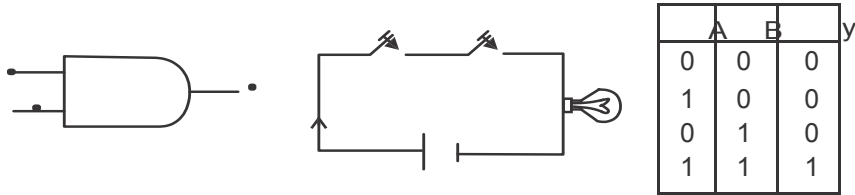

In the above equivalent diagram the switches and the lamp is in series connection mode.

Case 1 :-

If both the switches A and B are OPEN (i.e., A = 0, B = 0) then the lamp will not glow (i.e. y = 0). The current will not pass through the lamp.

Case 2 :-

If the switch “A” is closed and “B” is open, current will not pass through the lamp. The lamp is OFF, so y = 0.

Case 3 :-

If the switch “B” is closed and “A” is open, current will not pass through the lamp. The lamp is OFF, so y = 0.

Case 4 :-

If both switches A and B are closed, current will pass through the circuit. Now the lamp is “ON” and glowing. So y = 1.

NOT gate:-

The NOT gate is a one input and one output logic gate. It inverts or complements the input A to give output y following the Boolean expression.

$$y = \overline{A}$$

This gate is also called as 'inverter'. The symbol, equivalent circuit and truth table are shown below. The equivalent diagram is shown below.

The function of the NOT gate is to invert or complement its input. i.e., the output is 'ON' if input is 'OFF' and vice versa.

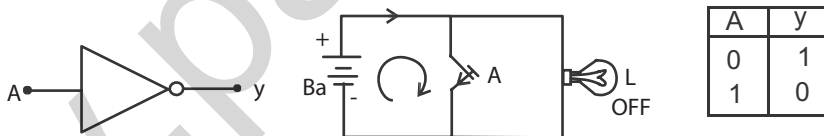

Case 1:-

If the switch “A” is open, the current will pass through the lamp and lamp glows.

So, y = 1 when A = 0

Case 2:-

If the switch “A” is closed, the current will take shortest path. That is current will pass through the switch above. Hence the lamp is “OFF”, so y = 0 when A = 1.

UNIVERSAL LOGIC GATES:

Any logic gate can be made from combinations of NAND gate or NOR gates. Hence, the NOR gate and NAND gate are called as Universal logic gates.

NOR gate

It is a logic gate in which OR gate is followed by a NOT gate. The symbol, equivalent circuit and truth table are shown below.

The function of this gate is 'inverting' the output of the OR gate.

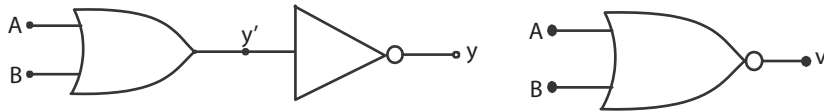

It combines the inputs A and B to give the output y, by the following Boolean expression

$$y = \overline{A + B}$$

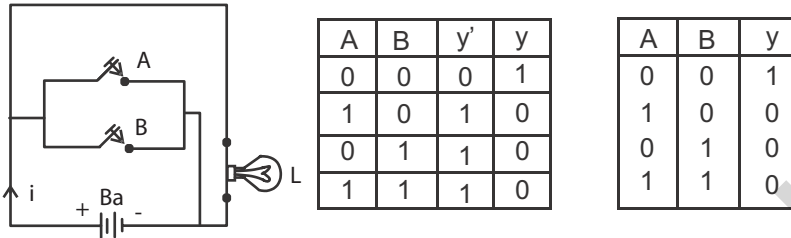

Case 1 :-

If both the switches A and B are open, the current flow through the lamp, Lamp is "ON". So $y = 1$.

Case 2 :-

If the switch A is closed and B is open, the current will pass through the shortest path or low resistance path. Hence conventional current flow through the switch "A" and reaches the cathode of the battery. The lamp is "OFF", so $y = 0$.

Case 3 :-

If the switch A is open and B is closed, the conventional current will pass through the shortest path. The current will pass through the switch B and reaches the cathode of the battery. Current will not pass through the lamp, so lamp is OFF, i.e. $y=0$.

Case 4 :-

If the switch A and B are closed, the current from the battery will pass through two parallel switches and reach the cathode of the battery. Current will flow through shortest path (or) low resistance path. The lamp is "OFF", so $y = 0$.

NAND gate :-

It is logic gate in which AND gate is followed by NOT gate. The symbol, equivalent circuit and truth table are shown below.

The function of this gate is "inverting" the output of the AND gate.

It combines the inputs A and B to give the output y, by the following Boolean expression

$$y = \overline{A \cdot B}$$

$$y = \overline{A \cdot B}$$

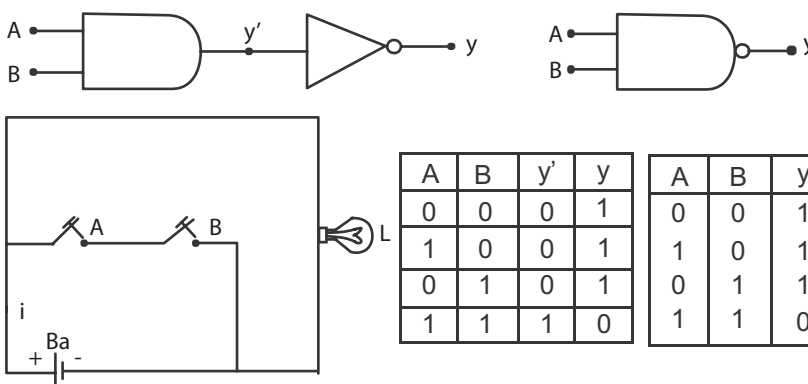

Case 1:-

If both switches A and B are open, the current will flow through the lamp. The lamp is ON, so $y = 1$

Case 2:-

If the switch A is closed and B is open, the current will again flow through the lamp. The lamp is ON, so $y = 1$.

Case 3:-

If the switch A is open and B is closed, the current flows through the lamp. The open switch A act as an inter circuit breaker. The lamp is ON, so $y = 1$.

Case 4:-

If the switch A and B are also in closed position, the current will pass through the switches and reach the cathode of the battery. Current will flow through shortest path (or) low resistance path. Hence, the lamp is OFF, So, $y = 0$

Integrated Circuits :-

An Integrated Circuit (IC) is just a compact electronic circuit. It has both active and passive components.

A discrete circuit is one that is built by connecting separate components. In this case, each component is produced separately and then all are assembled together to make the electronic circuit. For example, consider house wiring. In that, basically switches, lamp and wires are used. They are different components made by different manufactures. We assemble them to form a circuit to energise the lamp and other equipments.

In IC, all components are manufactured on the same silicon wafer. Diodes, transistors, resistors, capacitors and their inter connection is also established well to perform a specific task. Hence all active and passive components are formed on the same chip, using microelectronic techniques.

Scale of Integration :-

In scale of integration, the circuit density and component density is playing important role. For example, 1 lakh components can form 100 circuits. Another circuit designer can form 1000 circuits using the same 1 lakh components. Hence comparing, circuit density and component density is not unique. It all depends upon the application and circuit designer's idea.

An approximate method of classifying the amount of circuit or components density is as follows:-

1. SSI – Small Scale Integration :

In this case, the number of circuits packed in one IC is less than 12 (or) number of components is less than 50.

2. MSI – Medium Scale Integration :

Here, number of circuits per package is between 13 and 99 or number of components is between 50 and 500.

3. LSI – Large Scale Integration :-

In this case, circuit density is between 100 and 9999 or components density is between 5000 and 100 000 (hundred thousand).

4. VLSI – Very Large Scale Integration :-

Here the number of circuits per package is between 10,000 to 99,999 or number of components is between 100 000 and 1 000 000.

In Summary;

Circuits per Chip

SSI	< 12
MSI	12-99
LSI	100 – 9 999
VLSI	10 000 – 99 999

Advantage of ICs:-

ICs have the following advantages:-

1. Extremely small physical size. Often the size is thousands of times smaller than discrete circuit.
2. Weightless when compared with a discrete circuit. Since many circuit functions can be packed into a small area, in many applications where weight and space are critical, such as in air craft, space shuttle, satellite, etc., the IC invention and application brought a very big change in the satellite communication and satellite launching.
3. Life time of ICs is long which is most important from both military and consumer application point of view. Most significant factor is the absence of soldered connections. Extremely high reliability. IC damages are less under proper usage.
4. In signal processing, the signal transfer from one circuit to another circuit or from one device to another device is fast when we use ICs. Moreover, because of short distance between the internal circuits, the stray signal pick is less and nil in many ICs. Response time and speed are more, on the other hand.
5. Low power consumption.
6. Easy replacement
7. Cost effective due to mass production of IC and less failure rate in mass production.

QUESTIONS

Part – A and Part – B

1. What is forbidden energy gap?
2. What is Fermi level?
3. What is Doping?
4. What is the purpose of doping?
5. Name the two types of extrinsic semiconductor and write the majority and minority carriers in each.
6. What is a hole in P type semi conductors?

7. What is potential barrier in P-N Junction diodes?
8. What is depletion region in P-N junction diodes?
9. How will you connect the battery for forward bias? For this bias, does the diode act as a conductor or non conductor?.
10. How will you connect the battery for reverse bias? For this bias, does the diode act as conductor or nonconductor?
11. Draw the symbol for PNP and NPN transistor.
12. Write the three different configurations for a transistor use in electronic circuits.
13. Write any two advantage of common emitter configuration.
14. What is amplification?
15. What is the difference between analog and digital waves?
16. What is positive logic?
17. What is negative logic?
18. What are the basic logicgates?
19. Draw the symbol for OR gate and write the Boolean Expression for the same.
20. Draw the symbol for AND gate and write the Boolean Expression for the same
21. Draw the symbol for NOT gate and write the Boolean Expression for the same
22. What are the universal logic gates?
23. Draw the symbol for NAND gate and write the Boolean Expression for the same
24. Draw the symbol for NOR gate and write the Boolean Expression for the same
25. What is an Integrated Circuit?
26. Scaling of ICs are based on what factors?
27. Give any three advantages of ICs.

Part – C

1. Explain how to identify good conductors, semiconductors and insulators with energy band diagram.
2. Write short notes about in trinsic semi conductor.
3. Explain the Formation of Extrinsic P-type semi conductors.
4. Explain the Formation of Extrinsic N-type semi conductors.
5. Explain the P-N junction diode formation, depletion region and barrier potential.
6. Explain the forward biasaction in a P-N junction diode, with a neat diagram.
7. Explain the reverse bias action in a P-N junction diode, with a neat diagram.
8. Explain the full wave rectifier with a neat circuit diagram and input and output wave forms.
9. Explain the working of a transistor connected in common emitter configuration, asan amplifier.
10. Explain all the three basic logic gates with symbols, Boolean expressions and Truth tables.
11. Explain the NAND and NOR gates with symbols, Boolean expressions and truth tables.
12. Explain level of integration in ICs based on circuit densities and component densities.
13. Discuss the advantages of ICs.

Brain teasers:

1. Analyze the circuit given below and explain the current flow direction through the circuit. When will the lamp glow connected in series with the capacitor?

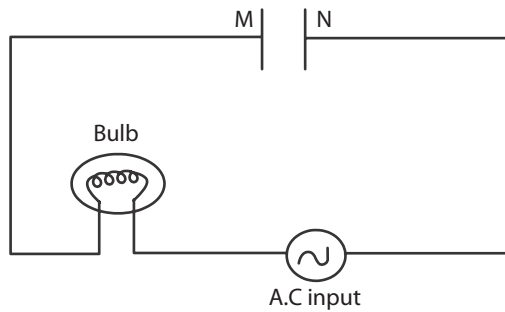

2. In the following circuits, which of the diodes is forward-biased and which is reversed biased?

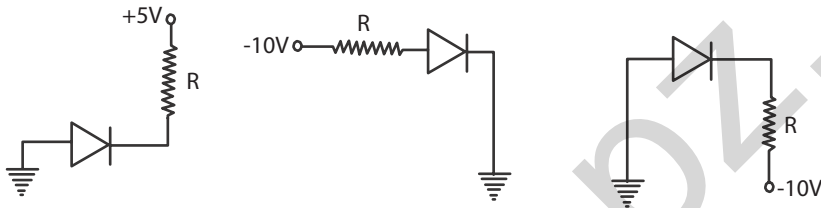

3. How the P.N.P transistor shown below is biased?

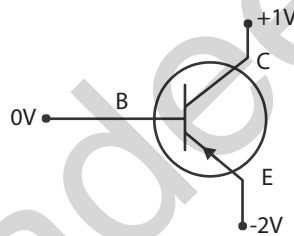

4. Prove that the following diagram's truth table is equal to NAND gate truth table.

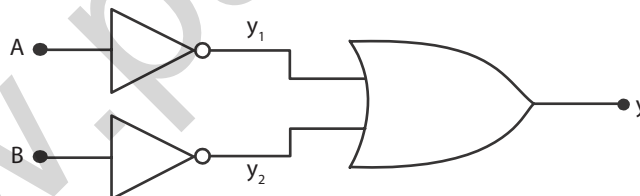

SECOND SEMESTER

PRACTICAL -II

REFRACTIVE INDEX

Experiment No. :**Date :****Aim :**

To determine the refractive index of a transparent liquid (water) using travelling microscope.

Apparatus required :

Given liquid, glass beaker, travelling microscope, lycopodium powder, pin, etc.

Formula :

The refractive index of liquid (water)

$$\mu = \frac{\text{Real depth of the liquid}}{\text{Apparent depth of the liquid}}$$
$$= \frac{\text{Reading 3} - \text{Reading 1}}{\text{Reading 3} - \text{Reading 2}}$$

Description :

A travelling microscope is an ordinary microscope fixed on a stand in such a way that it may be made to travel in vertical as well as horizontal direction without disturbing its adjusted focus. The readings are recorded by means of main scale and vernier scale of high accuracy (0.001 cm) attached to the instrument.

Procedure :

The least count of the microscope is determined as in the case of vernier calipers.

A small pin is fixed horizontally with wax or cello tape at the bottom of the empty beaker. The tip of pin is focussed clearly on the microscope and the corresponding main scale reading (MSR) and vernier scale coincidence (VSC) in the vertical scale are noted in the tabular column. (Reading 1)

The given liquid is taken in the beaker. Now the pin is apparently raised through a height. Therefore, it will be no longer in focus. The microscope is moved up without changing the adjusted focus, so that the image of the pin is clearly seen through the microscope. The corresponding main scale reading (MSR) and vernier scale coincidence (VSC) in the vertical scale are noted in the tabular column. (Reading 2)

Finally, a little lycopodium powder or saw dust which can float on liquid is scattered on the surface of the liquid. The microscope is further moved up without changing the adjusted focus, so that the clear image of lycopodium powder is seen through the microscope. The corresponding main scale reading (MSR) and vernier scale coincidence (VSC) in the vertical scale are noted in the tabular column. (Reading 3)

The difference between this Reading 3 and Reading 1 gives the real depth of the liquid, whereas the difference between Reading 3 and Reading 2 gives the apparent depth of the liquid.

By substituting the readings in the formula, the refractive index of the liquid (water) is determined.

Padeepz App

Result :

The refractive index of the liquid (water) =

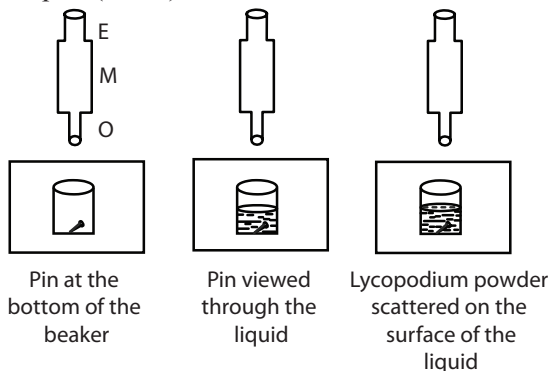

To find Least count of microscope :

$$\begin{aligned}
 \text{Least count:} & \quad \text{Value of 20 MSD} & = & \quad \text{cm} \\
 & \quad \text{Value of 1 MSD} & = & \quad \text{cm} \\
 \text{No. of divisions on the vernier scale(n)} & & = & \\
 & & = & \\
 \text{Least Count (LC)} & = & \frac{1}{n} \times \text{value of 1 MSD} \\
 & = & \text{cm}
 \end{aligned}$$

Tabular column:

Least count = cm

Position	Microscope Readings			
	MSR	VSC	VSR = VSC × LC	OR = MSR + VSR
Unit	cm	div	cm	cm
Clear image of tip of the pin fixed at the bottom of the beaker.				(Reading 1)
Clear image of tip of the pin, after the liquid is taken in the beaker.				(Reading 2)
Clear image of lycopodium powder scattered on the surface of liquid.				(Reading 3)

Calculation:

The refractive index of liquid (water)

$$\mu = \frac{\text{Real depth of the liquid}}{\text{Apparent depth of the liquid}}$$

$$\begin{aligned}
 \text{Real depth of the Liquid} & = \text{Reading 3} - \text{Reading 1} \\
 & = \text{cm} - \text{cm} \\
 & = \text{cm}
 \end{aligned}$$

$$\begin{aligned}
 \text{Apparent depth of the liquid} & = \text{Reading 3} - \text{Reading 2} \\
 & = \text{cm} - \text{cm} \\
 & = \text{cm}
 \end{aligned}$$

$$\text{Refractive index of the liquid } \mu =$$

SOLAR CELL

Experiment No. :

Date :

Aim :

To draw the V-I characteristics curve for the given solar cell.

Apparatus required:

Solar cell, milliammeter (0 – 100 mA), voltmeter (0 – 2 V), variable resistor (0 – 1 k Ω), 60 W bulb, connecting wires, plug key.

Theory :

The solar cell is a semiconductor device that converts solar energy (electromagnetic radiation) into electrical energy by photovoltaic effect. Solar cells are widely used to produce electrical energy from sun's radiation.

A solar cell consists of a p-n junction diode, in which electrons and holes are generated by the incident photons (i.e. electromagnetic radiation). When an external circuit is connected through the p-n junction device, a current passes through the circuit. Therefore, the device generates power when the electromagnetic radiation is incident on it.

Procedure :

A voltmeter, milliammeter and a variable resistor of 0 to 1000 ohm and a plug key are connected as shown in the circuit diagram.

The solar cell is illuminated by a filament bulb of 60 W. Now the two pins of the solar cell are plugged in to the two terminals (A and A) of the milliammeter and the short circuit current I_{sc} is noted, keeping the plug key in open condition.

Then the two pins of the solar cell are plugged into the two terminals (V and V) of the voltmeter and the open circuit voltage V_{oc} is noted, keeping the plug key in open condition.

Now the plug key is closed to include the variable resistor in the circuit. By slowly changing the value of resistance included in the circuit, the milliammeter readings are noted for various values of voltmeter readings in steps of 0.1 V or 0.2 V.

The readings of both the milliammeter and voltmeter are entered in the tabular column. With these readings, the V – I characteristics graph of the solar cell is drawn.

Result :

Thus the V-I characteristics of the solar cell is drawn.

Note:

- i) The V_{oc} and I_{sc} values depend on the type of solar cell and number of solar cells used in the solar panel.
- ii) These values also depend on the source of electromagnetic radiation, which we use to irradiate the solar cell.
- iii) Care should be taken so that the bulb and solar cell do not come into direct contact. (I.e. touch each other). In such case the readings of the meters may go beyond the range and the solar cell may get damaged.

Circuit Diagram

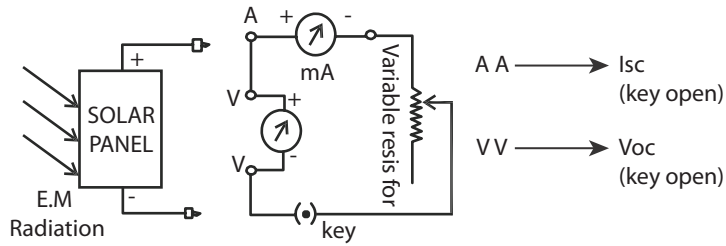

Tabular Column:

Short circuit current I_{sc} = mA

Open circuit voltage V_{oc} = volt

S.No	Voltage generated by the solar cell (V)	Current delivered by the solar cell (I)
Unit	volt	milliampere

Model Graph:

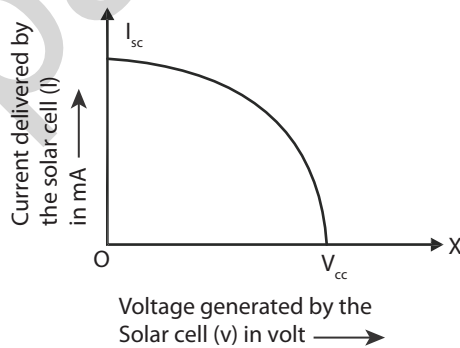

SPECTROMETER**Experiment No. :****Date :****Aim:**

To determine the angle of the prism and the angle of minimum deviation using spectrometer and to calculate the refractive index of glass.

Apparatus required :

Spectrometer, given glass prism, Sodium vapour lamp, Reading lens, black cloth, etc.

Formula:

The refractive index of the material of the glass prism

Where A = angle of the prism

D = angle of minimum deviation

Description :

$$\mu = \frac{\sin \left[\frac{A + D}{2} \right]}{\sin \left[\frac{A}{2} \right]}$$

Spectrometer is an optical instrument having three parts

(i) Collimator (ii) Telescope and (iii) Prism table. The following initial adjustments should be carried out before starting any experiment with a spectrometer.

- The telescope is turned towards a white wall of background and the eyepiece is gently pushed in or pulled out so that a clear image of the cross wires is seen without parallax.
- To adjust the telescope for parallel rays, the telescope is directed towards a distant object like distant tree or building and the distance between the objective lens and the eyepiece is altered till the clear image of the distant object is seen in the field of view of telescope.
- To adjust the collimator for parallel rays, the slit of the collimator is illuminated with a monochromatic source of light (sodium vapour lamp). The telescope is brought in line with the collimator in order to catch the image of the slit in the telescope. The distance between the convex lens in the collimator and the slit is altered to get the clear image of the slit through the telescope, so that the width of the slit is minimized.
- The prism table is made perfectly horizontal by adjusting the screws provided with the help of the spirit level.

Procedure :**Angle of the prism A :**

After making initial adjustments, the least count of the spectrometer is determined (as in Vernier Calipers).

Having a very fine slit, the telescope is adjusted for direct ray. A prism is placed on the prism table as shown in the figure. The telescope is turned to catch the reflected image from one polished face AB of the prism. Fixing in that position, the tangential screw is adjusted till the vertical cross wire is made to coincide with the fixed edge of the image of the slit. The readings in the scales I and II are noted.

Padeepz App

The telescope is then turned to the other polished face AC of the prism. The readings in the scales I and II are noted when the vertical cross wire coincides with the fixed edge of the image of the slit. The difference between both the scale I readings is $2A$. Similarly the difference between both the scale II readings is $2A$. Then the average of the angle of the prism A is calculated.

Angle of minimum deviation D :

The prism is placed on the prism table as shown in the figure. The ray of light from the collimator incident on one polished face of the prism gets refracted and emerges out of the other polished face. Viewing the image of the slit through the telescope, the prism table and telescope are rotated simultaneously through small angle such that the image of the slit moves towards the direct ray. At one stage, it is found that the image of the slit is stationary for a moment and on rotating the prism table further in the same direction the image begins to retrace its path. The telescope is fixed at that position, the cross wire is made to coincide with the fixed edge of the image of the slit. At this minimum deviation position, the readings of scales I and II are noted.

The prism is removed from the prism table. The telescope is brought in line with the collimator and the image of the slit is seen through the telescope. The vertical cross wire is made to coincide with the fixed edge of the image of the slit. The readings in the scales I and II are noted.

The difference between the two readings of scale I or scale II gives the angle of minimum deviation D . Hence the refractive index of the material of the prism is calculated using the formula.

Result :

The refractive index of the material of the prism $\mu =$

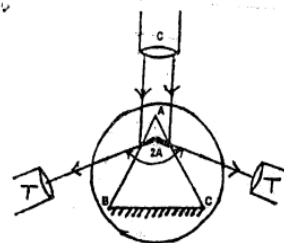
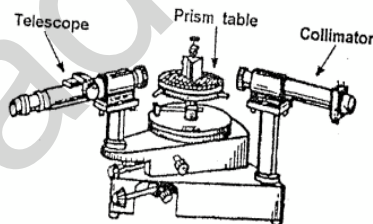

Observations :

Least count of Spectrometer :

Value of 20 MSD =

Value of 1 MSD =

No. divisions on the Vernier scale (n) =

Least Count (LC) = $\frac{1}{n} \times \text{value of 1MSD}$

Tabular column I :

To determine the angle of the prism A

LC =

Ray	Spectrometer readings in degree							
	Scale I				Scale II			
	MSR	VSC	VSR = VSC × LC	OR = MSR + SR	MSR	VSC	VSR = VSC × LC	OR = MSR + VSR
Reading of the reflected ray (left)				$x_1 =$				$x_3 =$
Reading of the reflected ray(right)				$x_2 =$				$x_4 =$

$$2A = (x_1 \sim x_2)$$

$$A = \frac{\quad}{2} =$$

$$2A = (x_3 \sim x_4) =$$

$$A = \frac{\quad}{2} =$$

The average angle of the prism A = $\frac{\quad + \quad}{2} =$

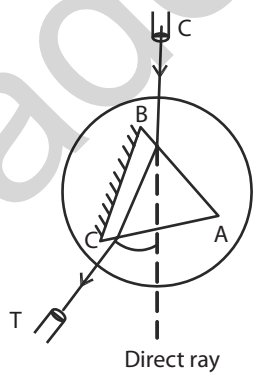

Tabular column II:

To determine the angle of the minimum deviation D LC =

Ray	Spectrometer readings in degree							
	Scale I				Scale II			
	MSR	VSC	VSR = VSC × LC	OR = MSR + SR	MSR	VSC	VSR = VSC × LC	OR = MSR + VSR
Reading of minimum deviated ray				$d_1 =$				$d_3 =$
Reading of Direct ray				$d_2 =$				$d_4 =$

The angle of the minimum deviation of the prism $D = \frac{D_1 + D_2}{2}$
 $D_1 = (d_1 \sim d_2) =$ $D_2 = (d_3 \sim d_4) =$
 $=$

Calculation:

$$\mu = \frac{\sin \left[\frac{A + D}{2} \right]}{\sin \left[\frac{A}{2} \right]} = \quad =$$

The refractive index of the material of the glass prism

OHM'S LAW

Verification of Laws of Resistances

Experiment No. :

Date :

Aim :

To verify the laws of resistances when the two given standard resistances are connected i) in series and ii) in parallel, using Ohm's law.

Apparatus required :

Two known standard resistances, battery, key, rheostat, ammeter, voltmeter, connecting wires, etc.

Formulae:

i) When two resistances R_1 & R_2 are connected in series, their effective resistance is given by the formula $R_s = R_1 + R_2$

$$R_s = \frac{E}{I} \quad \text{⚡}$$

The formula for determining the effective resistance by experiment is

ii) When two resistances R_1 & R_2 are connected in parallel, their effective resistance is given by the formula

$$R_p = \frac{R_1 \times R_2}{R_1 + R_2} \quad \text{⚡}$$

The formula for determining the effective resistance by experiment is

$$R_p = \frac{E}{I} \quad \text{⚡}$$

where

R_1 = the value of the one standard resistance (⚡)

R_2 = the value of the other standard resistance (⚡)

E = Potential difference between the ends of the resistances (V)
(Voltmeter reading)

I = Current flowing through the resistances (Ammeter reading) (A)

Procedure:

Resistances in series:

The given two resistances R_1 and R_2 are connected in series. This combination is again connected in series with a battery eliminator, key, rheostat and an ammeter. The voltmeter is connected in parallel to the combination of resistances to measure the potential difference across the resistances.

Now the circuit is closed. By adjusting the rheostat for different values of current, the corresponding values of potential difference are noted in tabular column I. The effective resistance R_s is calculated in each case using the formula. Then the average value of effective resistance R_s is calculated.

Resistances in parallel :

The given two resistances R_1 and R_2 are connected in parallel. This combination is again connected in series with a battery eliminator, key, rheostat and an ammeter. The voltmeter is connected in parallel to the combination of resistances, to measure the potential difference across the resistances.

Now the circuit is closed. By adjusting the rheostat for different values of current, the corresponding values of potential difference are noted in tabular column II. The equivalent resistance R_p is calculated in each case using the formula. Then the average value of effective resistance R_p is calculated.

Result :

- 1) When the resistances are connected in series:
 - i. The effective resistance by calculation $R_s =$ ohm
 - ii. The effective resistance by experiment $R_s =$ ohm
- 2) When the resistances are connected in parallel :
 - i. The effective resistance by calculation $R_p =$ ohm
 - ii. The effective resistance by experiment $R_p =$ ohm

The laws of resistances are verified, using Ohm's law.

Circuit diagram for series connection

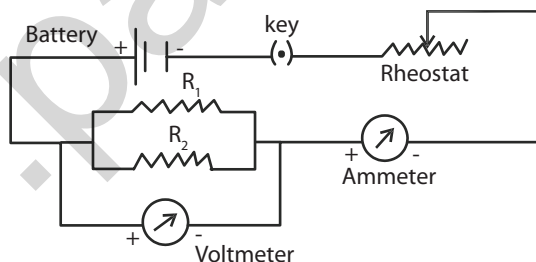

Resistance $R_1 =$	ohm;	Resistance $R_2 =$	ohm
Effective resistance $R_s = R_1 + R_2$			
=	ohm	=	ohm

Tabular column I:

To find the value of effective resistance when R_1 and R_2 are in series

Sl. No	Current flowing through the resistances (Ammeter reading)		Potential difference between the ends of resistances (Voltmeter reading)		$R_s = \frac{E}{I}$
	I		E		
Unit	div	ampere	div	volt	ohm
1.					
2.					
3.					
4.					
5.					

Average value of effective resistance when R_1 and R_2 are connected in series R_s } = ohm

Calculation:

1) $E =$ volt ; $I =$ ampere; $R_s = \frac{E}{I}$

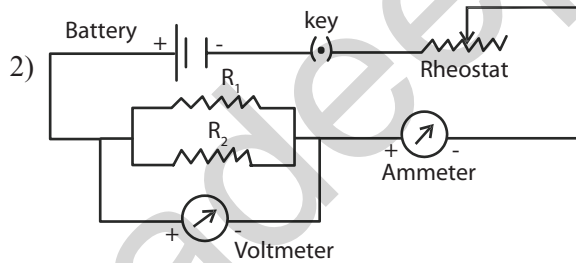

Circuit diagram for parallel connection

Resistance $R_1 =$ ohm; Resistance $R_2 =$ ohm

Effective resistance $R_p = \frac{R_1 \times R_2}{R_1 + R_2} =$
 $=$ ohm

Tabular column II :

Sl. No	Current flowing through the resistances (Ammeter reading)		Potential difference between the ends of resistances (Voltmeter reading)		$R_p = \frac{E}{I}$
	I		E		
Unit	div	ampere	div	volt	ohm
1.					
2.					
3.					
4.					
5.					

Average value of effective resistance when R_1 and R_2 are connected in series R_s } = ohm

Calculation:

$$1) E = \quad \text{volt}; \quad I = \quad \text{ampere}; \quad R_s = \frac{E}{I}$$

2)

JOULE'S CALORIMETER**Experiment No.****Date:****Aim:**

To determine the specific heat capacity of water (liquid), using Joule's calorimeter.

Apparatus required :

Joule's calorimeter, battery eliminator, ammeter, voltmeter, rheostat, plug key, stop watch, thermometer, digital balance, liquid (water), connecting wires, etc.

Formula :

$$S = \frac{EIt}{(m_2 - m_1)(T_2 - T_1)} - \frac{m_1 S_c}{(m_2 - m_1)} \quad \text{J kg}^{-1} \text{K}^{-1}$$

The specific heat capacity of the liquid

where

E = potential difference across the heating coil (Voltmeter reading)(V)

I = current flowing through the heating coil (Ammeter reading)(A)

t = time for which the current flows to increase the temperature of water (S)

m_1 = mass of empty and dry calorimeter with stirrer (kg)

m_2 = mass of calorimeter with stirrer and water (kg)

S_c = specific heat capacity of the material of the calorimeter ($\text{J kg}^{-1} \text{K}^{-1}$)

T_1 = initial temperature of the liquid and (K)

T_2 = final temperature of the liquid (K)

Description :

The Joule's calorimeter consists of a brightly polished copper or aluminium vessel closed by an ebonite lid with two holes. A heating coil, connected to two binding screws provided on the ebonite lid is kept within the calorimeter. Through holes in the lid a sensitive thermometer and a stirrer can be inserted. The calorimeter is placed inside a wooden box stuffed with cotton or wool.

Procedure :

The mass of the clean, dry calorimeter with stirrer (m_1) is determined using a digital balance. The calorimeter is filled to two- third of its volume with the given liquid (water) and the mass (m_2) is once again determined.

The calorimeter is kept in the wooden box and the heating coil is completely immersed in the liquid. Connections are given as shown in the circuit diagram.

The circuit is closed for a moment and the rheostat is adjusted for a suitable current of 0.8 A or 1.0 A. The ammeter and voltmeter readings are noted as I and E respectively. The circuit is kept open. Now, the liquid is stirred well and the initial temperature (T_1) of the liquid is determined using a sensitive thermometer.

The circuit is again closed and simultaneously a stopwatch is started. The liquid is stirred slowly and uniformly. The temperature of the liquid is noted for every minute in the tabular column. When the temperature of the liquid is increased by 5°C , the key is removed and the stopwatch is stopped simultaneously.

The time (t second) for which the current was flowing through the circuit is noted from the stopwatch. The specific heat capacity of the material of the calorimeter (S_c) is taken from tables.

Then, the specific heat capacity of the water (S) is calculated using the given formula.

Result :

The specific heat capacity of water is found to be $S = J \text{ kg}^{-1} \text{ K}^{-1}$

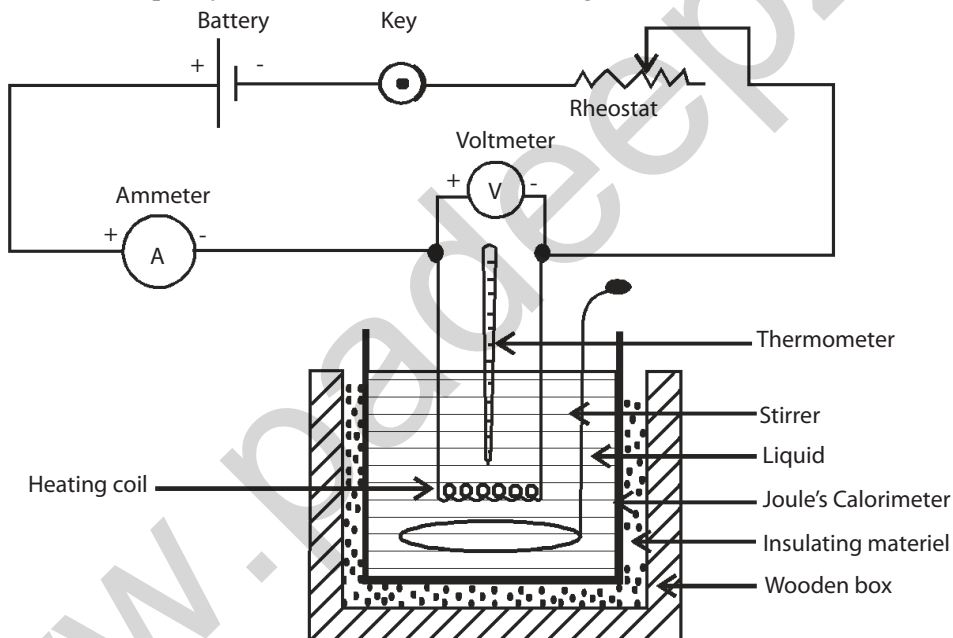

Observation :

Mass of the empty calorimeter with stirrer	(m_1)	=	g
		=	kg
Mass of calorimeter with stirrer + water	(m_2)	=	g
		=	kg
Current flowing through the heating coil (Ammeter reading)	} (I)	=	A
Potential difference across the coil (voltmeter reading)		} (E)	=
Initial temperature of water	(T_1)		=

Final temperature of water	(T_2)	=	$^{\circ}\text{C}$
Time for which current is passed to	(t)	=	minutes
increase the temperature of water		=	second
Specific heat capacity of the	(S_c)	=	$\text{J kg}^{-1} \text{K}^{-1}$
material of the calorimeter (copper) }			

Tabular column :

To record the time taken for 5 C raise in temperature of water

Time in minutes	Temp. of water in $^{\circ}\text{C}$

Time taken for 5 $^{\circ}\text{C}$ raise in temp. of water $(t) =$ s

Calculation :

The specific heat capacity of water

$$S = \frac{Eit}{(m_2 - m_1)(T_2 - T_1)} - \frac{m_1 S_c}{(m_2 - m_1)}$$

$$= \text{J kg}^{-1} \text{K}^{-1}$$

Padeepz App

COPPER VOLTAMETER

Experiment No.:**Date:****Aim:**

To determine the electro chemical equivalent (e.c.e) of copper, using copper voltameter.

Apparatus required :

Copper voltameter, battery eliminator, plug key, rheostat, ammeter, stop watch, digital balance, connecting wires, emery sheet, etc.

Formula :

The electro chemical equivalent of copper

$$Z = \frac{m}{It} = \frac{m_2 - m_1}{It} \quad \text{kg C}^{-1}$$

where

m = mass of copper deposited on the cathode (kg)

m_1 = mass of the cathode before passing current(kg)

m_2 = mass of the cathode after passing current(kg)

I = current flowing through the electrolyte (Ammeter reading)(A)

t = time of passage of current (S)

Description :

The copper voltameter consists of a glass vessel, containing a strong solution of copper sulphate. Three plates of copper are dipped in the solution. The two outer plates are connected together and they form the anode. The middle plate serves as the cathode.

Procedure :

The copper voltameter is connected in series with the battery, plug key, rheostat and ammeter. It should be noted that the negative of the battery is connected to the central cathode plate. After making all the connections, the circuit is closed for a moment and the rheostat is adjusted for a suitable current, say 1 ampere, in the ammeter. The circuit is kept open, the cathode plate is removed and cleaned with emery sheet. It is then washed in water, dried and its mass m_1 is determined accurately using a digital balance.

The cathode plate is then fixed in its position and the circuit is closed, simultaneously starting a stopwatch. The current is passed for 30 minutes and during the passage of current the ammeter value should be maintained as the same.

After 30 minutes the cathode is taken out, rinsed with water, dried and its mass m_2 is found accurately. The time of passage of current is noted. The mass of copper deposited is determined and hence e.c.e. of copper is calculated using the given formula.

Result :

The electro chemical equivalent of copper $Z =$ kg C^{-1}

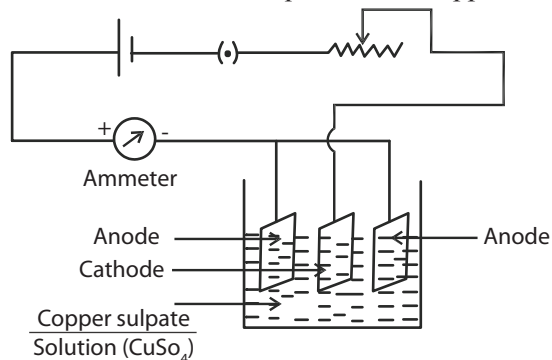

Observation :

Mass of the cathode before passing current m_1	=	g
Mass of the cathode after passing current m_2	=	kg
	=	g
	=	kg
Mass of the copper deposited at cathodem m	=	$(m_2 - m_1)$
	=	kg
Current flowing through the electrolyte (Ammeter reading)	} I	= A
Time of passage of current		t
	=	minutes
	=	second

Recording of time of passage of current (in minutes) :

1	2	3	4	5	6	7	8	9	10	11	12	13	14	15
16	17	18	19	20	21	22	23	24	25	26	27	28	29	30

Calculation :

The electro chemical equivalent of copper

$$Z = \frac{m}{It} = \frac{m_2 - m_1}{It}$$

$$=$$

$$= \text{kg C}^{-1}$$

CHARACTERISTICS OF P-N JUNCTION DIODE

Experiment No. :

Date :

Aim :

To draw the voltage - current characteristics of a P-N Junction diode in forward bias and to find the 'dynamic forward resistance' and 'knee voltage' from the graph

Apparatus required :

P-N junction diode (Germanium or Silicon), D.C. power supply (0 - 10 V), D.C. milliammeter (0 – 15 mA), D.C. Voltmeter (0 – 1.5 V), resistance (500 Ω), etc.

Formula :

$$\text{The dynamic forward resistance } r = \frac{\Delta V}{\Delta i}$$

where

ΔV = a small change in potential difference (p.d) applied to the diode

Δi = the corresponding change in the current flowing through the diode

Knee voltage (V_k): It is the approximate voltage above which the diode current increases sharply.

Theory :

When the positive terminal of the battery is connected to P-type and negative terminal to N-type of a semiconductor diode, current flows easily through the diode. Now it is said to be in forward bias.

When the P-type material is connected to negative and N-type to positive of the battery, the diode offers a high impedance path and little current flows through the diode. Now it is said to be in reverse bias.

This property of P-N Junction diode, allowing the flow of current in one direction easily is made use of in many electronic circuits, especially in solid state half-wave and full-wave rectifiers.

Procedure :

The anode and cathode of a P-N junction diode can be identified by seeing a colour band or spot on the cathode. Also the cathode may be having pointed edge in some type.

For forward biasing, the connections are given neatly as shown in the diagram. Suitable ranges of meters, resistance and power supply can be selected.

The current flowing through the diode is noted for various values of p.d. applied across the diode and the readings are noted in the tabular column. With these readings, a neat graph is drawn by taking forward voltage applied across the diode in X - axis and forward current flowing through the diode (in mA) along Y - axis.

This curve is called as the forward characteristics of the diode. From this graph, the approximate voltage above which the diode current sharply increases, can be determined, which gives the "Knee Voltage" of the diode.

For germanium diode, the knee voltage is 0.3 volt and for silicon diode the knee voltage is 0.7 volt, which is almost equal to the barrier potential.

In the upper region of the curve, two perpendicular lines OA and AB are drawn to find the dynamic forward resistance, as shown in the model graph. In this OA gives the value of small change in p.d. applied across the diode (Δv) and AB gives the corresponding change in the current flowing through the diode (Δi). These values are determined.

Then the dynamic forward resistance of the diode is determined by using the given formula.

Result :

The forward characteristics of a P-N Junction diode is drawn.

From the graph,

(i) The dynamic forward resistance $r =$ ohm

(ii) The knee voltage $V_k =$ volt

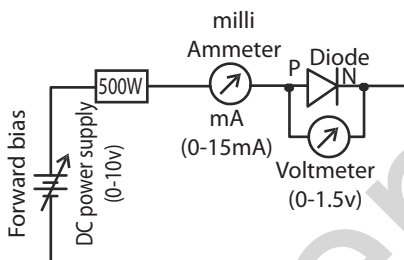

Circuit diagram for drawing the forward characteristics of P-N junction diode.

Tabular column :

Readings for drawing the forward characteristics of P-N junction diode

Sl. No.	P.d applied across the diode (v)		Current flowing through the diode (i)	
	div	volt	div	milliampere (mA)
1.				
2.				
3.				
4.				
5.				
6.				
7.				
8.				
9.				

Calculation :

From graph,

$\Delta V =$ div ; $\Delta i =$ div

For calculating ΔV in volt

In X – axis 10 div = volt ; 1 div = volt

$\therefore \Delta V =$ div = x = volt

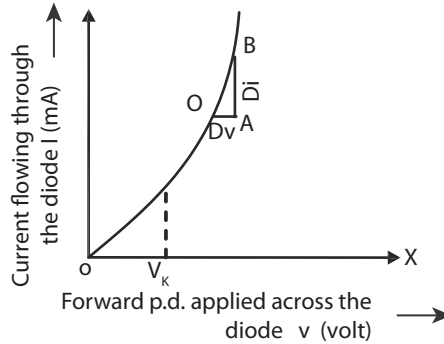

For calculating Δi in mA

$$\begin{aligned} \text{In Y-axis } 10 \text{ div} &= \text{mA} ; 1 \text{ div} = \text{mA} \\ \therefore \Delta i &= \text{div} = x = \text{mA} \\ &= \times 10^{-3} \text{ A} \end{aligned}$$

(i) The dynamic forward resistance is $r = \frac{\Delta V}{\Delta i} \Omega$

$$= \text{ohm}$$

(ii) The knee voltage is $V_k = \text{div}$
 $= x$
 $= \text{volt}$

LOGIC GATES

Experiment No. :

Date :

Aim :

To find the output condition for different combinations of the inputs for NOT gate and two inputs AND, OR, NAND and NOR logic gates, using I C Chips.

Apparatus required :

Logic gate apparatus kit with chip mounting base, integrated circuit chips (IC chips) for the above logic gates.

Description :

The logic gate kit consists of required DC power supply, light emitting diodes (LEDs), to indicate the input and the output signal, toggle switches to provide various combinations of input and breadboard to mount the desired IC chip.

In the kit when the LED glows, the corresponding condition is “ON”,

and the binary is 1. If the LED does not glow the corresponding condition is “OFF”, and the binary is 0.

Procedure :

(a) NOT gate :

It is the simplest form of the logic gates. It has only one input and one output. The function of this gate is to produce one logic level from the opposite logic level. i.e. If the input condition is “ON”, the output condition will be “OFF” and if the input condition is “OFF”, the output condition will be “ON”.

The NOT gate is available in IC chip number 7404. The pin configuration for the power supply, ground, input and output of the IC chip is given in the figure and the Boolean expression is also given.

The 7404 IC is mounted on the base provided in the kit. Suitable input level is given and the corresponding output level is noted in the truth table of NOT gate.

The function of this gate is inverting or complementing the input signal. So, this gate is also called as a 'Complementer or Inverter gate'.

(b) AND gate :

This gate has two or more inputs and only one output. The function of this gate is to produce a true condition on its output, if and only if all its input conditions are true. i.e., the output of the gate is in "ON" condition if and only if all its inputs are in "ON" condition.

The two inputs AND gate is available in IC chip number 7408. The pin configuration for the power supply, ground, input and output of the IC chip is given in the figure and the Boolean expression is also given.

The 7408 IC is mounted on the base provided in the kit. Suitable combinations of input levels are given and the corresponding output levels are noted in the truth table of AND gate.

This gate is also called as a 'Multiplier gate'.

(c) OR gate :

This gate has two or more inputs and only one output. The function of this gate is to produce the true condition on its output, when one or more of its input conditions are true. i.e., The output of the gate is in "ON" condition if any one of its inputs is in "ON" condition.

The two inputs OR gate is available in IC chip number 7432. The pin configuration for the power supply, ground, input and output of the IC chip is given in the figure and the Boolean expression is also given.

The 7432 IC is mounted on the base provided in the kit. Suitable combinations of input levels are given and the corresponding output levels are noted in the truth table of OR gate.

This gate is also called as a 'Adder gate'.

These above three gates are called 'Basic Gates'.

(d) NAND gate :

It is a combination of AND and NOT gates. The output of NAND gate is complementation of that of an AND gate.

The two inputs NAND gate is available in IC chip number 7400. The pin configuration for the power supply, ground, input and output of the IC chip is given in the figure and the Boolean expression is also given.

The 7400 IC is mounted on the base provided in the kit. Suitable combinations of input levels are given and the corresponding output levels are noted in the truth table of NAND gate.

e) NOR gate :

This gate is a combination of NOT and OR gates. The output of the NOR gate is Complementation of that of an OR gate.

The two inputs NOR gate is available in IC chip number 7402. The pin configuration for the power supply, ground, input and output of the IC chip is given in the figure and the Boolean expression is also given.

The 7402 IC is mounted on the base provided in the kit. Suitable combinations of input levels are given and the corresponding output levels are noted in the truth table of NOR gate.

These above two gates are known as 'Universal gates'.

Result :

Thus the output condition for different combinations of the inputs for NOT gate and two inputs AND, OR, NAND and NOR logic gates are noted in the truth table.

a) NOT gate :

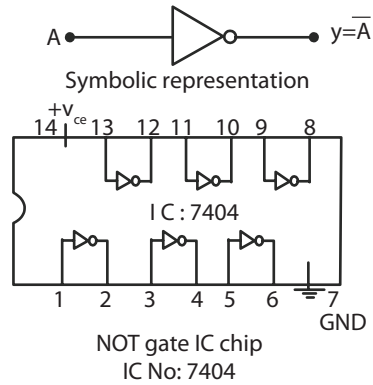

NOT gate IC chip

IC No: 7404

Pin configuration :

- Input pins : 1,3,5,9,11,13
- Output pins : 2,4,6,8,10,12
- Ground pin : 7
- Power pin (+ V_{cc}) : 14

Truth table for NOT gate

INPUT	OUTPUT
A	$Y = \overline{A}$
0	
1	

b) AND gate :

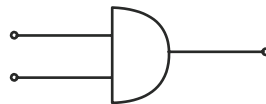

Symbolic representation

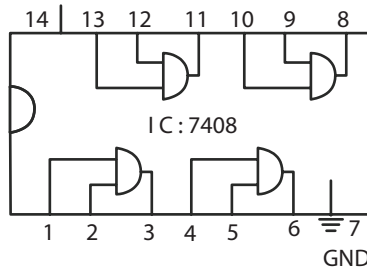

Two input AND gate IC chip

IC No: 7408

Pin configuration:

- Inputpins : 1,2,4,5,9,10,12,13
- Output pins : 3,6,8,11
- Ground pin : 7
- Power pin (+ V_{cc}) : 14

Truth table for AND gate

INPUTS		OUTPUT Y = A.B
A	B	
0	0	
0	1	
1	0	
1	1	

c) OR gate :

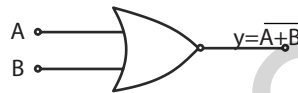

Symbolic representation

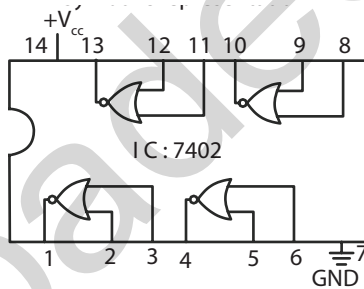

Two input NOR gate IC chip
IC No: 7402

Two input OR gate IC chip

IC No: 7432

Pin configuration:

- Inputpins: 1,2,4,5,9,10,12,13
- Output pins: 3,6,8,11
- Ground pin : 7
- Power pin (+ V_{cc}): 14

Truth table for OR gate

INPUTS		OUTPUT Y = A + B
A	B	
0	0	
0	1	
1	0	
1	1	

d) NAND gate:

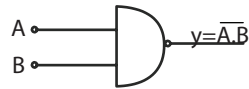

Symbolic representation

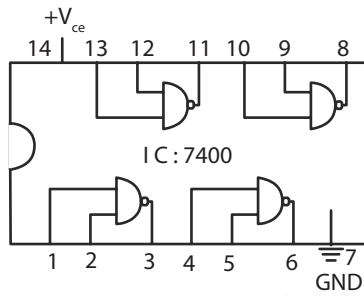

Two input NAND gate IC chip

IC No: 7400

Pin configuration:

Input pins: 1,2,4,5,9,10,12,13

Output pins: 3,6,8,11

Ground pin : 7

Power pin (+ V_{cc}): 14

Truth Table for NAND gate

INPUTS		OUTPUT
A	B	Y = A . B
0	0	
0	1	
1	0	
1	1	

e) NOR gate :



Symbolic representation

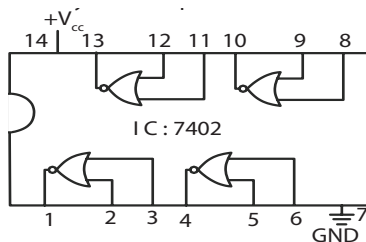

Two input NOR gate IC chip

IC No: 7402

Pin configuration:

Input pins: 2,3,5,6,8,9,11,12

Output pins: 1,4,10,13

Ground pin : 7

Power pin (+ V_{cc}): 14

Truth table for NOR gate

INPUTS		OUTPUT
A	B	$Y = \overline{A+B}$
0	0	
0	1	
1	0	
1	1	

MODEL QUESTION PAPER

1. Determine the refractive index of the given transparent liquid using traveling microscope.
2. Draw the $V - I$ characteristics of the solar cell.
3. Measure the angle of the prism and the angle of minimum deviation using spectrometer and then calculate the refractive index of glass.
4. Verify the laws of resistances by connecting the two given standard resistances (i) in series and (ii) in parallel, using Ohm's law.
5. Determine the specific heat capacity of water, using Joule's calorimeter.
6. Determine the electro chemical equivalent (e.c.e.) of copper using Copper Voltmeter.
7. Draw the voltage – current characteristics of a P-N junction diode in forward bias and then find the 'dynamic forward resistance' & 'knee voltage' from the graph.
8. Find the output conditions for different combinations of the input for NOT gate (7404) and 2 inputs AND, (7408) OR, (7432) NAND (7400) & NOR (7402) logic gates using IC chips.